

150W Power Supply Model: HY-T150



I . Main Features

- 1) **Good compatibility:** It can be applicable to 150W,130W,120W,100W laser tubes
- 2) When input AC220V and output current up to 38mA,The voltage can be up to 25KV.
- 3) **Fast Response speed:**it can enlarge laser power observably and prolong laser tube's service life.
- 4)**Easy Control:** High level or low level all suitable to Control.
- 5)**Open circuit protection Function:** when the earth connection is under good situation,Power can be short time work in open state, it Can avoid the laser tube burst damage caused by laser power supply, prolong the laser tube's service life.
- 6)**One button** to test the output laser manually.
- 7) TTL Signal indication, water though signal indication, and laser output indication.
- 8) **Application:** Sculpture and cut acrylic, fabric,double color sheet ,rubber etc.

II. Specification:

Input	Input Voltage	AC220V or AC110V (to be specified when placing order)	
	AC frequency	47—440HZ	
	Cold Surge Current	≤60A(AC220V Input)	≤30A(AC110 Input)
	Current Leakage	≤0.7MA (AC220V Input)	≤0.4MA(AC110V Input)

150W Power Supply Model: HY-T150

Output	Maximum Input Voltage	DC 50KV
	Maximum Output Current	DC 38MA
Efficiency	≥90 % (full load)	
MeanTime Between Failure (MTBF)	≥10000H	
Response Speed	≤1ms (from the switch Signal is given to the output current up to 90% of the setting current)	
Control Interface	TTL level switch control; high or low effective level can be chosen (details refer to the control terminal specification)	
Withstand Voltage	Input-Output, Input-Shell: AC1500V 10MA 60S; Output negative is connected with machine shell.	
Protection	can work in open-circuit condition for a short time (Require a good protective earthing and avoid arc between the positive and the machine shell)	
Environment	Operating Temperature : -10~40°C), Relative Humidity (RH)≤90 %	
Cooling Way	Force-Air Cooling (FAC)	
Dimension	L×W×H=325*240*97(mm)(normal type)	
Color	Black	

III.Operation Instruction:

1)Laser Tube connection: (Referring to Power supply and laser device's connection diagram- figure

1)High voltage terminal (HV+) of HY-T150 power supply should be connected to the positive pole of CO2 laser device. Current circuit of the power supply shall be connected to negative pole (laser output terminal) of laser device, through an ampere meter or directly.

2)Connection of control signal

The control signal shall be reliably connected to control terminal of the power supply HY-T150, after connecting the DAC output signal and TTL signal of external computer with the power supply, the laser device shall work as expected. If the laser lamp can not work properly, should check the control signal is correct or not(include check the voltage specification and logic),if use PWM control as power control,make sure $f \geq 20\text{KHz}$,Amplitude (peak value) $\leq 5\text{V}$,Check and make sure protection switch WP connection is correct at same time.

3)Voltage of power input:

HY-T150 's power input of the power supply shall be 220VAC/50Hz. If 110VAC is needed, please specify when placing order.

4)Others:

A group of protection switches are also reserved for detection of water switch, fan switch, open-enclosure protection and so on.

Caution:

150W Power Supply Model: HY-T150

1. Water cooling system should be working properly when switching on laser device.
2. Circuit of high voltage output should not be open! (High voltage output terminals (positive and negative poles) shall be properly connected to positive and negative poles of laser device, respectively.)
3. Attentions should be given to avoid any electric shock after the power supply being switched off. (The **Insulation safety requirements** should be 40KV between the terminal of output and "G")
4. Well-grounded three-pole receptacle should be used to supply power to HY-T150 power supply. The enclosure should be well grounded to avoid electric shock.

IV. The size of power supply and terminals)

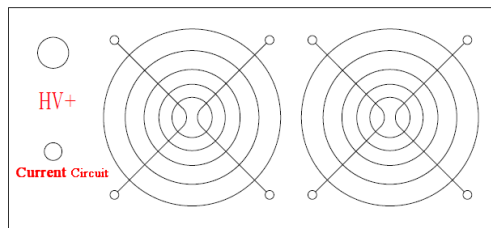
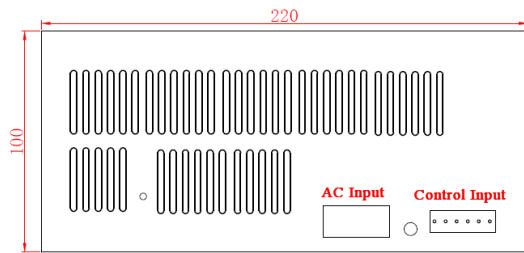

V. The instruction of Power supply & laser wiring diagram & terminal

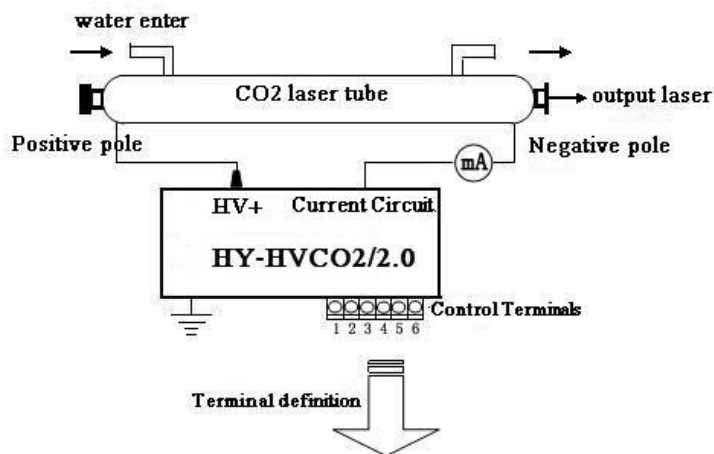

Terminal Definition

1	2	3	4	5	6
TH	TL	WP	G	IN	5V

150W Power Supply Model: HY-T150

The terminal definition as follow :

TH	Input Signal	Switch Light Control, High Level($\geq 3V$)- Bright dipping , Low Level($\leq 0.3V$) - No Light Dipping
TL	Input Signal	Switch Light Control, High Level ($\geq 3V$) - No light Dipping, Low Level ($\leq 0.3V$) -Bright Dipping
WP*1	Input Signal	Switch Light Control, High Level ($\geq 3V$) - No light Dipping, Low Level ($\leq 0.3V$) -Bright Dipping
G	Signal Ground	The foot must connected with laser machine's enclosure , Control Module and ground properly.
IN*2	Input Signal	Laser Power supply control terminal , can use 0—5V Analog Signal Control, ,also can use 5V PWM Signal to Control
5V	Output Power	5V , Max output Current 20mA

Caution :



Figure 1

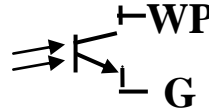

Figure 2

NOTE:

1).WP can be used as detecting end of blower switch or water detection switch. If WP and ground are not connected by empty node like picture 1, but connected through optocoupler, the connection will be like picture 2.

1)WP input terminal can use water switch or fan switch's test terminal, Please pay attention that WP is through optocoupler connected with ground (G) as (figure2) , not as (figure 1). 2)(PWM control): Requirements of the PWM frequency $f \geq 20kHz$, amplitude(peak value) $\leq 5V$

Function of control interface:

TH	TL	WP	IN	Laser Output
unconnected	Low($\leq 0.3V$)	Low($\leq 0.3V$)	0—5V or PWM	Output laser Power: Pmin~Pmax
	Low($\leq 0.3V$)		unconnected	Output about 40% laser
	High($\geq 3V$)		Any value (ok)	No laser
High($\geq 3V$)	Unconnected		0—5 or PWM	Output laser, Pmin~Pmax
High($\geq 3V$)			Unconnected	Output about 40% laser
Low($\leq 0.3V$)			Any value (ok)	No laser
Any value (ok)	Any value (ok)	High($\geq 3V$)		No laser

VI. The connection of power supply and control board

1.Recommended connection: High-level light control

150W Power Supply Model: HY-T150

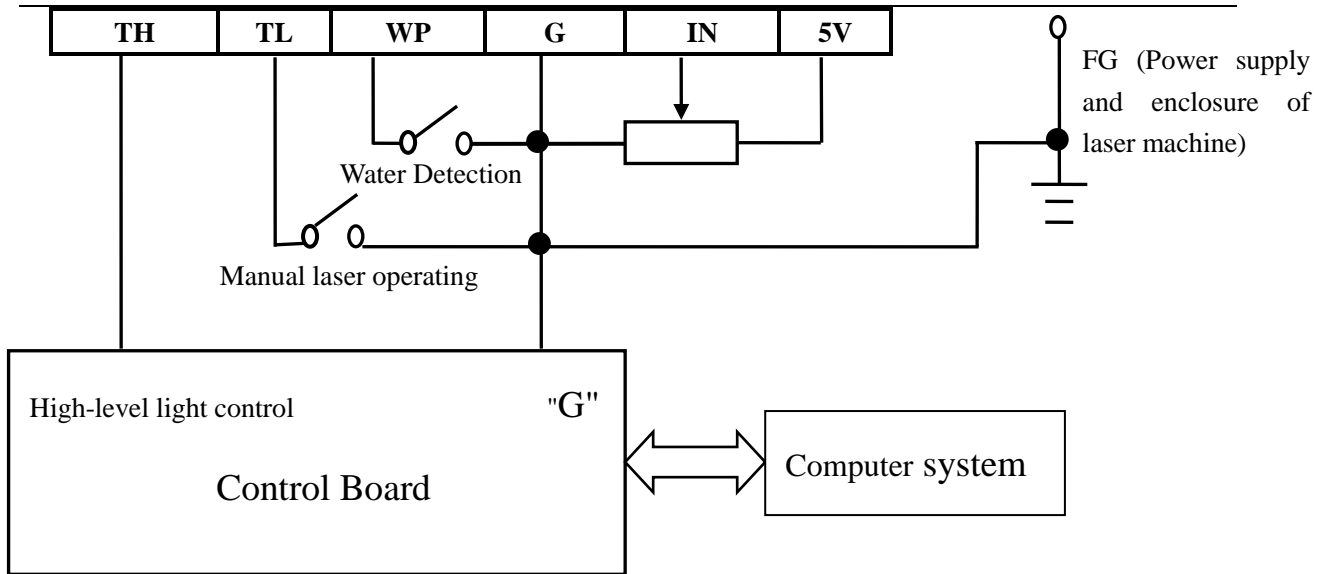

2. Recommended connection: Low-level light control

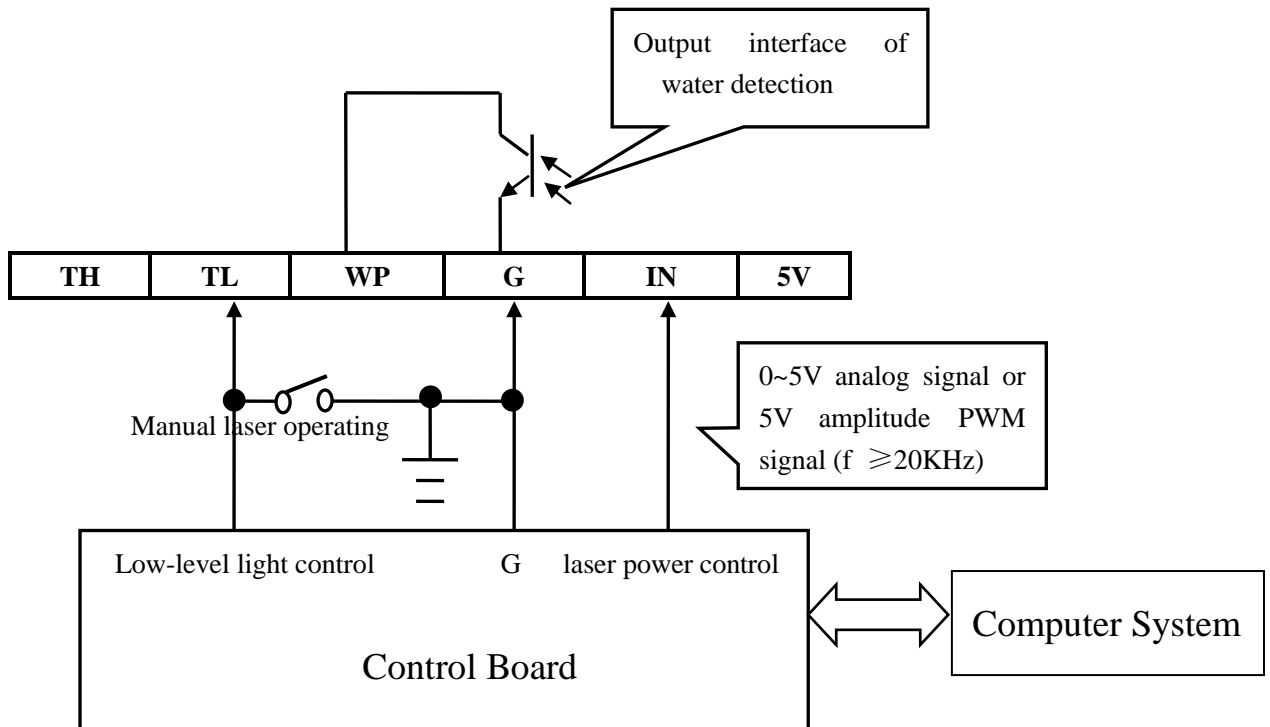

VII. Check the power supply worked properly or not manually

Make sure the power supply and laser tube wiring correct firstly, offline the control line and then press the red button "TEST" to test laser tube out light or not, this method can be simple judgment power supply is

150W Power Supply Model: HY-T150

working correctly.

VIII. Common Fault Detection and Ruled Out

Problem	Cause	Estimation	Solution
Trip after power on	1.External wiring: AC and FG reverse connection	Check if AC and FC misplaced	Connected correctly according to Instruction
	2. External wiring: short circuit between AC and AC	Use multimeter to check if short circuit between AC and AC.	Rewiring, and avoid short circuit
	3. Internal wiring: short circuit between AC and AC or AC and FG		Send back factory for maintenance
	4.Other causes		
AC power on but Fan of power supply does not work	1.Fan socket is loose.	Laser emission when manual test.	Open enclosure and tighten socket.
	2.Fan damaged	Laser emission when manual test.	Change fan or send back factory for maintenance
	3.Fuse is burned.	No laser emission when manual test.	Contact with us for repair.
AC power on but no laser emission	1.Control wire connected wrong	Check if wire is connected correctly according to Operation Instruction	Rewiring correctly
	2. Internal connector is loose.	Open outside case and check	Tighten connector.
	3.Protection switch on but on water through or water through switch is broken.	Voltage>0.5V between "WP"and"G"	Water through or change water through switch.
	4.Wrong output laser signal	Voltage between"TH " and "G" should<3V when When laser-open controlled by high level	Replace CNC card or change GND.
		Voltage between"TL" and "G" should>3V when laser-open controlled by low level.	
	5. Power control signal is 0.	Voltage between "IN"and "G" is 0.	Increase voltage between "IN"and "G".
	6.Fuse is burned.	Fan does not work	Send back factory for maintenance
7.Others		Send back factory for maintenance	
Laser emission at all times	1.When "TL" control laser: short circuit between"TL "and "G".	Voltage between"TL " and "G" =0	disconnected between"TL "and "G".
	2. Circuit is broken.		Send back factory for maintenance
	3. Switch of manual test laser emission is broken.		Change switch of manual test laser emission.
	4. Other causes.		Send back factory for maintenance
Current is	1.AC voltage is too low	Output current is always at 5mA around.	Use AC voltage regulator.
	2.Power supply and laser Device is not connected very well		Send back factory for maintenance
	3. Power control signal from CNC card is not connected very well with "IN".	Output current is always at 10mA around.	Re-connected

150W Power Supply Model: HY-T150

not increased	4.Potentiometer of power is broken.	Output current is not stable.	Change potentiometer.
	5.PWM frequency or amplitude is not suitable.		Change PWM frequency or amplitude.
	6.Internal Transformer is broken.	Output current is always at 5mA around	Send back factory for maintenance
	6. One circuit does not work.		
7.Others			
Laser head is not stable during working.	GND is not connected well.		Connect earth wire of CNC card,enclosure of power supply, with enclosure of laser machine.
Laser emission is not stable			
When two laser head works, action abnormal.			

IX.Site installation drawing size

