

Shenzhen RelFar Intelligent Technology Co., Ltd.

**FWH30-D20C-V4-T Intelligent Double
Pendulum Handheld Plumb Joint
(Double wire feed Four in One)**

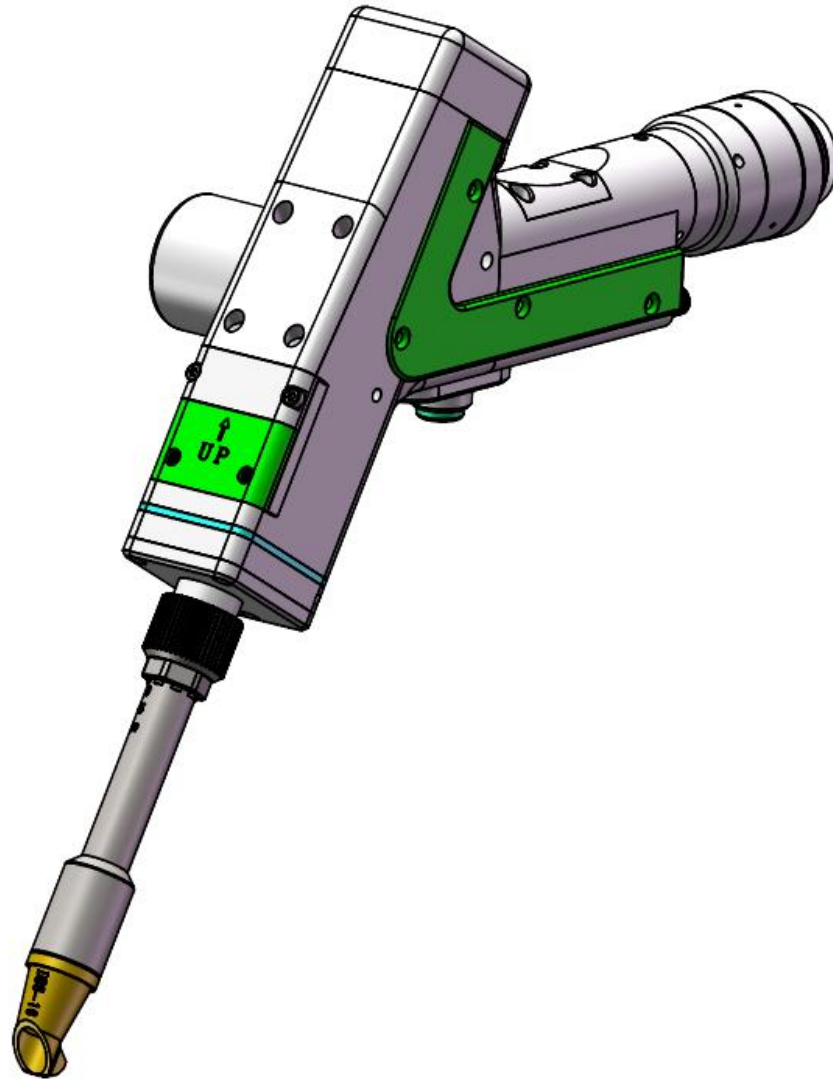

Shenzhen RelFar Intelligent Technology Co., Ltd.

Website: www.relfar.com

Tel.: 0755-23143635

**Address: 2F, Building 7, Jiuyang Industrial Park, 57 Hexiu West
Road, Baoan District, Shenzhen, Guangdong Province**

Release Date: October 16th, 2025 Version :B

Shenzhen RelFar Intelligent Technology Co., Ltd.

Foreword

Thank you for choosing our products!

To enable you to have an overall understanding of our company, there is a detailed introduction regarding features, structural features, technical parameters, instructions for use and maintenance of the product in the Manual. Before using this product, please read this Manual carefully, which will help you to use it better.

Due to constant update of product functions, the product you received may differ from the description in the Manual. We hereby express our deep sorry for this matter! During use, in case of any question, please timely call us for consultation, and we will offer dedicated service to you wholeheartedly.

Shenzhen RelFar Intelligent Technology Co., Ltd.

Contents

Chapter 1 Overview	5
1.1 Product parameter	5
1.2 Precautions	5
Chapter 2 Structural Characteristics	6
2.1 Product structure	6
Chapter 3 Product Installation	7
3.1 Pipe connection	7
3.1.1 Cooling water	7
3.1.2 Protective gas	8
3.2 Optical fiber input installation	8
Chapter 4 Maintenance	10
4.1 Structure of optics lens	10
4.2 Cleaning of optics lens	11
4.3 Disassembly and assembly of optics lens	12
4.3.1 Disassembly and assembly of collimation lens	12
4.3.2 Disassembly and assembly of focus lens	13
4.3.3 Disassembly and assembly of protective glass	14
Chapter 5 Welding System	15
5.1 Product dimension figure	15
5.1.1 Installation dimension of touch screen	15
5.1.2 Installation dimension of main board	16
Chapter 6 Electrical	17
6.1 Packing list	17
6.2 System wiring	18
6.3 CN5 power supply interface	19
6.4 CN1 wire feeder interface	19
6.5 CN2 laser interface	20
6.6 CN3 temperature sensor interface	21
6.7 HMI touch screen interface	21
6.8 CN4 reserved serial port interface	22
6.9 CN6 external start and interlock interface	22
6.10 CN7 general input interface 1	23
6.11 CN8 general output interface	23
6.12 CN9 common input interface 2	24
6.13 Galvanometer interface	24
Chapter 7 HMI Operating Instruction	25
7.1 HMI function introduction	25
7.2 HMI operation introduction	26
7.2.1 Parameter setting:	26
7.2.2 Point welding mode	27
7.2.3 Wire feeding parameter:	28

Shenzhen RelFar Intelligent Technology Co., Ltd.

7.2.4 Device parameter	28
Chapter 8 Monitoring Protection Device	30
8.1 Temperature parameter setting of Protective Lens	30
Chapter 9 Replacement of Cleaning Module	31
9.1 Replacement of structure	31
9.2 Module dismantling and replacement	32
9.3 Installation and replacement	32
Chapter 10 Processing Module Switching	33
10.1 Selection of processing type	33
10.2 Hint of module replacement	33
10.3 Switch completion	34
Chapter 11 Welding Seam Cleaning and Replacement	35
11.1 The schematic diagram for replacement of structure is as follows:	35
11.2 System switching	35
Chapter 12 Introduction to the APP	36
12.1 Function Introduction	36
12.2 Equipment connection	36
12.2.1 Connection mode	36
12.2.2 AP mode connection	37
12.2.3 STA mode connection	39
12.3 APP download method	40
12.4 APP function	41
Chapter 13 Introduction to Wisdom Cloud	42
13.1 Function Introduction	42
13.2 Smart Cloud Login	42
13.3 User Center	42
13.4 Equipment Management	43
13.5 Remote assistance	43
13.6 Technology Center	44

Chapter 1 Overview

1.1 Product parameter

Name	Intelligent double pendulum
Model	FWH30-D20C-V4-T
Fiber interface	QBH
Wavelength scope	1070±20nm
Rated power	≤ 3000W
Collimation focal length	40mm
Focus focal length	200mm
Swing type	—、○、∞、∩、⊙、△、⊗
Regulating scope of focal point	-10mm~+10mm
Regulating scope of light spot	0~8mm
Auxiliary pressure	≤1Mpa
Weight	1.0Kg

1.2 Precautions

※ To ensure personal safety, wear the special fiber laser protective glasses before operation.

※ It is necessary to keep the product clean and prevent the cooling liquid, condensate water or other foreign matter from intruding into the cavity, or the functional contamination and functional impact of related parts will be incurred.

Chapter 2 Structural Characteristics

2.1 Product structure

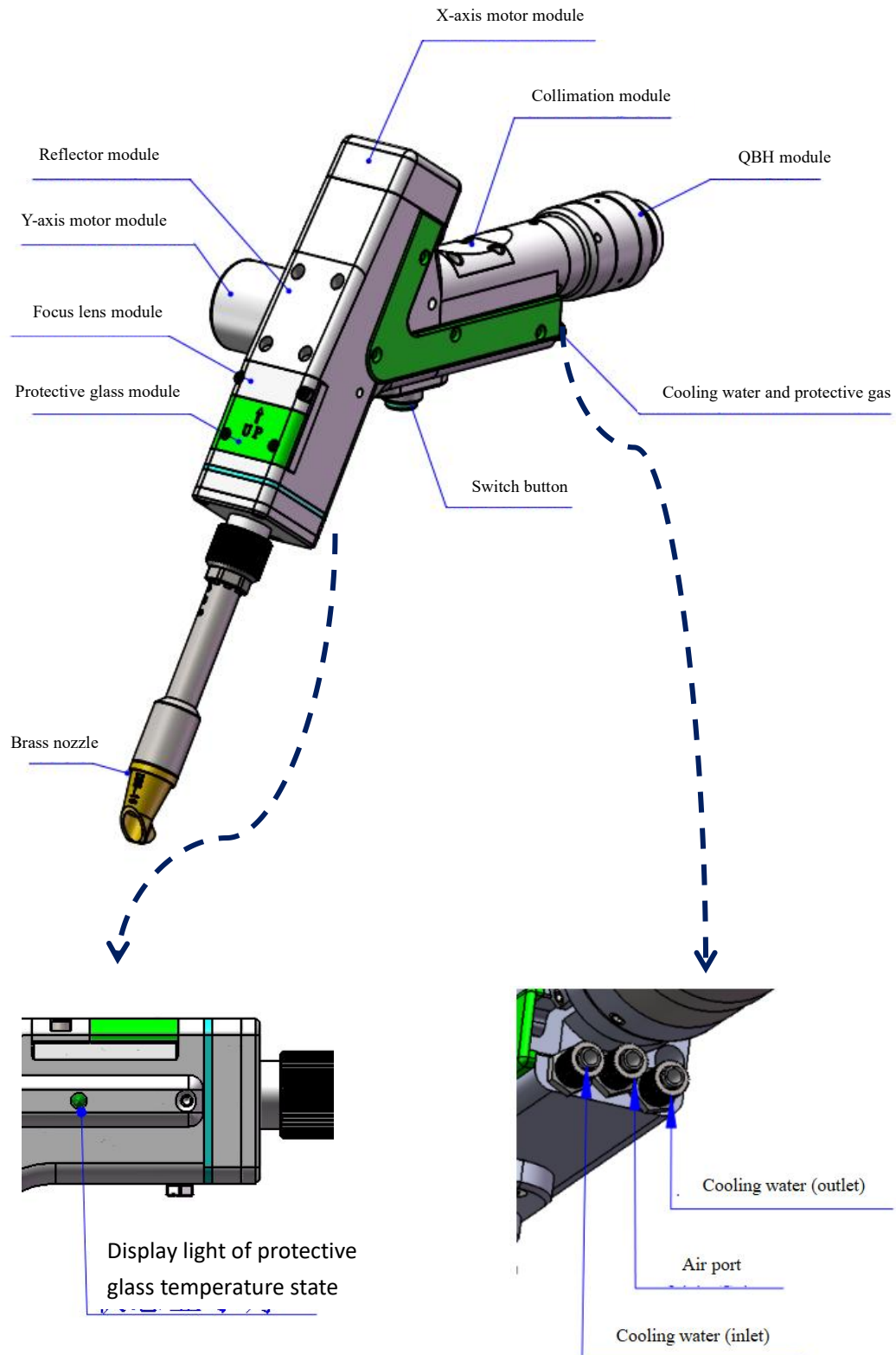

Chapter 3 Product Installation

3.1 Pipe connection

Cooling water circuit and auxiliary protective gas connection

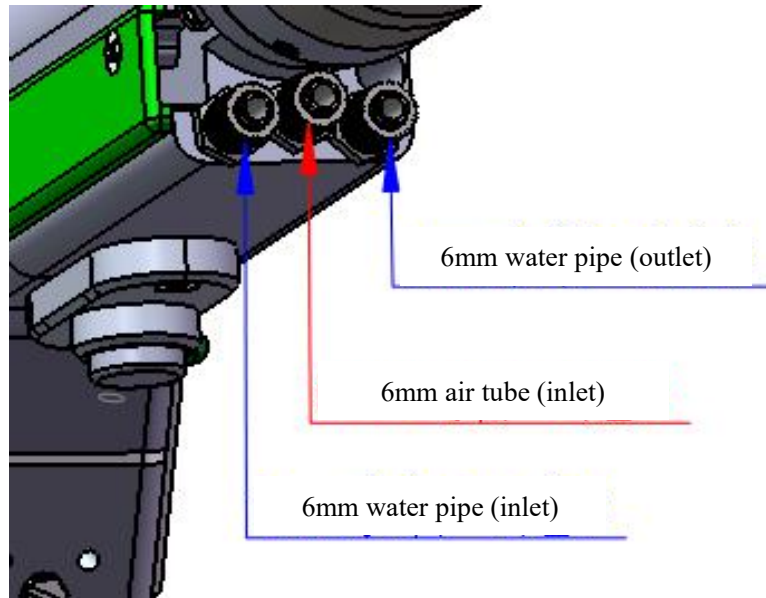

Connection of cooling water and shielding gas and usage requirements:

Note: Regularly used gases: Compressed air (oil-water filtration required)

Regularly used gases are: argon, nitrogen and compressed air (oil-water filtration required).

3.1.1 Cooling water

The 6mm air tube is connected. The main function is that the excess heat is taken away by cooling through the internal structural member water route when the heat is produced by the

Shenzhen RelFar Intelligent Technology Co., Ltd.

light path in the cavity to ensure the welding performance. The series connection of cooling water pipeline is required, with one-in and one-out water circulation connected.

3.1.2 Protective gas

The 6mm air tube is connected for butt welding gas protection, with input pressure $< 1\text{Mpa}$.

3.2 Optical fiber input installation

※ The QBH is a horizontal arrangement to take out the dustproof seal cover.

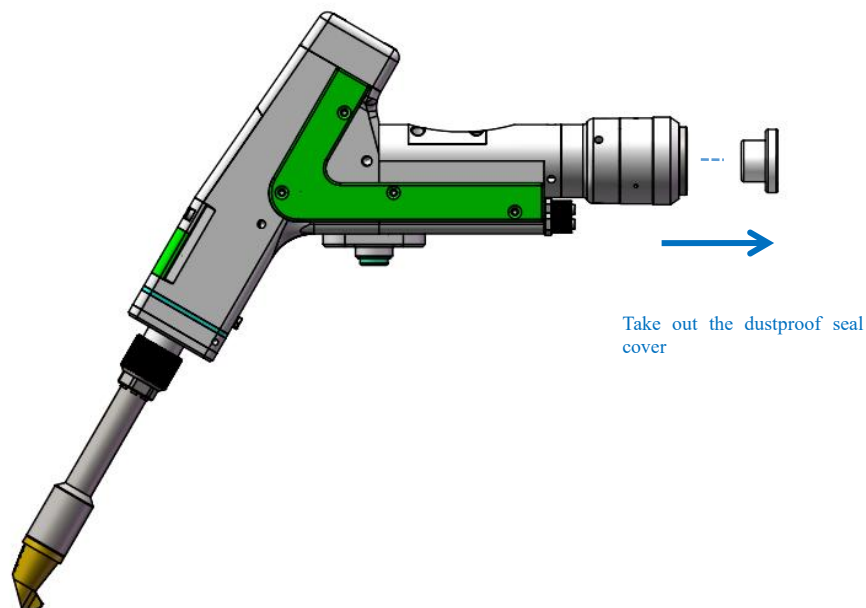

※ Align the red dot on the fiber optic head with the QBH red dot, and slowly insert the fiber optic head into the QBH.

Shenzhen RelFar Intelligent Technology Co., Ltd.

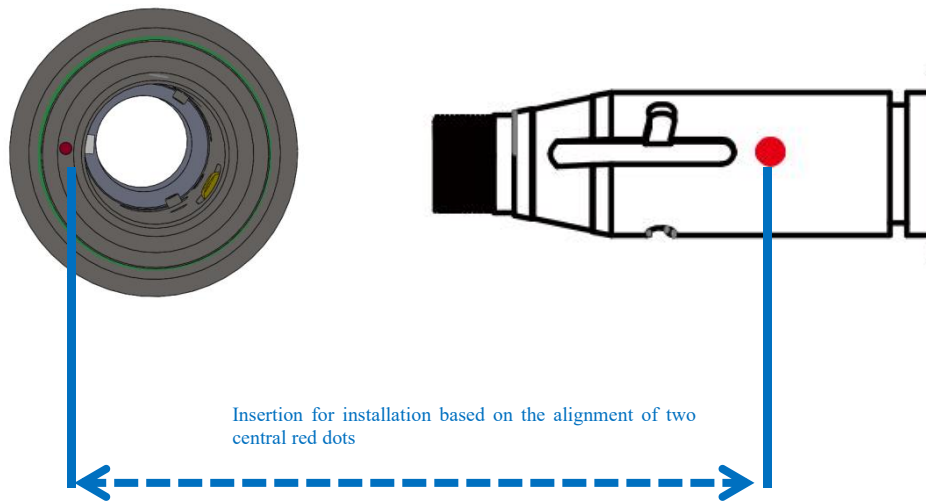

※ The QBH is screwed to the locking state: Rotate it to the limiting position clockwise (hearing the "click"), lift up the rotating mantle, and clockwise rotate the mantle until the head of optical fiber is compressed.

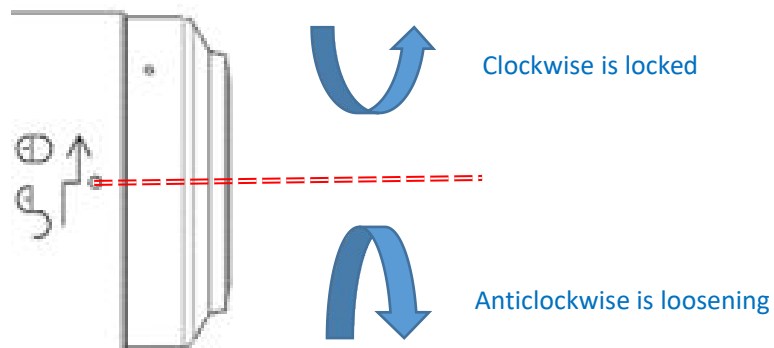

Chapter 4 Maintenance

4.1 Structure of optics lens

※ The assembly is completed in the dust-free plant at the time of replacement of parts. In principle, other modules are forbidden to be dismantled except that the protective glass drawer can be disassembled and assembled. If it is necessary to check the collimating lens, focus lens and galvanometer lens, the product shall be put into a clean environment for disassembly.

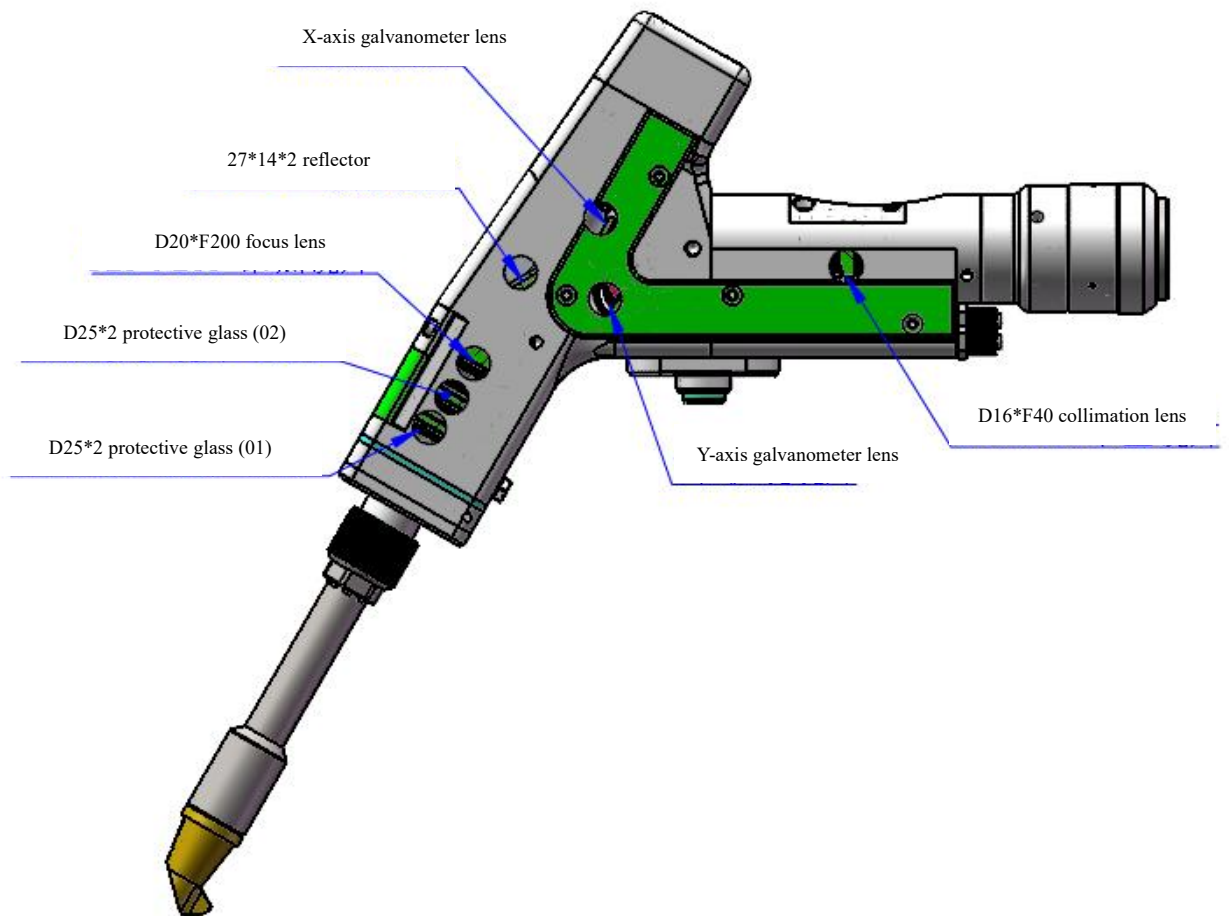

Shenzhen RelFar Intelligent Technology Co., Ltd.

4.2 Cleaning of optics lens

※ When the optics lens are cleaned, the operation method and attention points are as follows:

※ Tools: Dust-free gloves or dust-free fingerstall, dust-free wiping cotton swab, isopropyl alcohol, and caned dry and pure compressed air.

※ Spray the isopropyl alcohol onto the dust-free cotton swab, align the lens to eyes, gently pinch the side edge of the lens with left thumb and index finger and hold the dust-free cotton swab with right hand to gently wipe the front and back of the lens in a single direction from bottom to top or from left to right (avoid wiping back and forth to avert the secondary contamination of lens), blow the surface of the lens with filling dry and pure compressed air and confirm the surface of lens is free from foreign matters after cleaning.



Shenzhen RelFar Intelligent Technology Co., Ltd.

4.3 Disassembly and assembly of optics lens

4.3.1 Disassembly and assembly of collimation lens

Tools: 2mm inner-hexagon wrench, dust-free cotton swab, alcohol

※ The disassembly and assembly shall be completed in a clean place.
When the lens are dismounted, the dust-free gloves or dust-free fingerstall.

※ Disassembly and assembly steps:

Step 1: Clean up all the dust on the surface of the laser head firstly.

Step 2: Loosen the M2.5 hex socket head cap screw in the figure by hand with a 2mm hex wrench.

Step 3: Remove the collimation handle horizontally, and pull out the collimation drawer module.

Step 4: Seal the port with textured paper to prevent the dust from entering the cavity, resulting in pollution.

Step 5: Rotate the gland for 90° after pressing it downward gently and take out the gland by two bosses aligning to left/right opening to replace the collimation lens.

(Note: orientation of installed lens in the concave and convex direction)

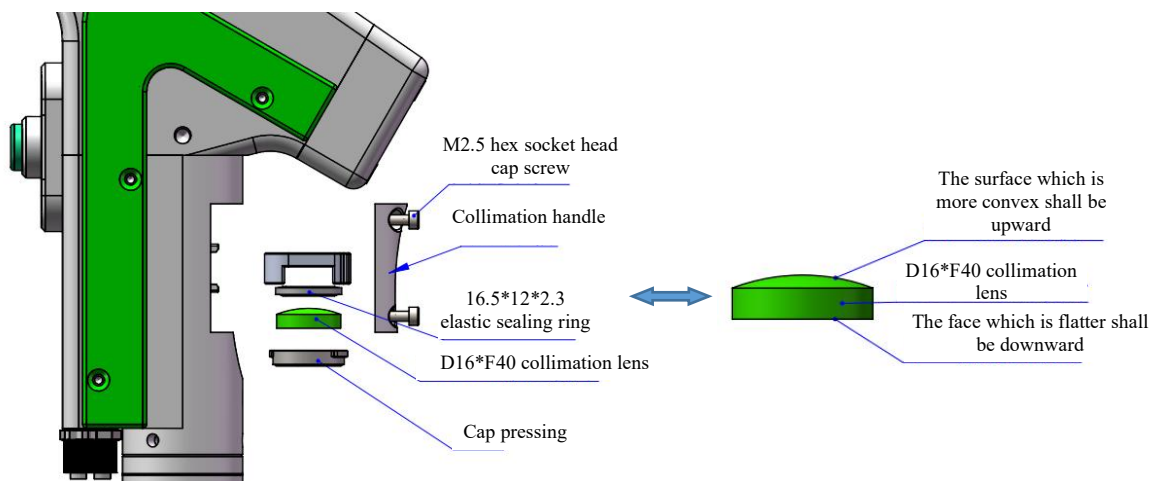

Shenzhen RelFar Intelligent Technology Co., Ltd.

4.3.2 Disassembly and assembly of focus lens

Tools: 2mm hexagon key wrench, dust-free cotton swab, ethyl alcohol and masking tape

※ The disassembly and assembly shall be completed in a clean place. When the lens are dismantled, the dust-free gloves or dust-free fingerstall.

※ Disassembly and assembly steps:

Step 1: Loosen the M2.5 hex socket head cap screw in the figure by hand with a 2mm hex wrench.

Step 2: Take out the focus drawer module by direct drawing/pulling in the horizontal direction.

Step 3: Seal the port with textured paper to prevent the dust from entering the cavity, resulting in pollution.

Step 4: Rotate the gland for 90° after pressing it downward gently and take out the gland by two bosses aligning to left/right opening to replace the focus lens.

(Note: orientation of installed lens in the concave and convex direction)

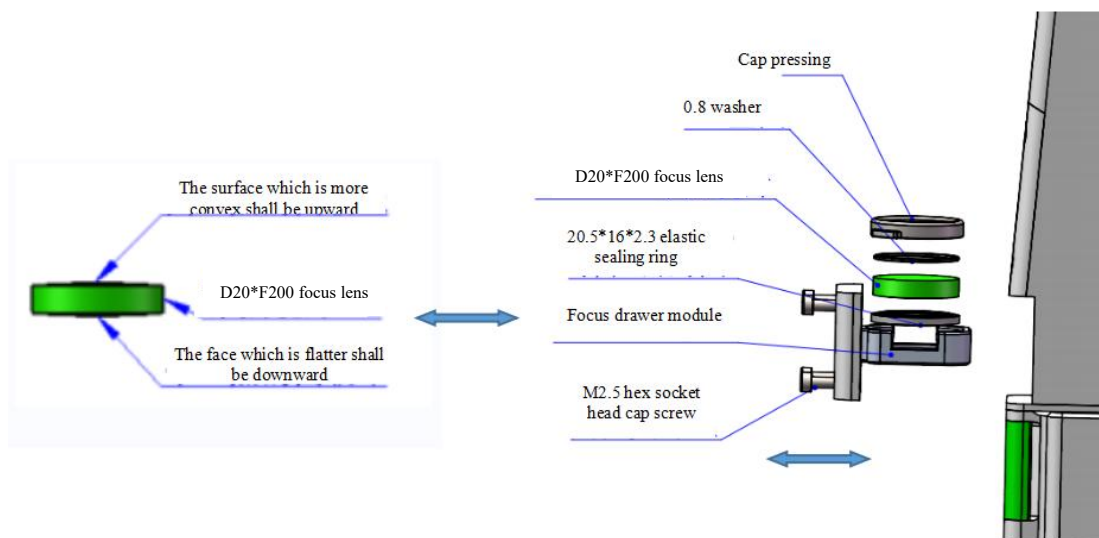

Shenzhen RelFar Intelligent Technology Co., Ltd.

4.3.3 Disassembly and assembly of protective glass

※ The disassembly and assembly shall be completed in a clean place. When the lens are dismounted, the dust-free gloves or dust-free fingerstall.

Replace the protective glass 01

Step 1: hold both sides of the handle of the green drawer module 1 with hands to draw out the protective glass in the horizontal direction. Pay attention to dust prevention and seal the exposed window on the cavity with textured paper to prevent the dust from entering the cavity, resulting in pollution, and then replace the protective glass.

Step 2: Gently press the gland down for 90° rotation, and loosen it when two lugs align to two notches to take out the gland to replace the protective glass.

Replace the protective glass 02

Step 1: Take out the green drawer handle module 1 to take out the handle module 2 in the horizontal direction. Pay attention to dust prevention and seal the exposed window on the cavity with textured paper to prevent the dust from entering the cavity, resulting in pollution, and then replace the protective glass. Gently press the gland down for 90° rotation, and loosen it when two lugs align to two notches to take out the gland to replace the protective glass.

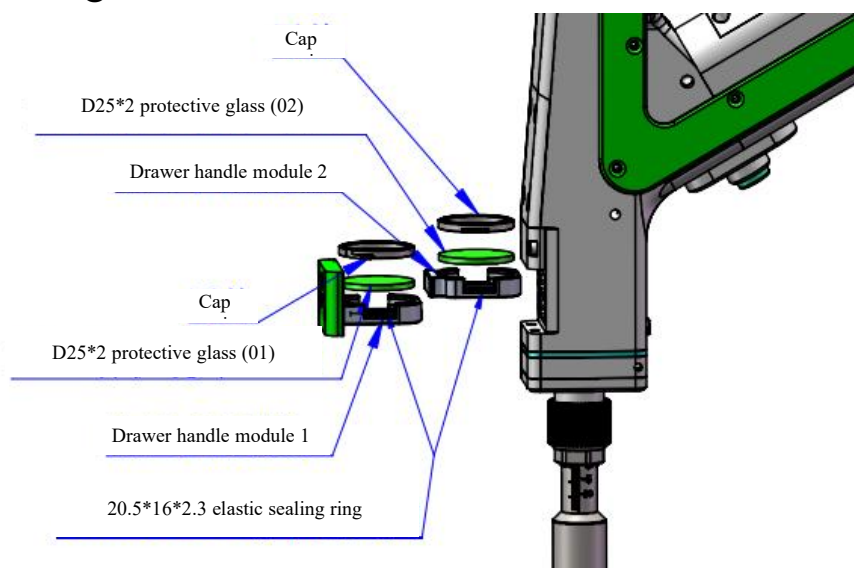

Chapter 5 Welding System

5. 1Product dimension figure

5.1.1 Installation dimension of touch screen

External dimensions: (210*150*23.5) mm

The installation dimensions of the touch screen are as shown in the following figure.:

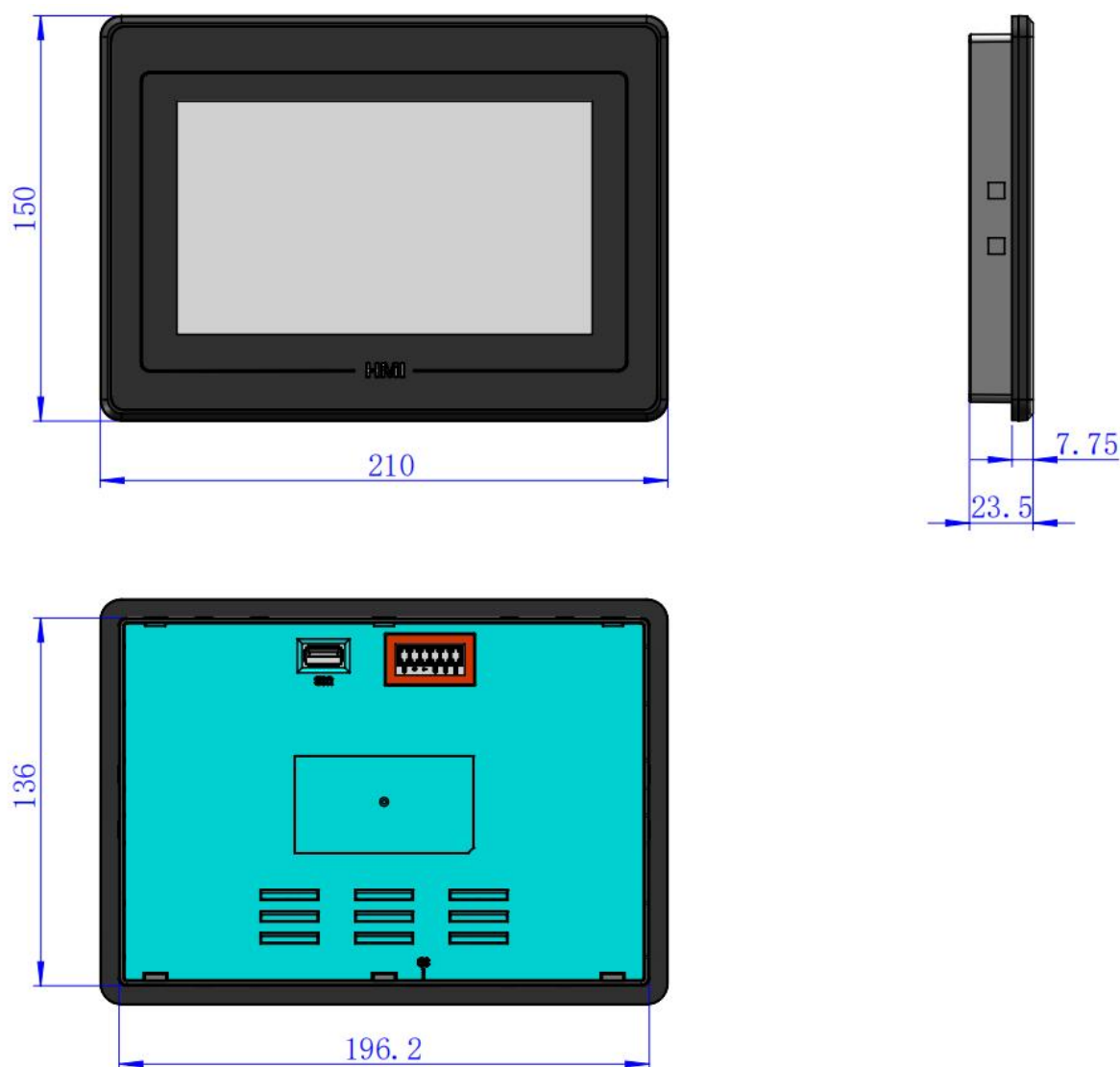

Shenzhen RelFar Intelligent Technology Co., Ltd.

5.1.2 Installation dimension of main board



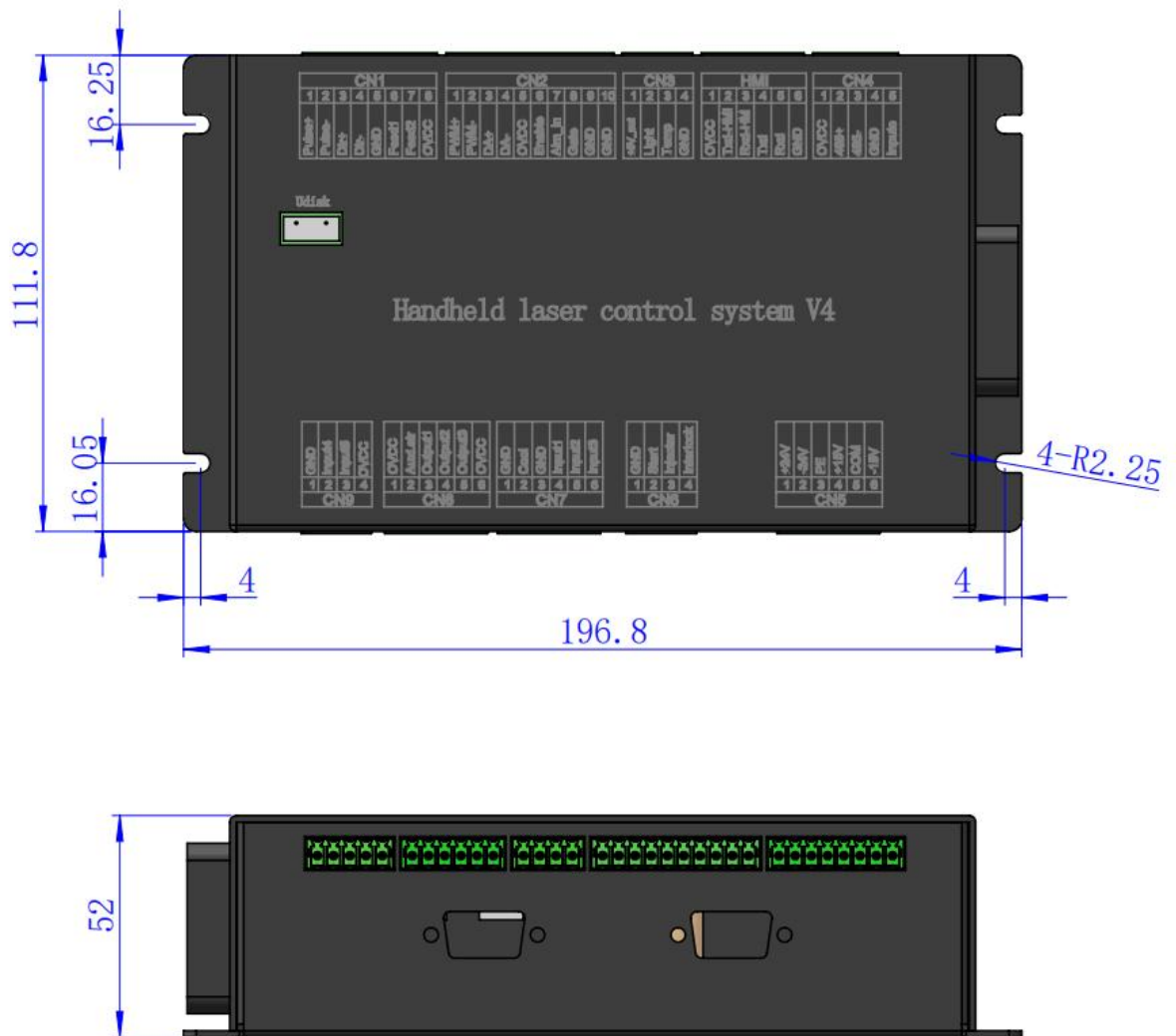



Overall dimensions: (196.8 * 111.8 * 52) mm

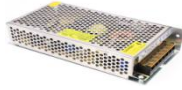

Shenzhen RelFar Intelligent Technology Co., Ltd.

Chapter 6 Electrical

6.1 Packing list

List				
S/N	Name	Illustration	Quantity	Remarks
1	Intelligent handheld welding head		1PCS	
2	24V power pack		1PCS	
3	15V power pack		1PCS	
4	Ground clamp component		1PCS	
5	7-inch display screen		1PCS	
6	Touchscreen 6-core connection cable - 1.5m - Black		1PCS	
7	Handheld Laser Welding System V4		1PCS	

6.2 System wiring

The following figure is a schematic diagram for wiring of the whole system. Refer to the schematic diagram for system wiring. Refer to relevant chapters for detailed interface definition.

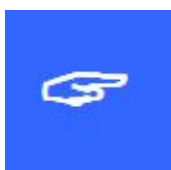
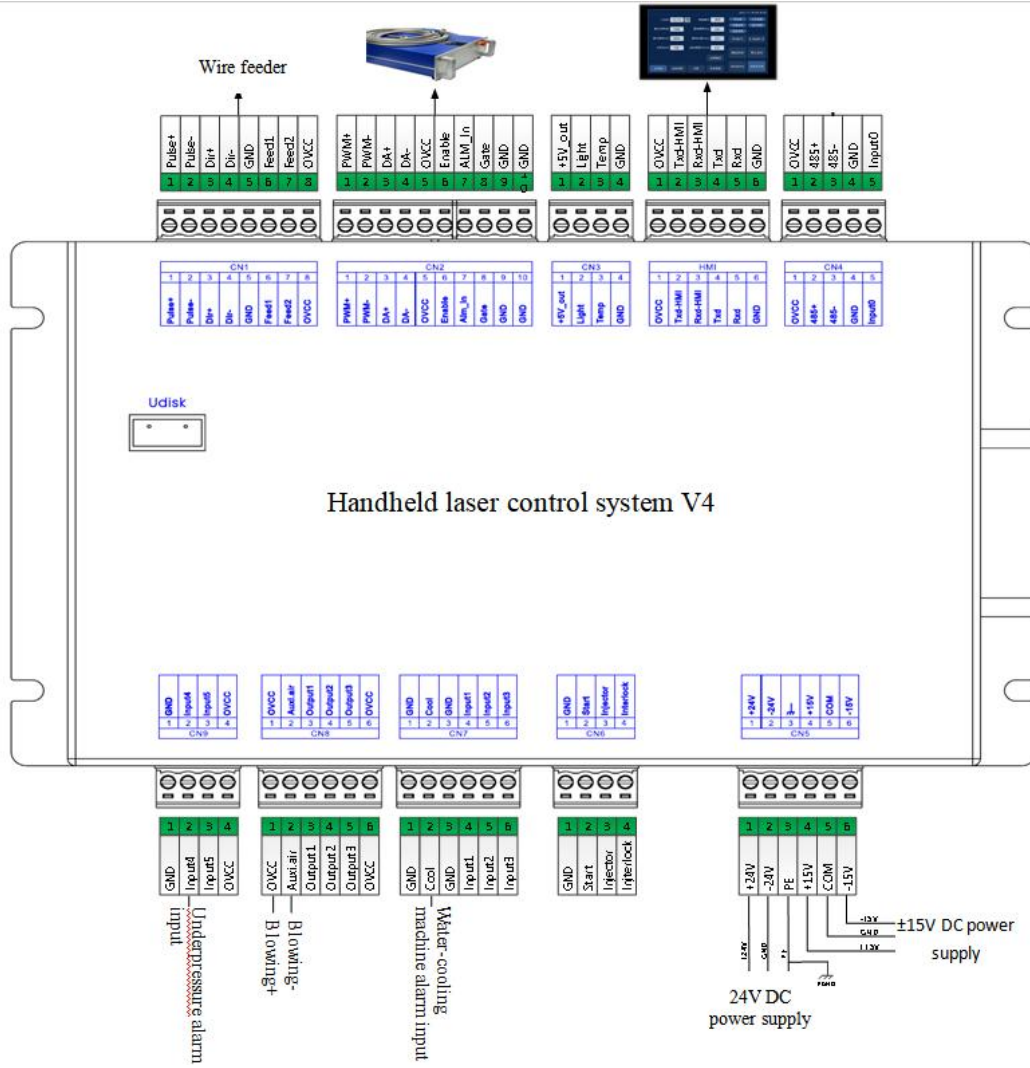

Note:
Don't connect the reserved pin in the mainboard.

Shenzhen RelFar Intelligent Technology Co., Ltd.

6.3 CN5 power supply interface

The power supply interface all into 6 PIN green terminal, providing a power interface for mainboard and galvanometer externally, with voltage: DC 24V (DC 24V) and DC $\pm 15V$ (DC ± 15).

Table 6.3.1 shows the definition of CN5 power supply interface.

Table 6.3.1

Pin	Signal	Definition	Instruction
1	24V+	Power supply input	+24V external power input and power supply output current: above 2.5A
2	24V-	Power reference ground	—
3	PGND	External shielding ground	Generally connecting to ground or enclosure
4	+15V	Power supply input	+15V external power input and power supply output current: above 2A
5	GND	Power reference ground	—
6	-15V	Power supply input	-15V external power input and power supply output current: above 2A

6.4 CN1 wire feeder interface

The interface CN1 of the wire feeding machine is an 8-pin green terminal, which supports both motor wire feeding and IO wire feeding. Table 6.4.1 provides the definition of the wire feeding machine interface.

Table 6.4.1

Pin	Signal	Definition	Instruction
1	Pulse+	Motor wire feed pulse + interface	The motor wire feed is used, and the driver PUL+ is connected
2	Pulse-	Motor wire feed pulse - interface	Motor wire use, connected to drive PUL-
3	DIR+	Motor wire feed direction + interface	Motor wire wire, connected to driver Dir+
4	DIR-	Motor wire feed direction - interface	Motor wire used, connected to drive Dir-
5	GND	Reference ground	—

Shenzhen RelFar Intelligent Technology Co., Ltd.

6	Feed 1	Common terminal of the direct current wire feeding machine	When the direct current wire feeder is feeding the wire, the connection is made.
7	Feed 2	Direct current wire feeder typically starts operation	When the direct current wire feeder is feeding the wire, the connection is made.
8	OVCC	+24V power output	Power supply, maximum output is 500mA

6.5 CN2 laser interface

The laser interface is a 8PIN green terminal. Table 6.5.1 shows the definition of laser interface.

Table 6.5.1

Pin	Signal	Definition	Instruction
1	PWM+	Modulated signal +	Duty cycle adjustable from 1% to 99%, 24V level
2	PWM-	Modulated signal-	Duty cycle adjustable from 1% to 99%, 24V level
3	DA	Simulated voltage output	0-10V analog voltage, used for adjusting the peak power of the laser
4	GND	Power reference ground	Generally, it connects to the laser control interface DA-
5	OVCC	+24V power output	Power supply, capable of delivering a maximum output of 500mA
6	Enable	Laser enable signal	24V voltage level, with high level as the valid state
7	Alarm_in	Laser failure alarm input	—
8	GATE	Red light indication signal	24V voltage level, with high level as the valid state
9	GND	Signal reference ground	Red light—
10	GND	Signal reference ground	Red light—

Shenzhen RelFar Intelligent Technology Co., Ltd.

6.6 CN3 temperature sensor interface

The temperature sensor interface CN3 is a 4PIN green terminal. Table 6.6.1 shows the definition of temperature sensor. The user directly inserts the supporting connection line with terminal.

Table 6.6.1

Pin	Signal	Definition	Instruction
1	+5V_out	Sensor P interface	+5V power supply, maximum output is 500mA
2	Light	Sensor L interface	—
3	Temp	Sensor T interface	—
4	GND	Sensor G interface	—

6.7 HMI touch screen interface

The HMI interface is a 6PIN green terminal and power supply to and communication with HMI by the mainboard are performed via the port. Table 6.7.1 shows the definition of HMI interface.

Table 6.7.1

Pin	Signal	Definition	Instruction
1	OVCC	+24V power output, 500mA	Panel power supply
2	TXD_HMI	Connecting to the HMI sending end	Serial port communication TXD signal
3	RXD_HMI	Connecting to the HMI receiving end	Serial port communication RXD signal
4	TXD	Reserved communication interface	RS232 reserved communication interface
5	RXD	Reserved communication interface	RS232 reserved communication interface
4	GND	Power reference ground	—

Shenzhen RelFar Intelligent Technology Co., Ltd.

6.8 CN4 reserved serial port interface

CN4 reserved serial port interface is a 5-pin green terminal without wiring. Chart 6.8.1 shows the definition of CN4 interface.

Table 6.8.1

Pin	Signal	Definition	Description
1	OVCC	+24V power supply, 500mA	Power supply
2	485+	TXD signal	Serial communication TXD signal
3	485-	RXD signal	Serial communication RXD signal
4	GND	GND	—
5	Input0	Reserved input interface	

6.9 CN6 external start and interlock interface

The CN6 interface is a 4PIN green terminal. Table 6.9.1 shows the definition of CN6 interface.

Table 6.9.1

Pin	Signal	Definition	Instruction
1	GND	Reference ground	Generally connecting to the start button switch on the welding head-
2	Start	External start switch input	Generally connecting to the start button switch on the welding head+
3	Injector	Safety clamp signal input	The pin must be connected to the safety clamp and the safety clamp shall be clamped onto the metal material before welding.
4	Interlock	Safety lock signal input	The pin must be connected to the nozzle of the handheld head. The nozzle touches the metal material at the moment of welding.

Shenzhen RelFar Intelligent Technology Co., Ltd.

6.10 CN7 general input interface 1

The CN7 interface is a 6PIN green terminal and of NPN type. Table 6.10.1 shows the definition of CN7 interface.

Table 6.10.1

Pin	Signal	Definition	Instruction
1	GND	Reference ground	—
2	Cool	Water-cooling machine alarm input	NPN type input
3	GND	Reference ground	—
4	Input1	Reserved	NPN type input
5	Input2	Reserved	NPN type input
6	Input3	Reserved	NPN type input

6.11 CN8 general output interface

The CN8 interface is a 6-pin green terminal. By using the OC output, it can directly drive relays, with a maximum current of up to 500mA. The wiring diagram is shown in Table 6.11.1.

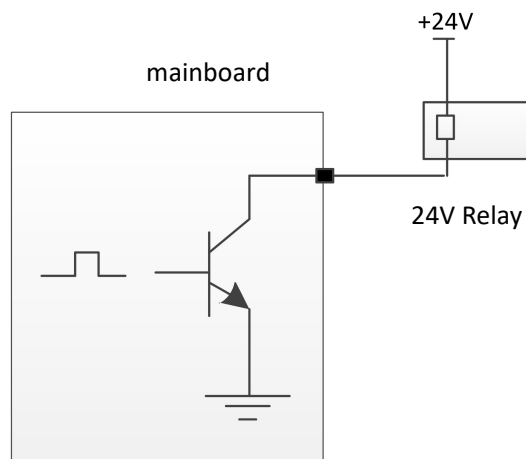

Output terminal relay wiring diagram

Shenzhen RelFar Intelligent Technology Co., Ltd.

Table 6.11.1

Pin	Signal	Definition	Instruction
1	OVCC	+24V power output	Power supply, capable of delivering a maximum output of 500mA
2	Auxi.air	shielding gas	Used for gas blowing control protection, it can directly drive the solenoid valve
3	Output1	green light	output 0V in standby mode
4	Output2	yellow light	0V output in processing state
5	Output3	red light	and 0V output in alarm state
6	OVCC	+24V power output	Power supply, capable of delivering a maximum output of 500mA

6.12 CN9 common input interface 2

The CN9 interface is a 4-pin green terminal of NPN type. The definition of the CN9 interface is given in Table 6.12.1.

Table 6.12.1

Pin	Signal	Definition	Instruction
1	GND	Reference ground	—
2	Input4	Underpressure alarm input	
3	Input5	Reserved	—
4	OVCC	+24V power output	Power supply, maximum output is 500mA

6.13 Galvanometer interface

The system provides two DB9 galvanometer interfaces, one DB9 male connector and one DB9 female connector.

Chapter 7 HMI Operating Instruction

7.1 HMI function introduction

Handheld laser welding control system operating panel (“HMI” for short) adopts a 7-inch configuration TFT touch screen with beautiful interface and convenient operation. It can set laser related parameters. On the main interface, the input and output IO status, alarm information and motion state can be displayed in real time. Refer to the following figure for the HMI main interface.

Main interface of HMI



Swing off: to set galvanometer motor swing on or off

Safety lock: to start or close the safety lock. When the lock is started, during the welding, the laser will stop when the welding head does not touch the welding material.

Automatic wire feeding off: to control whether to start automatic wire feeding during welding. It will start automatic wire feeding only when laser emits light.

Emit laser: to start emitting laser or stopping emitting laser

Alarm status area: when alarm signal enables, protective gas low pressure, cool water flow alarm, laser alarm and temperature alarm status will be displayed in real

Shenzhen RelFar Intelligent Technology Co., Ltd.

time. When the safety lock is started, its status will be displayed in real time. When the alarm signal is not triggered, the alarm icon is blue; when it is triggered, the alarm icon is blue and red alternately.

Homepage/ Wire feeding parameter/ Diagnosis/ System parameter: to display the type of parameter on the current page. Click an icon to enter the switch of the corresponding parameter page. For instance, if the icon on the homepage turns on, the parameter in the current display area is the parameter of the homepage. When it needs to switch to wire feeding parameter, just click the position of wire feeding, and the icon of this parameter will turn on.

Blowing manually/ Wire feeder: for manual blowing test and the wire feeding and wire withdrawing tests of wire feeder. For example, long press manual blowing key, and it will blow all the time; loosen this key, and it will stop blowing. For manual wire feeding and wire withdrawing, long press the corresponding small triangle area.

7.2 HMI operation introduction

7.2.1 Parameter setting:

Parameter setting includes: Home page, System parameter, Wire feeding parameter and Diagnosis page

Home page: used to set parameters related to laser, swing and process library when welding.

Process library: click the white box area in process library. The set process library parameter can be selected.

Welding model: to set welding mode, continuous and pulse modes.

Power: to set the peak power of laser when welding

PWM frequency: used to set the frequency of laser PWM modulating signal

Duty cycle: used to set duty cycle of PWM signal with the range from 1% to 100%

Swing frequency: used to set motor swing frequency

Shenzhen RelFar Intelligent Technology Co., Ltd.

Swing length: used to set motor swing length

Wire feeding parameter: used to set system parameter, including wire feeding, slow rise and fall parameters

Light emission time: the time that processing lasts when single point welding mode is set.

7.2.2 Point welding mode

click to enter the single point light emission mode

System parameter: used to set the basic parameters of device. Generally, the setting is performed by manufacturers. Before entering the page, users need to enter password.

System password: 666888

Pulse on time: the time to start light emission in pulse mode

Pulse off time: the time to stop light emission in pulse mode

Slow rise time: used to set the time that the laser analog voltage rises from initial power to the maximum power when it is enabled.

Slow fall time: used to set the time that laser analog voltage falls from the maximum power to initial power when it is stopped.

Light on power: used to set the initial power of laser, the percentage of welding power

Light on asymptotic time: the time to control the light on power of laser to rise slowly to the set power

Light off power: used to set the light off power of laser, the percentage of welding power

Light off asymptotic time: the time to control the light off power to fall slowly

Language: to switch language

Advance gas on delay: when starting processing, users can set gas activation delay. When the external start button is pressed, after blowing delay for some time, the laser can emit light.

Gas off delay: when stopping processing, users can set gas closure delay. When

Shenzhen RelFar Intelligent Technology Co., Ltd.

processing is stopped, stop the laser first. After delay for some time, stop gas blowing.

Automatic swing: used to set whether the galvanometer swings automatically.

When automatic swing function is enabled and the safety lock is connected, But if the safety lock is not connected, make the motor not carry out automatic swing after delay for some time.

Device parameter: used to switch to the device parameter page. It requires password.

Authorization: for the authorization management of mainboard

Device number: used to set the bluetooth number of control system. When users have multiple devices, they can define the number for management.

Offset in middle: for the setting of the offset in middle of red light.

7.2.3 Wire feeding parameter:

used to set parameters related to wire feeding, wire supplement and withdrawal.

Wire withdrawal speed: the wire withdrawal speed of motor when the start button is loosened.

Wire withdrawal time: the time for motor wire withdrawal

Wire supplement speed: the speed of motor wire supplement

Wire supplement time: the time for motor wire supplement

Wire feeding delay time: wire feeding after light delay for a period, generally it's 0.

Continuous wire feeding: used to change wire for the wire feeder. Click once for continuous wire feeding, click again to stop it.

Continuous wire withdrawal: used to change wire for the wire feeder. Click once for continuous wire withdrawal, click again to stop it.

Diagnosis: to monitor the IO status of current system

7.2.4 Device parameter

used to set parameters related to device

Laser rated power: used to set the rated power of laser

Maximum deflection angle of galvanometer: used to set the range of the

Shenzhen RelFar Intelligent Technology Co., Ltd.

maximum deflection angle of galvanometer.

Maximum frequency: set the maximum frequency of laser PWM signal. When PWM frequency set by welding parameter exceeds the maximum frequency, the frequency will be limited to the maximum value.

Maximum swing length: set the maximum length during swing. When the length set by welding parameter exceeds the maximum length, the length will be limited to the maximum length.

Wire feeding step: used to set the step during motor wire feeding.

Direction of motor wire feeding: used to set the direction polarity of motor wire feeding.

Galvanometer correction coefficient: when there is a nuance in the set length and the actual length, it can be modified by this parameter. When there is no need for correction, it is usually set as 1.

Lens temperature alarm enable: enable lens temperature alarm. When the temperature exceeds the limited value, the alarm signal will be generated.

Lens temperature alarm limited value: the limited value of lens temperature

Laser alarm enable: used to enable laser alarm. When laser generates alarm, the alarm signal will be generated.

Laser alarm level: used to set laser alarm to trigger the level logic.

Water-cooling machine alarm enable: used to enable water cooling machine alarm. When the water cooling machine generates alarm, the alarm signal will be generated.

Water-cooling machine alarm level: used to set water-cooling machine alarm to trigger the level logic.

Low pressure alarm enable: used to enable gas alarm. When gas low pressure generates alarm, the alarm signal will be generated.

Low pressure level: used to set low pressure alarm to trigger the level logic.

Chapter 8 Monitoring Protection Device

8.1 Temperature parameter setting of Protective Lens

[Home Page]→[System Parameter]→[Equipment Parameter]→[Input Password: 666888] →next page→ lens temperature alarm limit value.

It is suggested to set the set value of lens temperature to 50. After the lens temperature exceeds the set value, the alarm caution will arise on the home page and the display light on the side of the handheld plumb joint will turn to red.

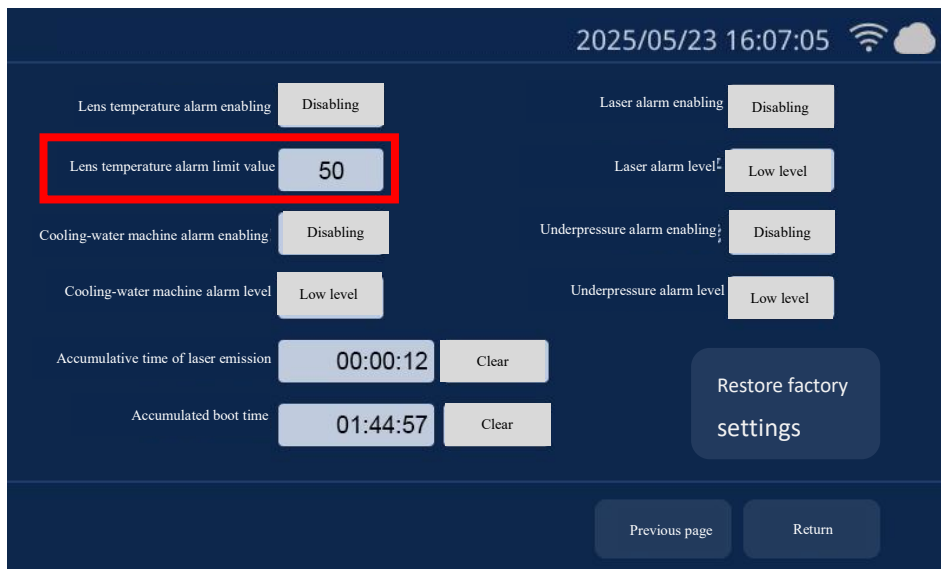

Chapter 9 Replacement of Cleaning Module

9.1 Replacement of structure

The schematic diagram is shown below

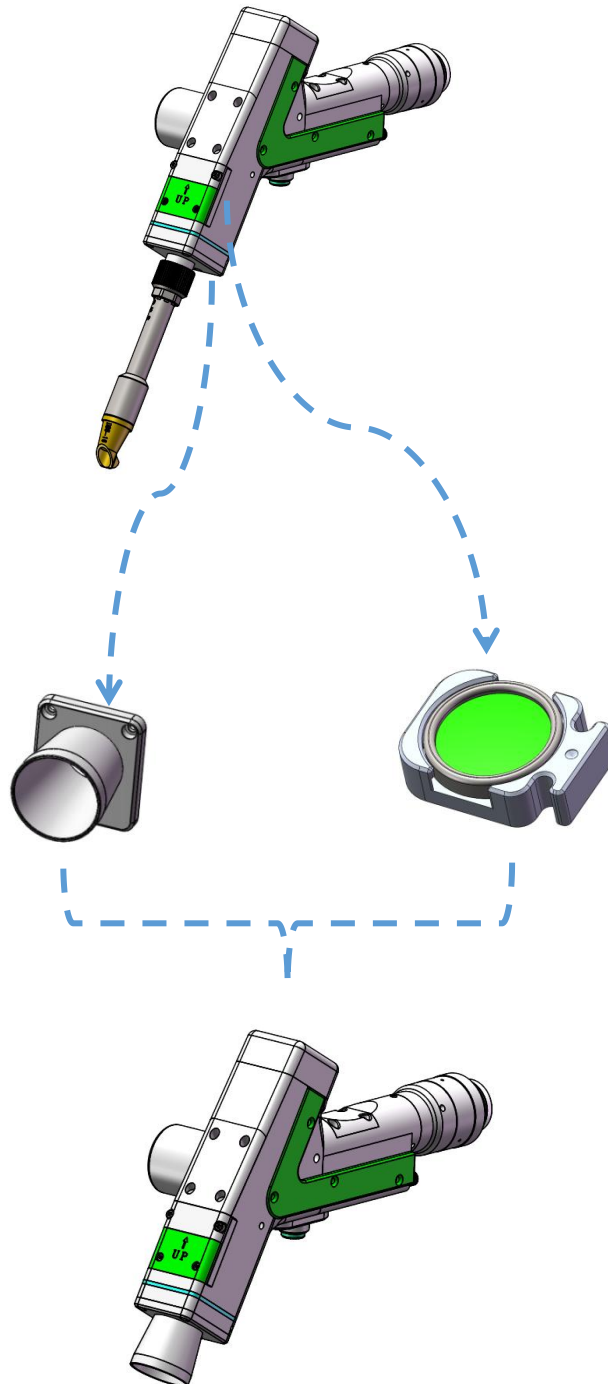

Shenzhen RelFar Intelligent Technology Co., Ltd.

9.2 Module dismantling and replacement

[Wire Feed Holder Module]: Loosen the 2-M3 screw to take out the module (Figure 1)

[Brass Nozzle Connecting Base]: Loosen the 3-M2.5 screw to take out the module (Figure 2)

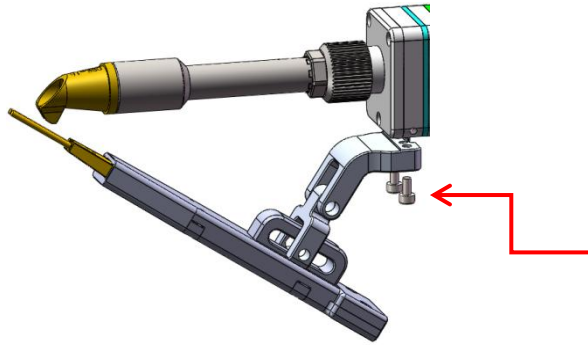

Figure 1

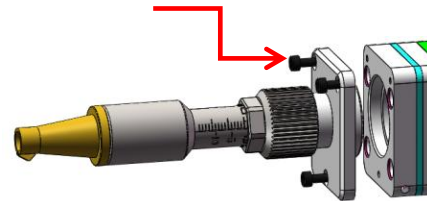
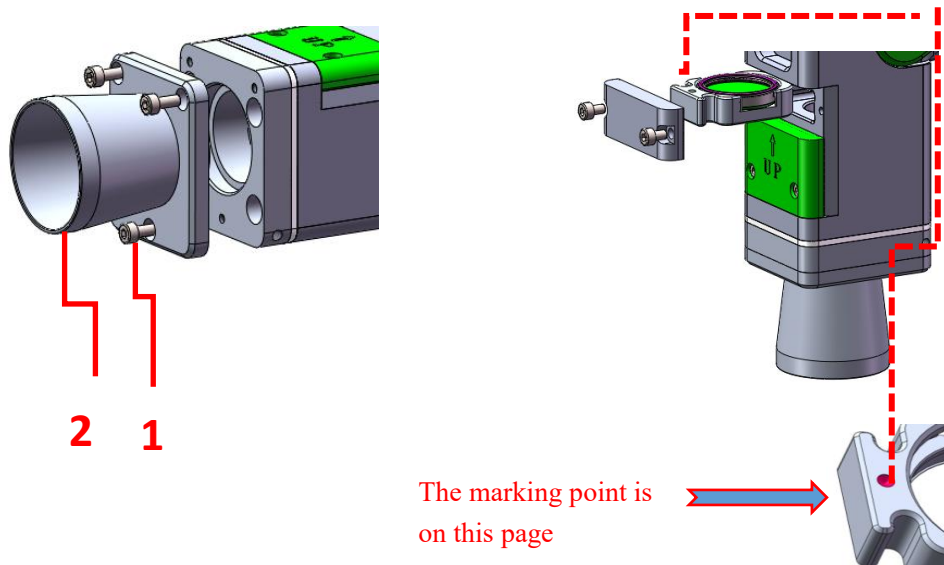

Figure 2

9.3 Installation and replacement

[Jacket Installation]: Installation pursuant to the sequence-1, 2 and 3.

[Installation of Focus Drawer]: Loosen the 4-M2.5 screw to directly draw out the focus module. Notice the small dot in the middle is in the upper part when the focus module is replaced and cleaned. The welding focus module replaced shall be subject to dustproof protection for use and replacement.



Chapter 10 Processing Module Switching

10.1 Selection of processing type

As for the welding mode switching to 100mm cleaning mode, inputting password-666666 will be reminded by clicking [Processing Type] on the panel pursuant to [System Parameter]->[Authorization]->[Processing Type]. After the password is put correctly, enter the system type selection interface, as shown in the figure:

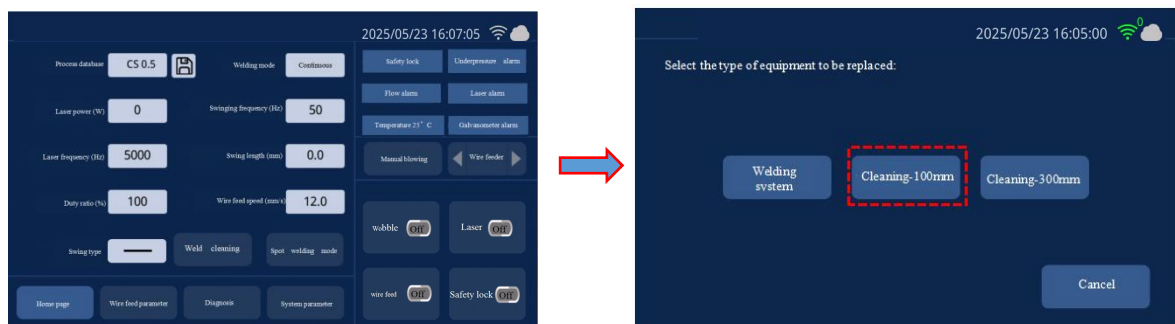

10.2 Hint of module replacement

After the user chooses the processing type, the system shall use the

Shenzhen RelFar Intelligent Technology Co., Ltd.

text and picture for prompting for the gun head component to be replaced. The system will remind power-on anew by clicking [Confirm] after the user confirms the corresponding hardware components and replacement conditions. The equipment is powered down by the use interface to replace the corresponding component.

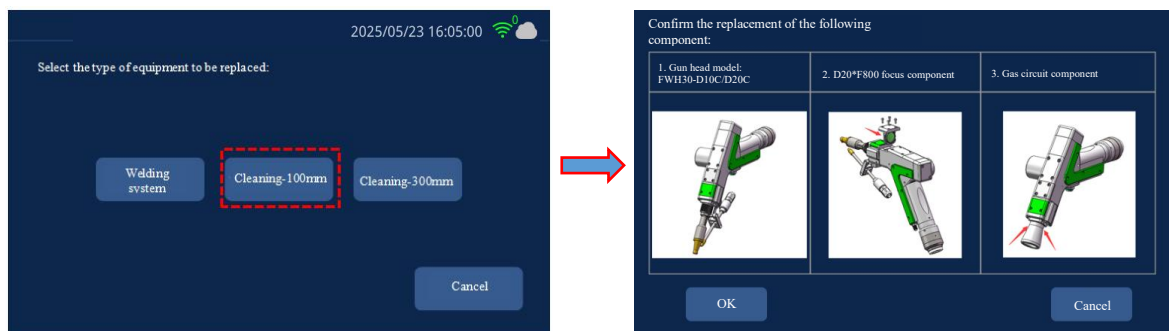

10.3 Switch completion

After the replacement of hardware component by the user is over, the equipment can be powered on anew. Whether you confirm the replacement of the hardware component will be reminded again at the moment. The user shall click [Confirm] after confirming the replacement of component is over and the system processing mode switch will be over.

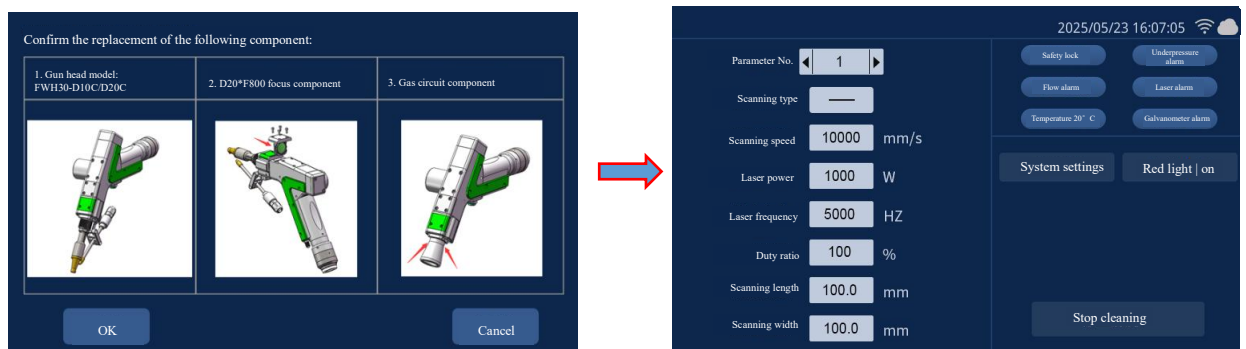

Chapter 11 Welding Seam Cleaning and Replacement

11.1 The schematic diagram for replacement of structure is as follows:

Remove the welding nozzle and replace the special nozzle for welding seam cleaning.



11.2 System switching

The system is easy to switch, and the maximum width of welding seam cleaning is 12 mm.

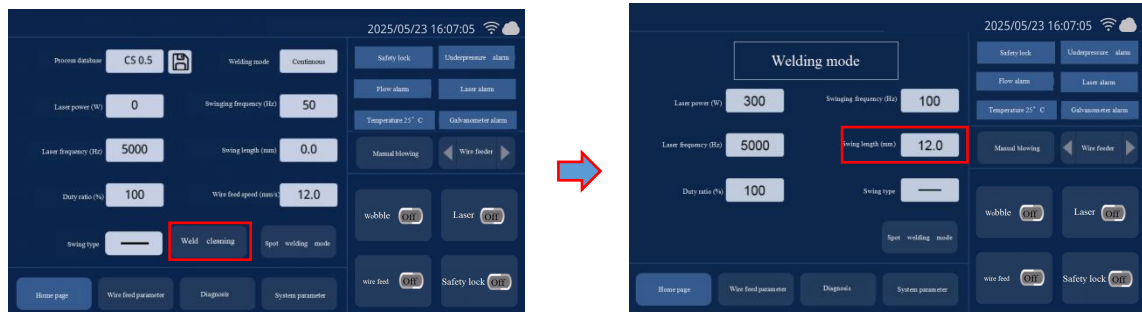

Chapter 12 Introduction to the APP

12.1 Function Introduction

The RDWelder mobile APP is an application suitable for remote control of handheld welding products, supporting various types of product applications such as single pendulum welding, double pendulum welding, single pendulum cleaning, and double pendulum cleaning. Users can connect the board card through this APP to achieve the purpose of wireless connection control. It can effectively solve the problem of the processing station being far from the equipment and constantly traveling back and forth. It supports remote viewing of equipment status and parameter adjustment, facilitating equipment management and maintenance. The APP also has rich technical center resources. It is provided for customers to install and maintain equipment, review process data, assist in troubleshooting, and refer to application cases.

12.2 Equipment connection

12.2.1 Connection mode

The handheld APP and control card support two connection modes: AP mode and STA mode.

- In AP mode, the APP is directly connected to the control card. The control card emits a WIFI hotspot signal. Customers can use mobile devices such as mobile phones to connect to the WIFI hotspot signal emitted by the control card. After the connection is completed, the board card can be controlled using the APP. Both the touchscreen and the APP use WIFI ICONS for status display.

Shenzhen RelFar Intelligent Technology Co., Ltd.

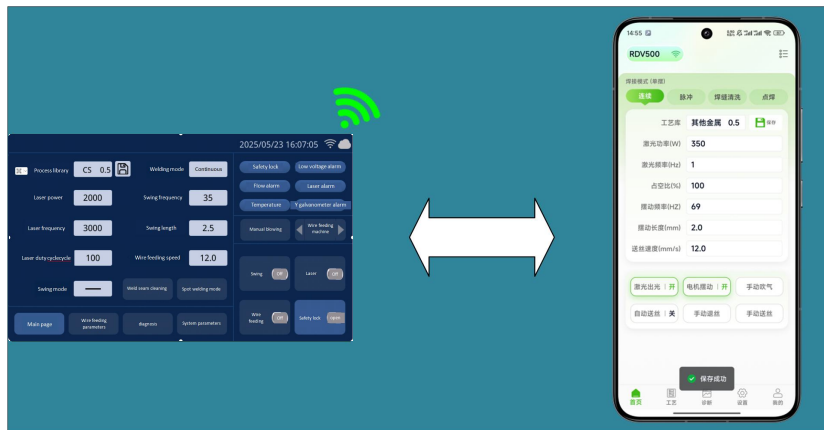

- In STA mode, the APP and the control card are connected to the cloud via the Internet. After setting the control card to STA mode, it is necessary to connect to WIFI to access the network. Access the server through traffic data to obtain the device status and perform operation control. Both the touchscreen and the APP use Internet of Things cloud ICONS for status display.

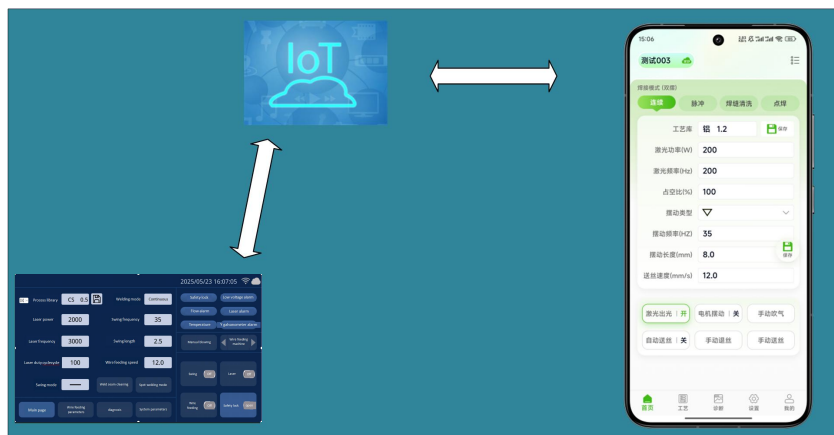

12.2.2 AP mode connection

Board card Settings:

- Click the upper right corner of the touch screen to enter the WIFI configuration page and configure the WIFI hotspot.
- Set the connection mode to AP and set the name and password of the WIFI hotspot. If the WIFI is turned on, you need to first click the < Turned On > button to turn off the WIFI. When the WIFI icon goes off, you will enter the configurable WIFI setting state.
- After the configuration is completed, click the < Turn on WIFI > button, and the system will turn on WIFI again.

Shenzhen RelFar Intelligent Technology Co., Ltd.

- After the WIFI hotspot configuration is completed, the WIFI configuration mode will be turned off, the WIFI icon will light up, and the mobile phone APP can connect to the WIFI on the board card.

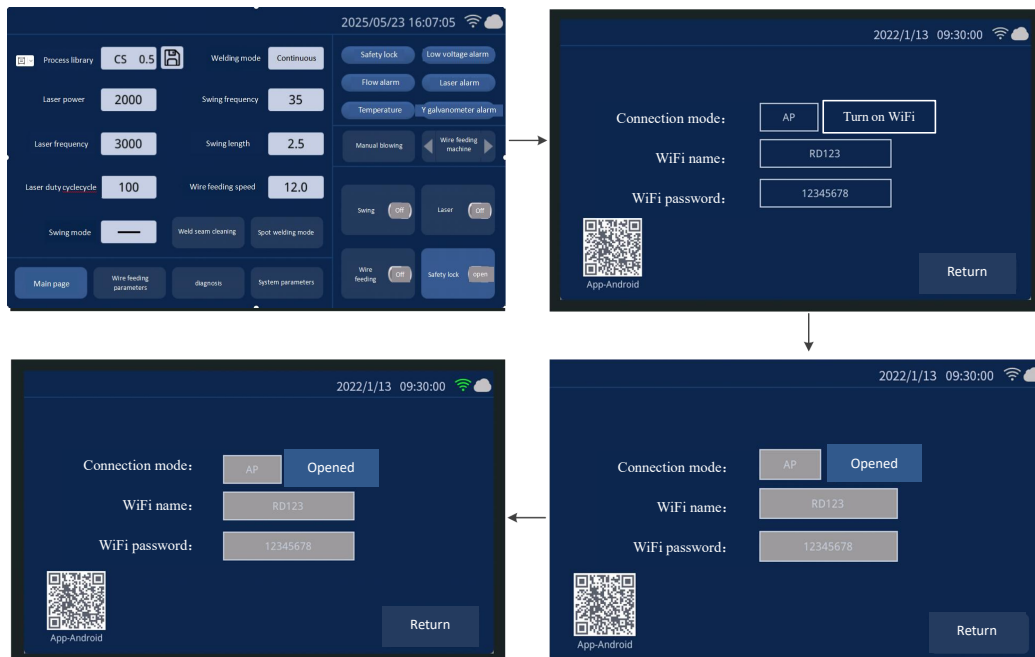

APP Settings:

- Click the icon on your mobile phone to launch the APP.
- The device connection status in the upper left corner of the motor enters the < Device Management > page.
- Select the direct connection of the device, enter the phone Settings page to set up the WIFI connection, and connect to the WIFI hotspot of the control card.
- After the connection is completed, you can enter the APP to check that the mobile APP has been connected to the device.

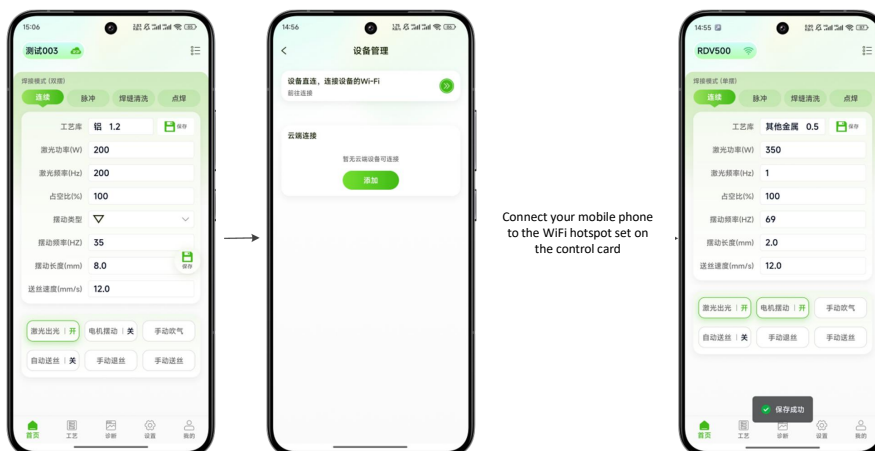

Shenzhen RelFar Intelligent Technology Co., Ltd.

12.2.3 STA mode connection

Board card Settings:

- Click the upper right corner of the touch screen to configure the WIFI hotspot and enter the WIFI configuration page.
- Set the connection mode to STA and connect to an external WIFI. If the WIFI is turned on, you need to first click the < Turned On > button to turn off the WIFI. When the WIFI icon goes off, you will enter the configurable WIFI setting state.
- After the configuration is completed, click the < Turn on WIFI> button, and the system will connect to an external WIFI.
- After the WIFI connection is completed, the WIFI configuration mode will be turned off, the remote icon will light up, and the device will be in an online state.

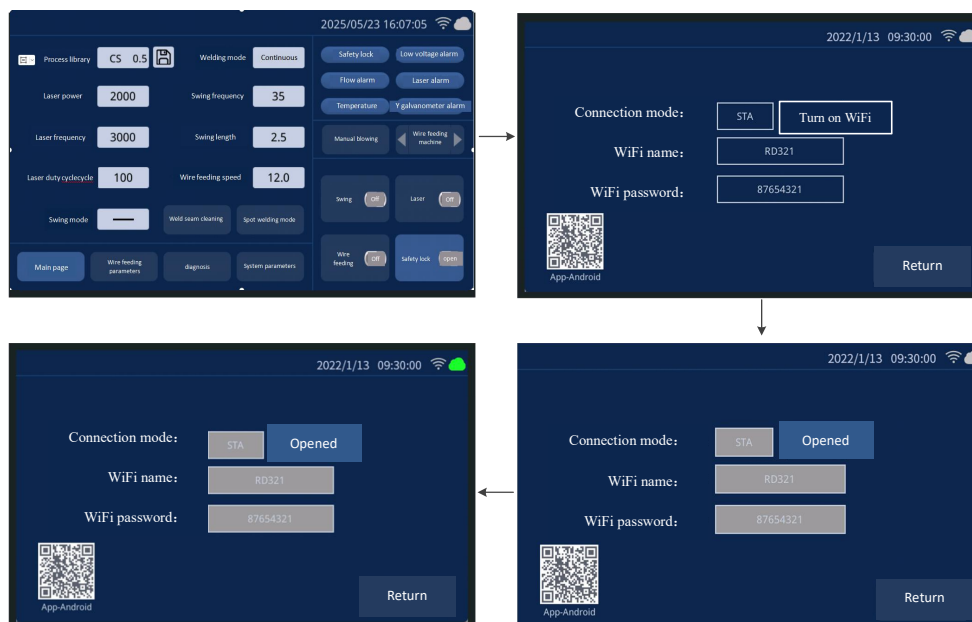

APP Settings:

Click the icon on your mobile phone to launch the APP.

The device connection status in the upper left corner of the motor enters the < Device Management > page.

You can view the added cloud devices on the device management page. The highlighted cloud logo indicates that the device is online, while the grayish-white status indicates that it is offline.

After selecting the online device, click "Connect" to complete the device connection.

Shenzhen RelFar Intelligent Technology Co., Ltd.



Note: The STA mode requires users to register an account and then add the device serial number to their personal account before remote management can be carried out.

12.3 APP download method

Android:



https://mantisolo.com/versionQrCode.html?qrform=6a7a13d4f48d72e6e02b0b12af8e3bc13&company_code=003&platform=APP

Apple: Search for "RDWelder" in the App store

12.4 APP function

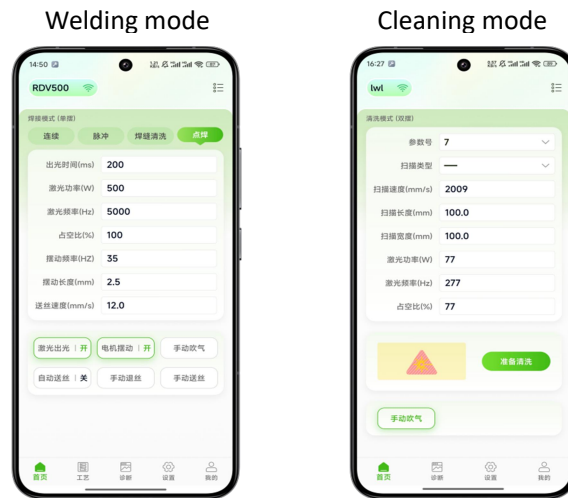

The RDWelder mobile APP supports single pendulum welding, single pendulum cleaning, double pendulum welding and double pendulum cleaning. After the APP is connected to the board card, it can automatically adapt to the current processing mode of the control card.

Welding mode:

[Home Page] : Supports management of process parameters, processing status, blowing adjustment, and wire feeding control. The entry to < Technology Center > is located in the upper right corner.

【 Process 】 : Welding process library, where users can manage process parameters.

【 Diagnosis 】 : Manage the status of the equipment, support the query of alarm records, and enable central correction.

【 Settings 】 : Go to the parameter setting page to manage ordinary setting parameters. You can enter the authorization management. After entering the password, you can manage advanced parameters.

[My] : Personal user page for managing personal information.

Cleaning mode:

[Home Page] : Supports management of process parameters, processing status, and blowing adjustment. The entry to < Technology Center > is located in the upper right corner.

【 Diagnosis 】 : Manage the status of the equipment, support the query of alarm records, and enable central correction.

【 Settings 】 : Go to the parameter setting page to manage ordinary setting parameters. You can enter the authorization management. After entering the password, you can manage advanced parameters.

[My] : Personal user page for managing personal information. Style.

Chapter 13 Introduction to Wisdom Cloud

13.1 Function Introduction

The smart cloud system enables devices to access the Internet, allowing users to view the device status on the web page for remote management.

13.2 Smart Cloud Login

By visiting <https://fiot.chanelink.com/> address, see page client login page, the following figure, the user account login, new user registration, password can be recovered, and so on.

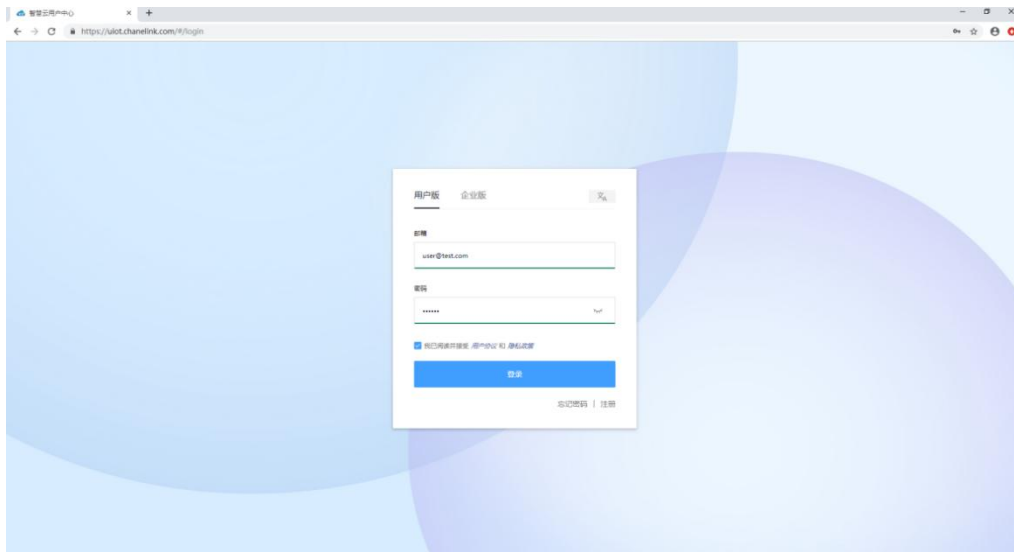

13.3 User Center

After successful login, you will be redirected to the home page of the User Center, as shown in the following figure. Users can view the added application functions, such as device management, My Profile, remote assistance, technical support, etc.

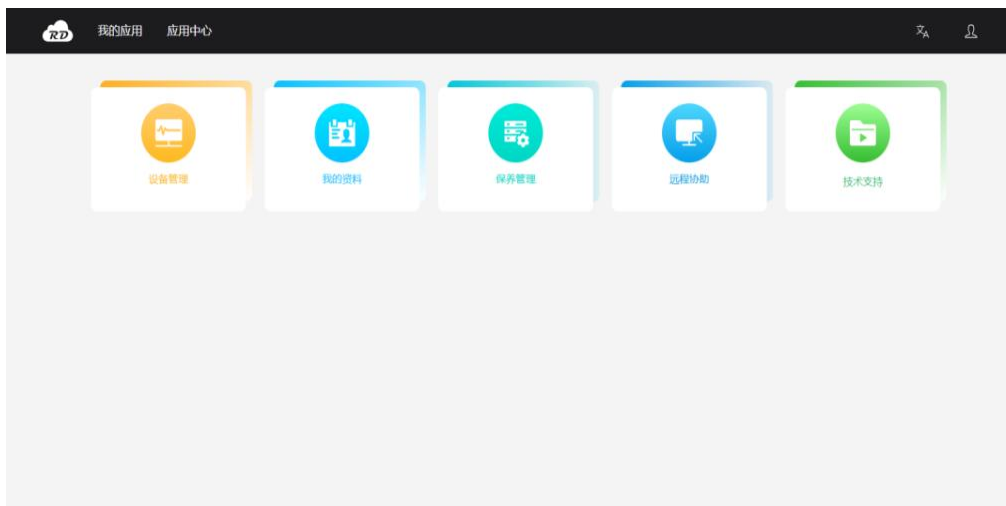

Shenzhen RelFar Intelligent Technology Co., Ltd.

My application, as seen in the above picture, the one added by this user, can manage the added applications.

Application Center, where applications can be added.

Personal information, click this button to go to my profile, you can modify person information.

Log out. Click this button to exit to the login page.

13.4 Equipment Management

In "My Applications", click on "Device Management" to jump to the "Device Management" page, as shown in the following figure.

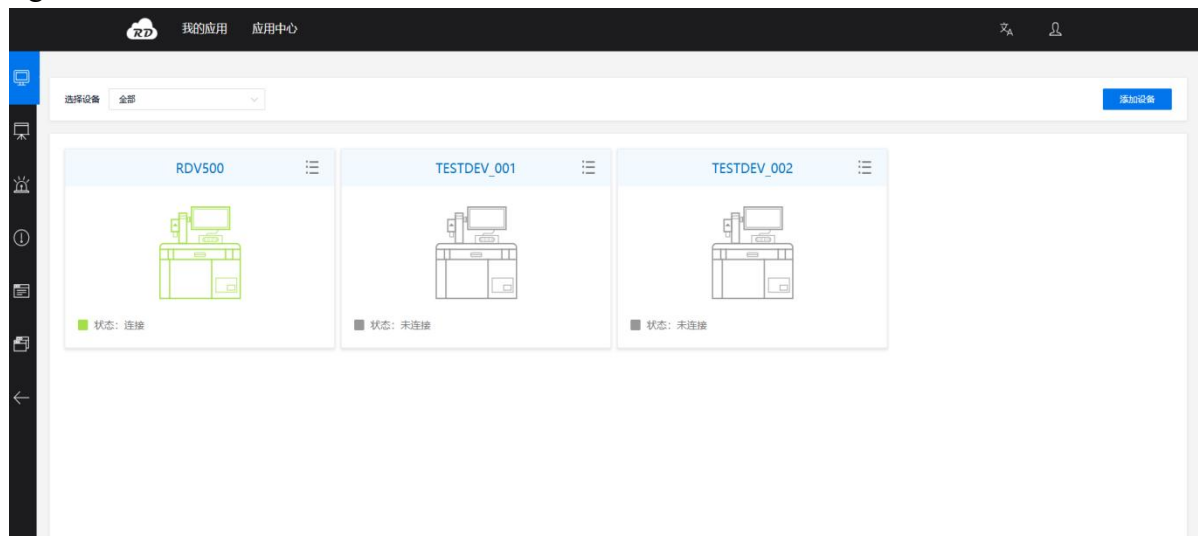

The left side is the menu bar, which opens the device monitoring page by default.

The device nickname entered when adding the device.

The connection status of this device indicates whether the device is connected to the Internet.

Equipment operation list (expands when the mouse hovers).

The equipment operation list has the functions of editing, detailing and unbinding.

The device can be edited, unbound and details viewed.

The "Add Device" button allows you to add devices to your personal account.

13.5 Remote assistance

In "My Apps", click on "Remote Assistance" to be redirected to the Remote assistance page, as shown in the following figure.

Shenzhen RelFar Intelligent Technology Co., Ltd.

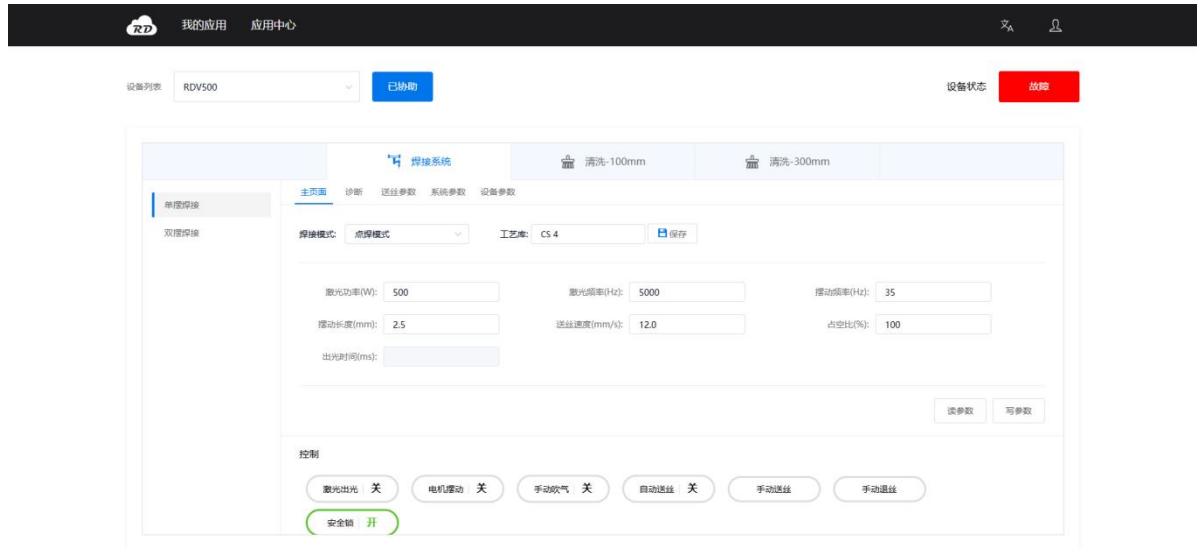

You can view the devices under the added personal account in the device list. After confirming the need for a remote assistance device, a remote connection can be made to check the device status and manage parameter configuration.

13.6 Technology Center

In "My Applications", click on "Technical Support" to be redirected to the technical support page, as shown in the following figure.

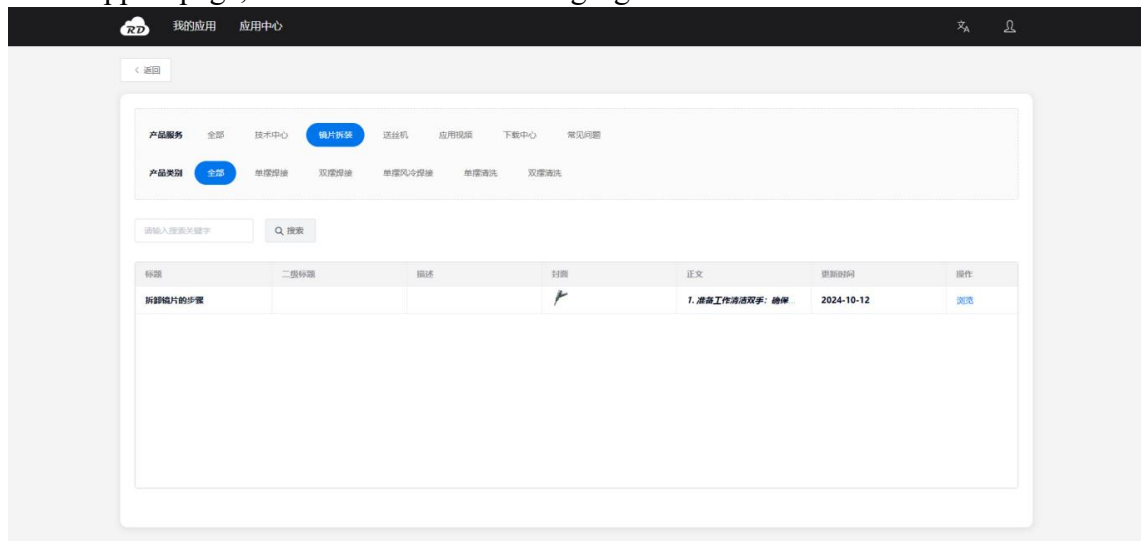

On the technical center page, you can query various product information, including downloading instruction manuals and viewing application videos in the download center.

Thanks for using our products!

Web: www.relfar.com

Tel: 0755-23143635

Address: 2F, Building 7, Jiuyang Industrial Park, 57 Hexiu West Road, Baoan District, Shenzhen, Guangdong Province