

Be sure to read the manual before using the system

- This manual is the user manual of double-swing handheld laser welding system
- Read the manual carefully first to ensure the correct electrical connection

BWT20

Qilin Wobble Handheld Laser Welding Head

V11 controller + BWT20 welding head

Shenzhen Qilin Laser Application Technology Co., Ltd.

Address: Building 8, Fanmao Industrial Zone, Shuiyin Road,

Gongming Street, Guangming New District, Shenzhen

Tel: 0755-27999931

Address: www.qilinlaser.com

Copyright Statement

Shenzhen Qilin Laser Application Technology Co., LTD. (hereinafter referred to as Qilin Laser) reserves all powers.

—Qilin Laser has the patent copyright and intellectual property rights of this product. Without the authorization and permission of Qilin Laser, it shall not directly or indirectly copy, manufacture, process or use the product and its relevant parts, otherwise Qilin Laser will be investigated for relevant legal liabilities according to law.

—Qilin Laser retains the right to modify the documents such as products and product specifications in this manual without notice, while retaining the right to modify any documentation attached with this product.

—Users should read the manual carefully when using the products described in this article. Qilin Laser does not bear the direct, indirect, special, incidental or corresponding losses or liabilities caused by the improper use of this manual or this product. Qilin Laser does not bear the following direct or indirect liabilities or losses:

- Users use this manual or this product improperly
- The loss caused by the user for failing to follow the relevant safety operating procedures

—The loss caused by natural forces makes the machine in movement dangerous, the user is responsible to design an effective error handling and safety protection mechanism in the machine, and Qilin laser has no obligation or responsibility to be responsible for the incidental or corresponding losses caused thereby.

Certification statement

The CE Certification Statement

This product has passed the EU CE (Communate Europpene) safety certification, has passed the corresponding conformity assessment procedures and the manufacturer's conformity declaration, and comply with the relevant EU directives.

ROHS, Certification Statement

This product has passed the EU legislation on restricting the use of certain harmful components in electronic and electrical equipment (Restriction of Hazardous Substances) safety certification, in accordance with the relevant EU environmental regulations.

The FCC Certification Statement

This product has passed the US Federal Communications Commission (Federal Communications Commission) safety certification and complies with the relevant safety regulations of American electronic products.

Security information

Please use the system and operate safely. Use some signs or text to remind you of dangerous matters and some important information.



DANGER:

Represents a serious danger. In the process of use, if improper operation or wrong use, may lead to serious injury or even death, please do not operate easily, until ensure that the operation method is correct and correct use of use.



WARNING:

It indicates a danger. In the process of use, if improper operation or wrong use, may cause personnel injury, please do not operate easily, until to ensure that the operation method is correct and use the correct.



CAUTION:

Represents a potential risk of the product. During use, if the use method is wrong or improper operation, the product or some parts may be damaged. Please users and related personnel do not operate easily, until to ensure that the operation method is correct and correct before use.

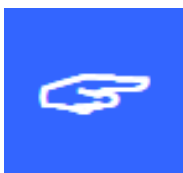

IMPORTANT:

Represents important information to note during product use. Please do not ignore this information, these, the information will provide effective operational help.



This label indicates that the laser radiation is generally attached to the output laser products. Be careful of the laser and safety when using such equipment.

Receiving & Unpacking & Inspection

The product uses shock-proof soft packaging. If the package has any external damage traces, please check the equipment damage and inform the carrier and the carrier of the damage in written documents.

Important:



After receiving the product, please check whether the outer package is intact, and check whether the product is complete and all parts are intact after unpacking. If any damage is found, please contact Qilin immediately.

Remove all goods from the package and keep the packaging materials and wiring parts. Please be careful that the goods are safe when dismantling the package and After removing the goods, please check if the parts are complete and intact. If missing parts are found or damaged, please contact Qilin Laser immediately. If any obvious damage to the equipment is found, do not install or debug the equipment. The delivery list of the user manual is shown in the following table: (As the product is constantly updated, the shipping list may be adjusted too.)

	Component	Qty	Remarks
1	The BWT20 handheld welding head	1	
2	V11 controller	1	
3	BWT16 wire feeder	1	Optional
4	7-inch LCD screen (HMI)	1	
5	7-inch display display cable	1	
6	±15V power supply	1	
7	±15V power cable	1	
8	24V power cord	1	
9	Urgent stop trigger line	1	
10	7.5m DB15 cable set	1	
11	Safety clip (with clip)	1	
12	Set of wire protection box	1	
13	Copper mouth and wire clip box	1	
14	laser goggles	1	
15	Protect the lens	5	

catalogue

Chapter 1. Overview	1
1.1 BWT 20 Qilin double swing handheld laser welding system introduction...	2
1.2 Touch-screen installation dimensions	2
1.2.1 Touch-screen installation dimensions.....	2
1.2.2 Control box mounting dimensions.....	
1.2.3 Installation size of the 15V switch power supply.....	3
Chapter 2. System Wiring	4
2.1 Control box wiring	5
2.2 Structural diagram of the gun and pipe and pipe connections	6
2.3 Power joggle	8
2.4 human-computer interface HMI	10
2.5 Laser-decoding interface	10
2.6 Double-swing handheld laser welding head interface	11
2.7 Urgent stop trigger line	11
2.8 Fan interface introduction.....	11
2.9 Control interface of wire feeder	12
2.10 Description of the wire delivery machine keys	13
2.11 Laser control interface	14
2.12 Gas control, air pressure detection interface.....	15
2.13 Dial switch	16
Chapter 3. Introduction to MI HMI	17
3.1 Introduction to MI HMI function and operation	
3.1.1 Introduction of main interface function and operation	18
3.1.2 Introduction of setting up interface function and operation	18
3.1.3 Introduction of the small display screen of the gun head	21
Chapter 4. Notes	23
Qilin laser technical support and service scope	24

Chapter 1

Summary

**The main contents
of this chapter
are follows:**

- Introduction of Wobble handheld laser welding system
- Product installation dimension drawing

Introduction to the handheld laser welding system

Qilin wobble handheld laser welding system is a control system developed by Qilin laser and specially used for optical fiber laser welding. Double vibration mirror motor control, there are seven swing modes: dot, line, circle, ellipse, triangle, eight characters, semicircle. High-speed digital motor swing design, circulating water design, fast cooling optical road cavity, ergonomic design, high-end chip, a variety of safety protection measures and other functions and features.

1.2 Installation size of the touch screen

1.21 Touch-screen installation dimensions are shown in the figure below:

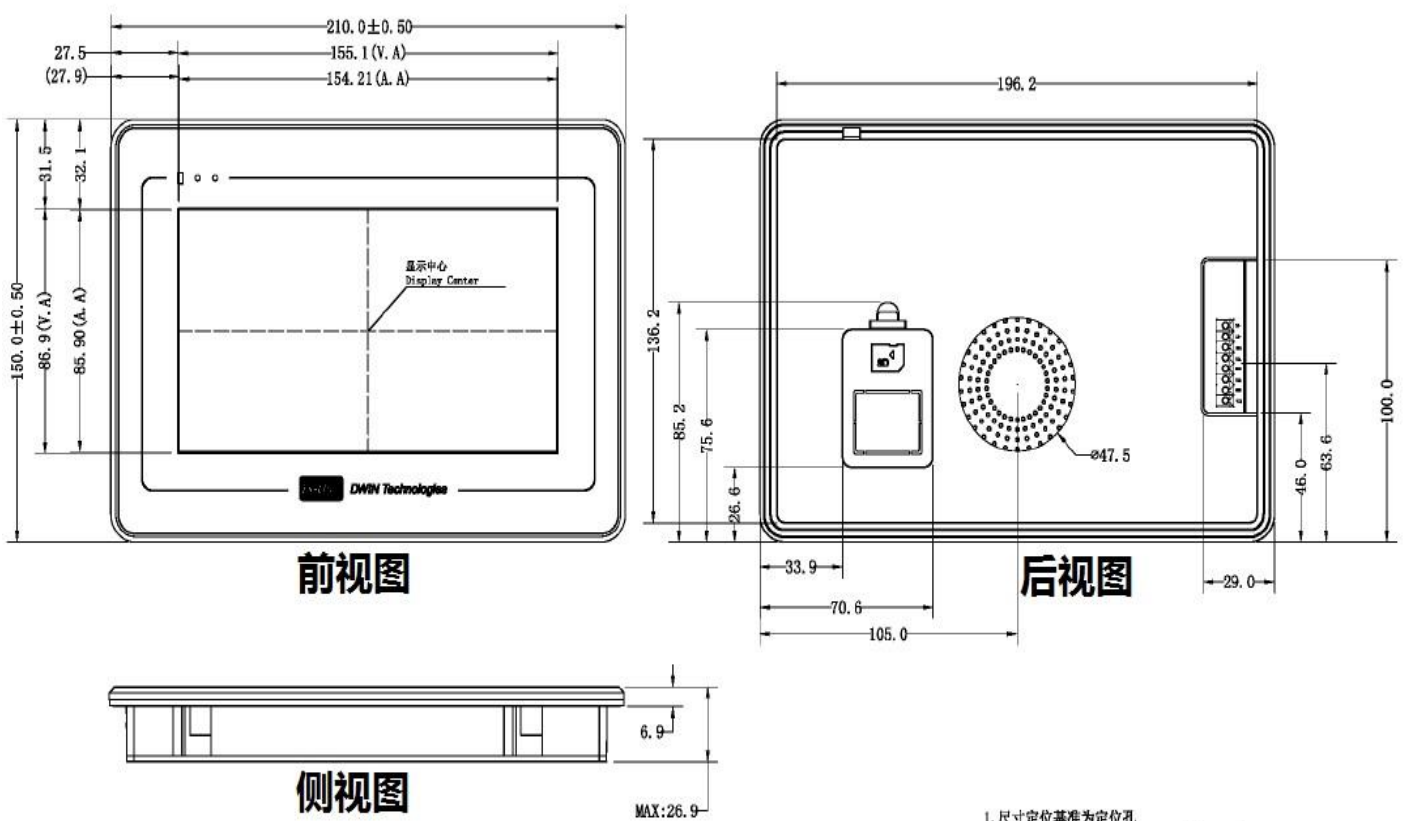

1. 尺寸定位基准为定位孔
Location hole is used as position reference.
 2. 未标注公差为 $\pm 0.3\text{mm}$
Unmarked Tolerance is $\pm 0.3\text{mm}$
- 注: 虚线标注为有效显示区域
Active area is marked in Dash lines

1.2.2 The installation size of the control box is shown in the figure below

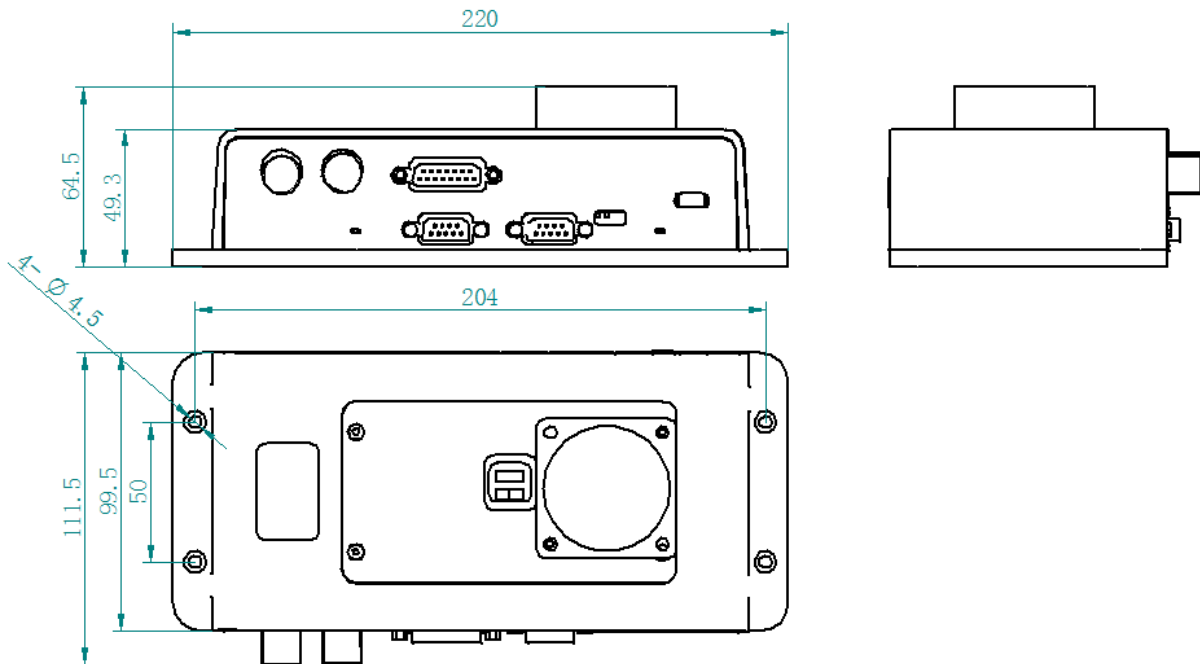

1.2.3 The installation size of the 15 V switch power supply is shown in the following figure

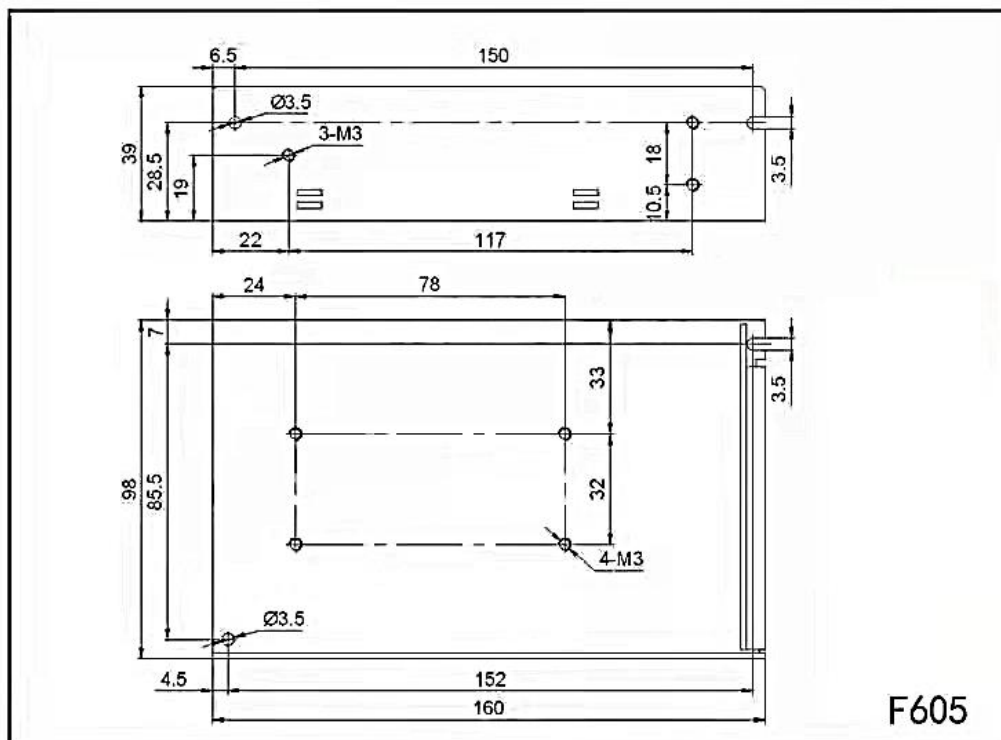

Chapter 2

System wiring

**The main contents
of this chapter
are follows:**

- Control box wiring
- Structural diagram of the gun and pipe and pipe connections
- Power interface HMI
- Laser-decoding interface
- Double-swing handheld laser welding head interface
- Urgent stop trigger line
- Fan interface introduction
- Control interface of wire feeder
- Description of wire delivery keys
- Laser control interface
- Gas control, air pressure detection interface
- Alarm signal interface
- Warning lamp interface
- Dial switch

2.1 Control box wiring

The following diagram shows the wiring diagram of the whole system, the system wiring can refer to the schematic diagram, please refer to the relevant sections for detailed interface definition.

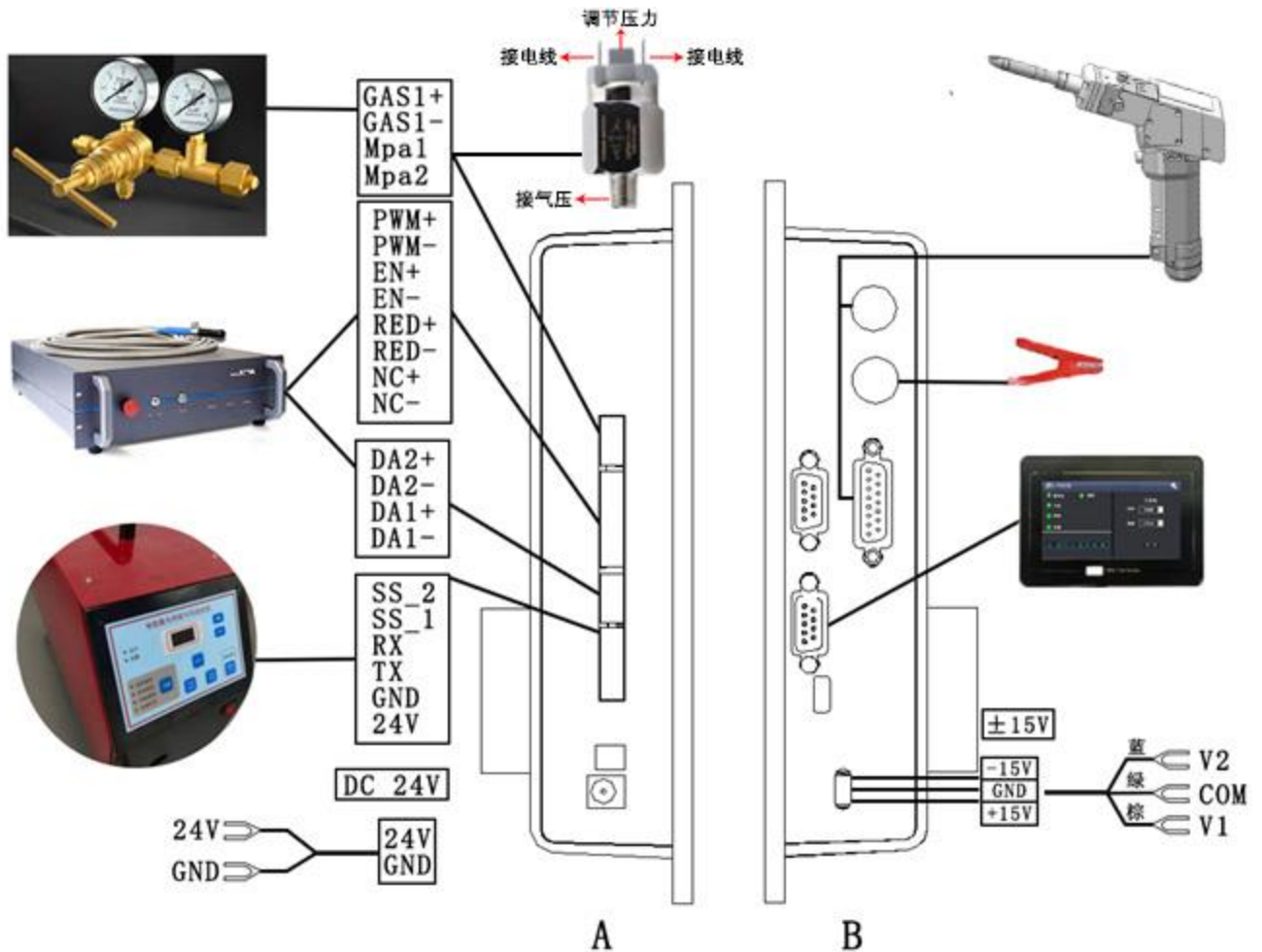
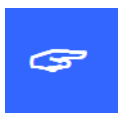

Figure 2.1 Schematic diagram of the system wiring



important:

Do not access other lines in the part not specified in the control box.

2.2 Structure diagram of the gun and trachea and water pipe interface

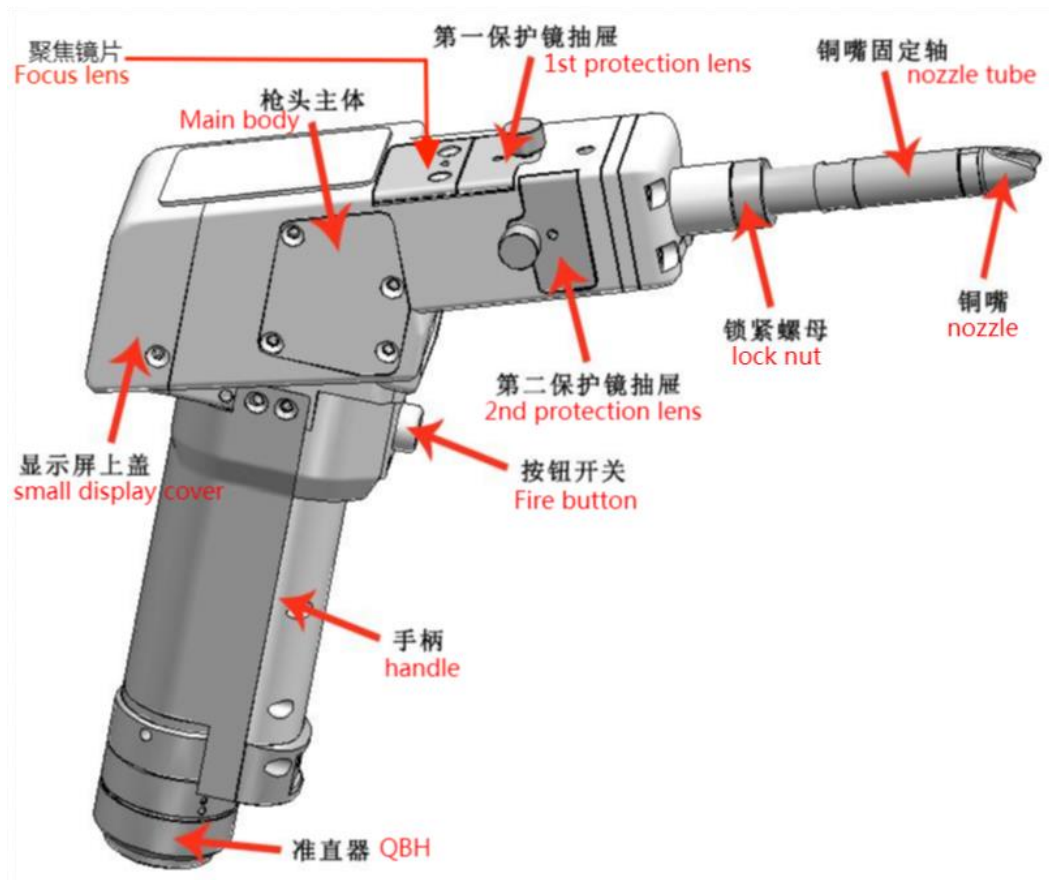

Figure 2.21 Schematic schematic diagram of the gun

Technical parameters	
Interface type	QBH
Power Range	2000W
Laser Wavelength	1064-1080
Wobble Width	0.2-5.0 mm
Protective lens	D20X2
Collimating length	50 (D20F50*3.5)
Focal length	150 (D20F150*3)
Reflect lens	22.5*17*3
Cooling Way	Water/Air
Weight	0.98 kg
Max air pressure	0.6Mpa
Adjustable vertical focus range	±3mm
Working Mode	



Figure 2.22 Schematic diagram of gas pipe and water pipe interface

Water pipe: water pipe in and out, forming a closed water circulation.

Gas pipe: single joint, gas output.

DB15 interface: the connector connecting the control system and the gun head communication function.

Samsung aviation plug: the connector connecting the conduction and trigger signal.

2.3 Power interface



Figure 2.31 Schematic diagram of the Power interface



The + 15V interface is the interface that provides power for the motor drive inside the control box, the voltage is plus or minus 15V ($\pm 15V$)

Table 2.31 shows the definition of the + 15V interface power cord

Table 2.31

Pin	Signal	Definition	Description
1	V1	power input +15V	+ 15 External power supply input, external power supply output Current is bigger than 2A
2	COM	GND	Power ground
3	V2	power input -15V	-15 External power supply input, external power supply output Current is greater than 2A

DC24V interface is the interface providing power for internal control system of control box, the voltage is DC 24V (DC24V).



Figure 2.32 shows the schematic diagram of the POWER 2 power cord



Table 2.32 shows the definition of the \pm 24V interface power cord

Table 2.32

1	24V	power input	+ 24V external, power supply input, power supply output power requirements: above 200W, means the output current is bigger than 8A (Power supply requires for feeder)
2	COM	Power reference ground	Power ground

2.4 HMI

The HMI interface is a DB9 black plug through which the motherboard supplies and communicates to the HMI.

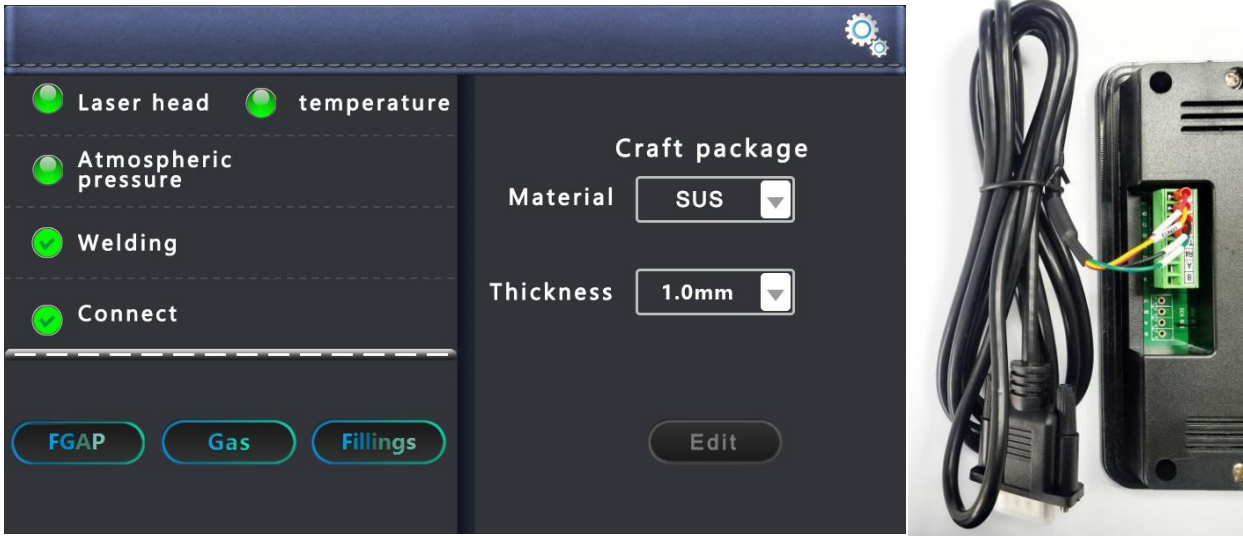

Figure 2.4 Schematic diagram of the HMI

Table 2.4 is the definition of the HMI interface.

Table 2.4

1	24V	Power supply output, 500mA	HMI supply electricity
2	GND	Power supply output place	Power reference
3	TXD	The sender of the HMI	Serial port communication with the TXD signal
4	RXD	Receiver end of the HMI	Serial port communication with the RXD signal

2.5 Laser device decoding interface



The LASER RS232 interface is a board card and a laser communication port.

1	DB9	Laser and board card communication interface	Communication with the laser source and unlock it

2.6 Double-swing handheld laser welding head interface

The motherboard provides a mirror interface, compatible with the universal digital mirror interface on the market.

Table 2.6 shows the definition of the vibration scope interface.

Table 2.6

1	DB15	Vibrator mirror & OLED interface	Control wire for communication with the handheld welding head

2.7 Emergency stop trigger line

The control box provides a special security trigger signal line interface, which can provide a security guarantee for the operation.

Table 2.7 defines the safety clip interface.

Table 2.7

1	CF	Trigger, signal	The light condition is reached when triggered
2	DT	Guide communication number	The light condition is achieved only during conduction

2.8 Introduction of the fan interface

The control box provides a dedicated 24V fan port interface position, independent port, not easy to insert wrong.



Figure 2.8 Schematic diagram of the fan interface

2.9 Control interface of wire feeder

The control box provides a special communication interface for controlling the wire transmitter, and the 24V power supply is directly connected to the power input of the control box and can be provided 3A Current.

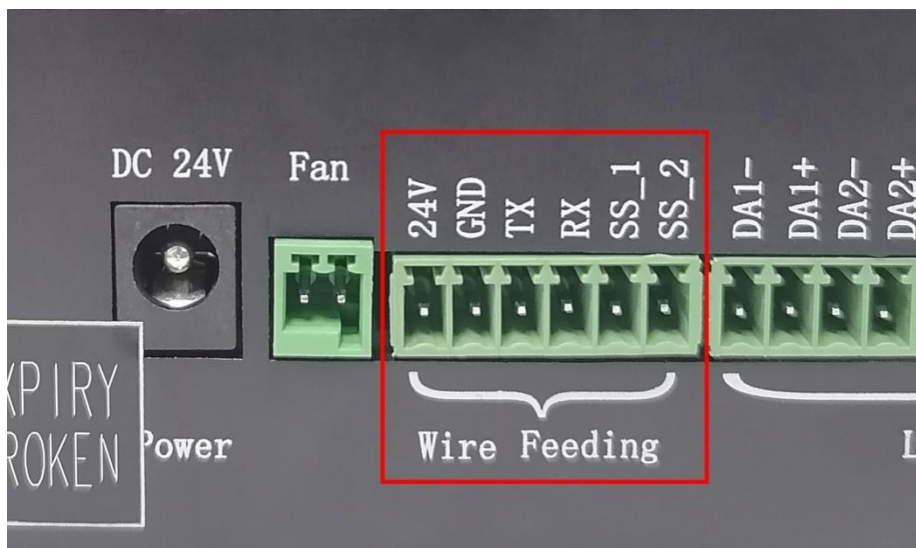

Figure 2.9 Schematic diagram of the control interface of the wire feeder

Table 2.9 defines the wire feeder control interface.

Table 2.9

1	24V	Power supply output end of the wire feeder	Silk feeder 24V + power interface
2	GND	GND	GND
3	TX	Silk delivery machine and board card communication port	The wire transmitter communicates the TX signal with the control system
4	RX	Silk delivery machine and board card communication port	The wire transmitter communicates the RX signal with the control system
5	SS_1	Wfeeder trigger signal 1	Automatic discharge when short circuit SS_1, SS_2
6	SS_2	Wfeeder trigger signal 2	Automatic discharge when short circuit SS_1, SS_2

2.10 Button description of the wire delivery machine

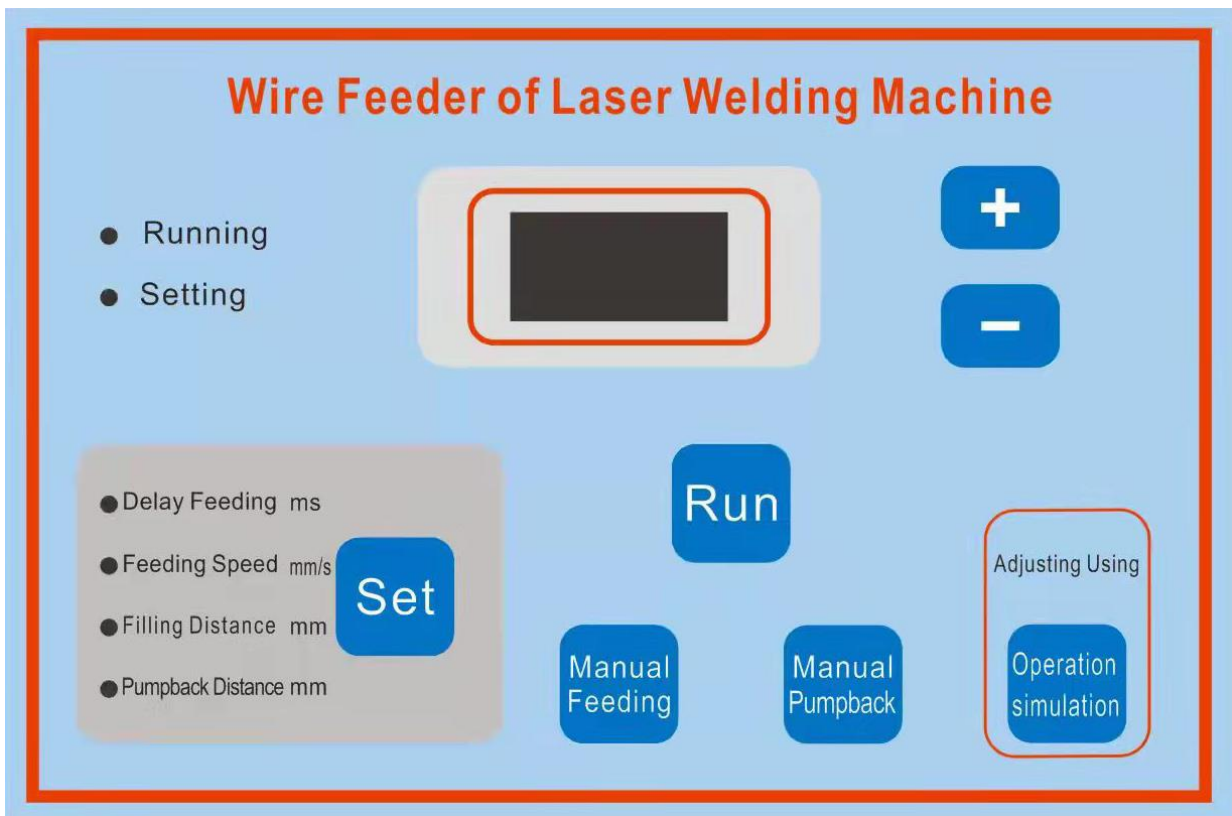

Figure 2.10 Description diagram of wire feeder keys

Feeder button description:

Icons	Description
	Select below 4 functions
	Delay feeding: After setting, the light output is delayed first and then the wire is sent.
	Feeding speed: Running speed of the wire delivery wheel.
	Filling distance: compensate the distance.
	Pumpback distance: After the wire supply stops, the wire pulls the back distance.
	Data up
	Data down
	Save the parameters after setting them.
	Click the manual wire supply, and the wire supply wheel runs the wire supply at the maximum speed.
	Click the manual pumping wheel to return the wire at the highest speed.
	After the wire speed is set, click simulation operation is the set wire speed.

2.11 Laser control interface

The laser interface is an 8PIN green terminal + 4PIN green terminal.

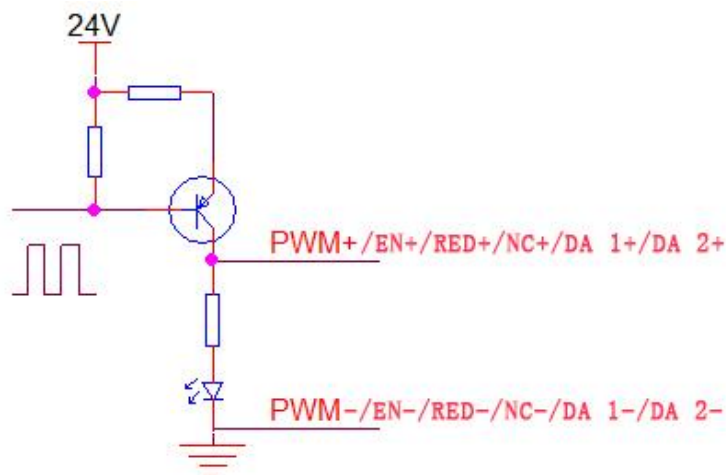

Figure 2.11 Schematic diagram of the laser control interface

Table 2.11 is the definition of the laser interface.

Table 2.11

1	PWM+	Laser-modulated signal +	Duty cycle is 1% -99% adjustable, 24V and 5V switchable
2	PWM-	Laser Modulated signal-	Reference place for connecting to the power source
3	EN+	Laser enabling signal +	Control laser light signal, high level effective, 24V and 5V switchable
4	EN-	Laser-enabling signal-	Reference place for connecting to the power source
5	RED+	Laser red light signal	Laser red light control (not connected)
6	RED-	GND	Reference place for connecting to the power source
7	NC+	The laser enables the backup ports	Laser 24V spare port
8	NC-	Laser backup port ground	Reference place for connecting to the power source
9	DA 1+	Analog voltage output +	For laser peak power regulation, 0-10V and 0-4V analog voltages are optional
10	DA 1-	Analog voltage output-	Reference place for connecting to the power source
11	DA 2+	Analog voltage output	For proportional valve adjustment, 0-10V analog voltage,
12	DA 2-	GND	Reference place for connecting to the power source

2.12 Gas control and air pressure detection interface

The control box provides a dedicated IO interface, all output IO are OC output can directly drive the relay, the maximum current can reach to 500mA, the wiring diagram is shown below.



Figure 2.121 Schematic diagram of the gas control interface

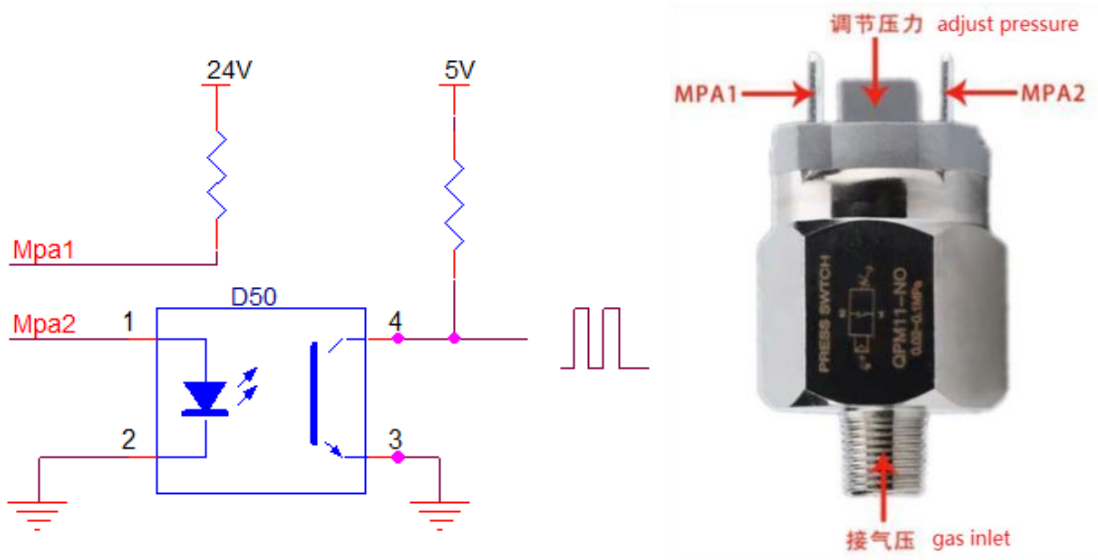

Figure 2.122 Schematic diagram of the air pressure detection interface

Table 2.12 is the definition of the gas control interface

Table 2.12

Terminal	Label	Description	Connection
1	CAS 1+	For protect gas blowing control positive electrode	Air valve + connecting card GAS1 +
2	CAS 1-	Use to protect the gas to blow the gas to control the negative electrode	Air valve-connecting card GAS1-
3	Mpa1	For detect air pressure alarm	Air pressure alarm + connecting plate Mpa1
4	Mpa2	For detect air pressure alarm	Air pressure alarm + connecting plate Mpa2

2.13, Dialing Switch for IPG

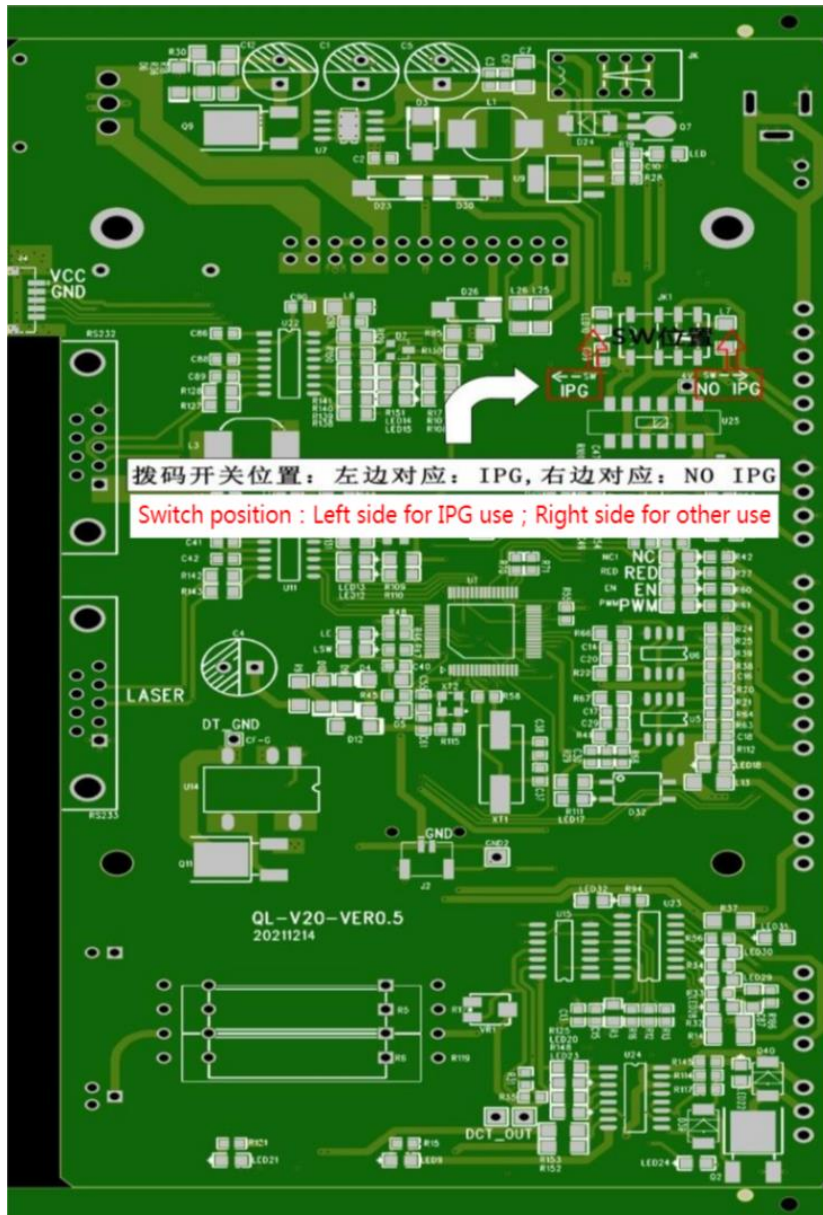

Figure 2.13 Schematic diagram of the dial code switch

1	IPG	Laser control signal	PWM, EN, RED, NC outputs of 5V Power adjustment: 0-4V analog voltage with adjustable section
2	NO IPG	Laser control signal	PWM, EN, RED, NC outputs of 24V Power adjustment: analog voltage adjustable section 0-10V

Chapter 3.

Human-machine Interface -HMI

**The main contents
of this chapter
are follows:**

- Introduction of the main interface function and operation
- Set up the interface function and the operation introduction
- Gun head small display screen function introduction

3.1 Introduction to HMI function and operation

3.1.1 Introduction of main interface function and operation

The operating panel of Qilin wobble handheld laser welding system adopts a 7-inch configuration capacitive touch screen, which is dignified, generous and easy to operate. The relevant parameters of the laser and the laser swing head can be set respectively, and the light mode can be controlled. At the same time, the process parameters stored inside the machine can be selected on the main interface. At the same time, these art parameters can be adjusted and saved to facilitate the subsequent direct call, and the art package can also be customized.

3.1.2 Setting of interface and operation introduction

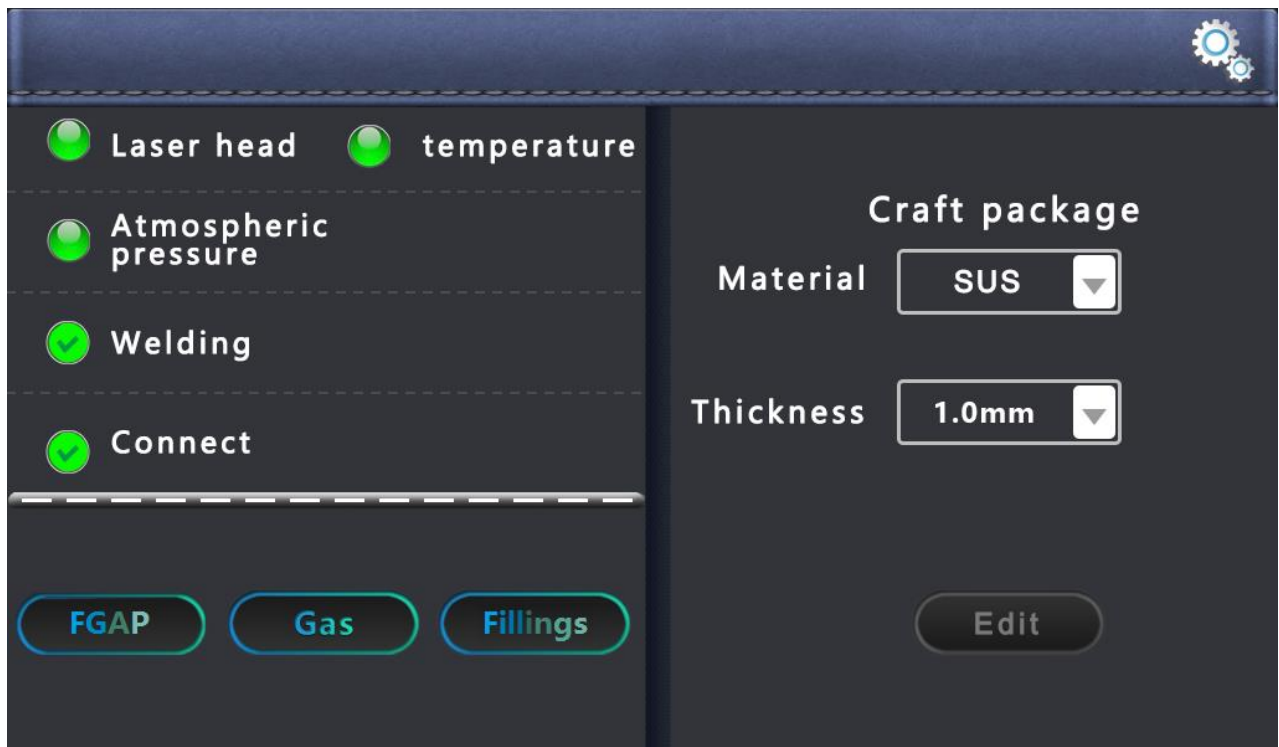

Main interface pic

Alarm signal lamps: Being the monitor and alarm the temperature of laser head, air pressure, welding gun, conduction and handle. Full alarm status is displayed synchronously on the main screen and alarm light to remind users and quickly troubleshoot problems.

FGAP: Laser comes out only if FGAP button is on.

Gas: When the Gas button is on, the air valve port will output 24V voltage, and the gas will automatically provide gas without opening it during welding.

Fillings: The wire feeder works when fires when the Fillings button is on; When it off, the wire feeder won't work.

Process Package:

There are 4 common use materials, definitions as follows:

SUS: stainless steel // **CS:** carbon steel

SECC: Galvanized plate // **AL:** aluminum

The number behind materials is thickness, for example:

SUS/1.0 means 1.0mm Stainless Steel

Custom (UDC): can edit parameters, facilitate customers to retrieve the process for welding.

Other (OTS): internal manufacturer special process editing, can transfer special process for special material welding.

Click "Edit" button to enter the main editing interface.

[Edit the main interface schematic diagram](#)

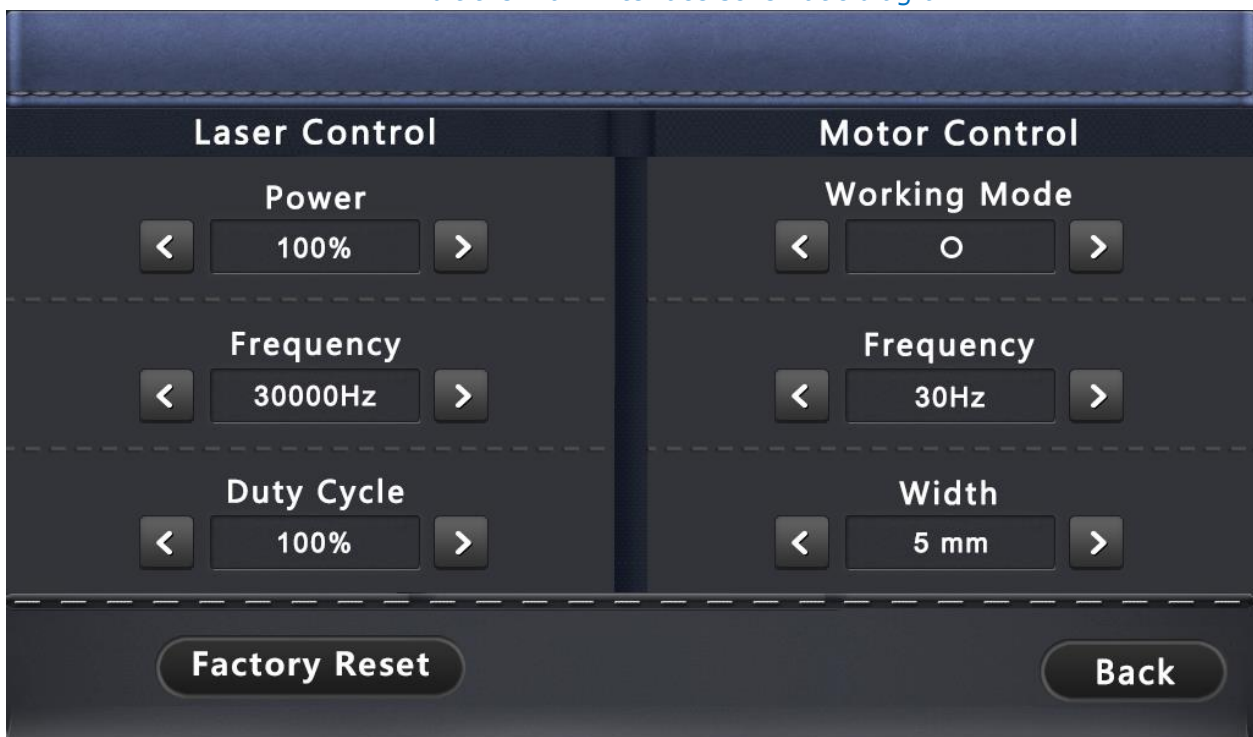

Edit: no need to click to confirm, after changing parameters, directly use parameters.

Laser control:

Power: Set the peak power of the laser at welding.

PWM frequency: Set the frequency of the laser PWM modulation signal.

Duty cycle: Set the pulse width of the laser NE enabling signal.

Laser head control:

Mode: Set the mode of the motor swing.

Frequency: Set the speed of the motor's swing.

Width: Set the width of the motor swing.

Factory Reset: after entering the edit page, reset the single page parameters.

Press "" on the main interface to enter the setup interface as shown in the figure below



Parameter Settings

Ramp Control

Slow rise time: The laser power slowly reaches the peak power within the set slow rise time.

Slow fall time: After the laser power is off, the laser energy is slowly off to 0.

Off delay: After turning off the laser, there is also a full power output during the setting time to optimize the wire breaking function.

Gas Control:

Advance: The time setting of gas comes out first before laser comes out.

Delay: The time setting of gas comes out after laser comes out.

Proportion valve: if the equipment has a scale valve to control the gas strength, then the percentage of protection gas can be controlled by this function.

Setting position of red light

Red light offset setting: when the red light is not in the center of the nozzle, it can be adjusted by adjusting X and Y coordinates.

Start correction: zero the coordinates of X and Y.

Clear correction: Clear the previous correction.

Setting for SN and languages

S/N: the serial no. of welding head and controller.

Version: Firmware version.

Available life (days): Available using time, all functions fail after expiration.
(Automatic reminder when it less than 7 days)

License: Password to unlock the products.

Languages: English, Russian, Korean, Vietnamese, Japanese, Chinese.

3.1.3 Introduction of the small display screen of the gun head



Icons	Description
	The material and thickness corresponding to the craft package which being used.
	Feeding speed.
	The temperature of the handheld welding head.
	FGAP
	Feeding function on/off.

Craft Package Parameters Ref:

No.	1500W Laser control				Laser head control		
	Material and thickness	Power	Freq.	Duty cycle	Pattern	Freq.	Width
1	Stainless steel 1.0	30%	3000Hz	100%	○	10hz	1.6mm
	Stainless steel 2.0	60%	3000Hz	100%	△	10hz	2.6mm
	Stainless steel 3.0	90%	3000Hz	100%	⊗	10hz	3mm
2	Carbon steel 1.0	30%	3000Hz	100%	○	10hz	1.6mm
	Carbon steel 2.0	60%	3000Hz	100%	△	10hz	2.6mm
	Carbon steel 3.0	85%	3000Hz	100%	⊗	10hz	3mm
3	Galvanized plate 1.0	35%	3000Hz	100%	○	16hz	1.6mm
	Galvanized plate 2.0	65%	3000Hz	100%	△	16hz	2.6mm
	Galvanized plate 3.0	85%	3000Hz	100%	⊗	16hz	3mm
4	Aluminum plate 1.0	40%	3000Hz	100%	○	10hz	1.6mm
	Aluminum board 2.0	70%	3000Hz	100%	△	8hz	2.6mm
	Aluminum plate 3.0	85%	3000Hz	100%	⊗	8hz	3mm

The above parameters are provided for reference only

Precautions for using a laser welding system

1. Laser welding machine includes laser source, chiller, laser welding system, laser welding head multiple control modules. In order to avoid interference, to ensure that the argon arc welding machine and related equipment with large interference, to ensure a safe distance of more than 5 meters. Ensure that the laser welding machine has independent space when conditions permit.
2. In order to reduce the equipment leakage or static electricity, to ensure that the light double pendulum industrial welding head equipment uses effective ground wire.
3. Please repeatedly confirm whether the sleeve joint is normally connected and locked, which can be wrapped with insulation tape.
4. Check whether the laser head and the optical fiber are locked and connected. After confirming the normal condition, use the tape to ensure that the dust does not enter the laser head cavity.
5. Check whether there is water seepage in the cavity. There are many waterways in the cavity. The screws should not be loosened without professional training to prevent water droplets from entering the cavity.
6. Check whether the protective lens drawer is normal, ensure that the sealing ring is normal and effective, ensure that the protective lens wipes the external stains of the laser lens, at least 5 times, and ensure that the lens environment is dust and wind.
7. The laser head is complex. To avoid short circuit, stay away from the water source and ensure that no liquid can be sprayed on the laser head.
8. Laser head refuse to use strong wind to blow and clean the laser head, can only use alcohol and dust-free cloth to wipe.
9. A digital motor is installed inside the laser head, which must be taken and put gently when used to prevent motor failure.
10. If the laser head is not used, please use the system gas for many times to discharge the dust, remove the copper nozzle, seal with sealant belt, and install the copper nozzle to blow gas more than 2 times before use.
11. Continuous interruption of power supply will cause damage to the welding control system.

If the external wire transmitter, 24V power supply should provide 200W (supply voltage 24V, output current equal to or greater than 8A)!

12. The external safety lock is 24V high level, do not short connect with the aviation plug GND shell of the system cable, or do not pay attention to collide with each other when installation, otherwise the short circuit may burn the power supply or the main control board.

Quality Assurance:

1. The warranty period of Qilin products is 12 months, starting from the date of delivery.
2. During the warranty period, if there is any fault in hardware such as system motherboard, motor drive, wiring and main display screen, you can send the products back to our company for free maintenance and free labor cost(freight afforded by customer).
3. All lens categories are not covered by warranty, such as collimating lens, focusing lens, reflecting lens, protective lens, seal ring etc.
4. All pistol integral cases, brass nozzles, stainless tubing, wire feed brackets, etc. are not covered by this warranty.
5. If it is necessary to carry out repairs aboard, the travelling expenses shall be paid by the customer.

******All parts of this description, the property right of the book belongs to Shenzhen Qilin Laser Application Technology Co., Ltd., no unit or individual shall reprint, copy or distribute the relevant content of the product description without the permission of Qilin.

If you have any comments or suggestions on the product and instructions during use, please feel free to contact with us !

Company Name: Shenzhen Qilin Laser Application Technology Co., Ltd.

Mob./Wechat: +86-13424151221

Contact: Anita Chou

Thank you for using the products of Qilin !