

Multifunctional portable mug press

User manual

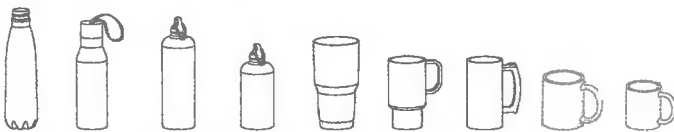
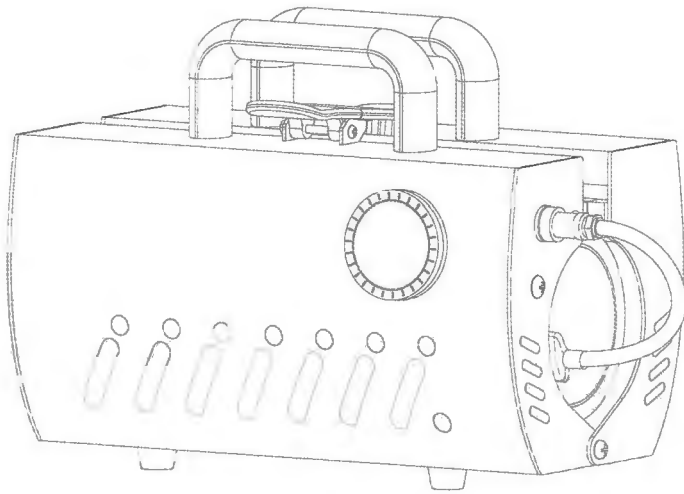

Max. diameter: 85mm Max. length: 260mm

Up to 30OZ aluminum pot cup can be made



Warnings must be followed carefully to avoid body injury.

Introduction

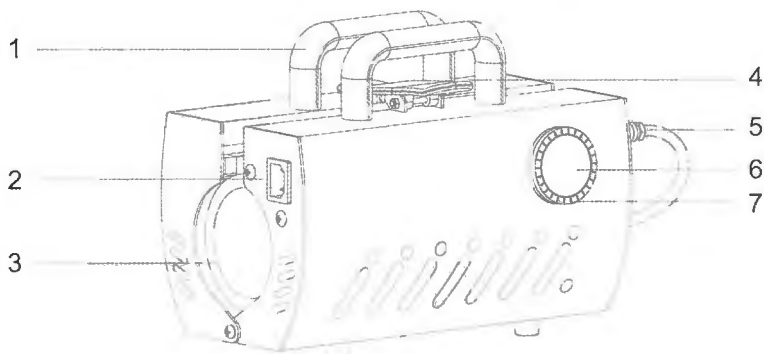

- 1.Handle 2.Power socket 3.Mug heater 4.Clip 5.Aviation connector
6.LED Display 7.Setting knob



Accessories list

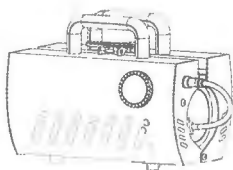

Main machine(with 30oz mug heater)



Power cord



User manual

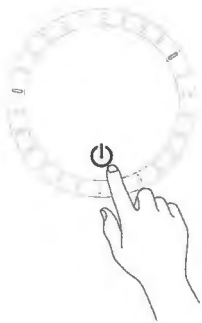

1.Startup

After power on, short press the start button to start the machine.
After startup, the machine will automatically heat up.

2.Shutdown

Press and hold the start button for 3s to shut down.

3.Auto shutdown

The machine will automatically shut down if there is no operation within 60min.

Temperature unit conversion °F ⇌ °C

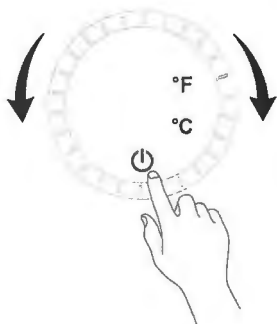

1. In shutdown state
2. Press and hold the start button for 6s.
3. Turn the switch to select the required temperature unit.
4. Short press the start button to start the machine.

Parameter setting



Temperature setting:

1. Turn the display half a turn to the right.
2. Enter the temperature setting mode after a beep sound.
3. Turn the switch to the right again to increase the temperature (+).
4. Turn the switch to the left again to reduce the temperature (-).



Time setting:

1. Turn the display half a turn to the left.
2. Enter the time setting mode after a beep sound.
3. Turn the switch to the right again to increase the time (+).
4. Turn the switch to the left again to reduce the time (-).

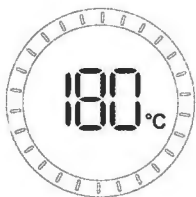

Ready to start

Parameter setting

1. Turn the display for a half turn.
2. Enter the setting mode after a beep sound.
3. Set corresponding parameters according to material type.

185°C 210s

Two 11oz mug presses

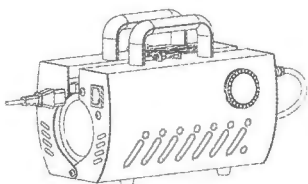

185°C 90s

Aluminum pot cup

Start hot stamping

1. Plug in the power cord and turn on the power
2. Short press the start button to start the machine
3. Set printing temperature and time

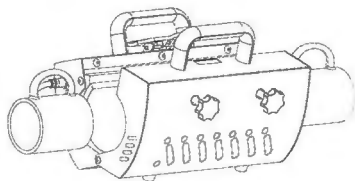

Hot stamping process

1. Make sure that the machine reaches the set temperature before transfer printing.
2. Stick the picture on the mug
3. Open the machine
4. Put the mugs in from the left and right
5. Press down the handle
6. Press the countdown button to start countdown

Tips:

1. Increase the transfer time if the color of the transferred pattern is too light.
2. Reduce the transfer time if the color of the transferred pattern is too dark.

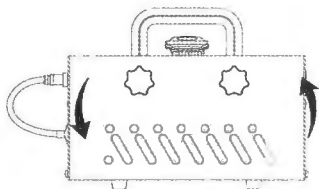

Pressure adjustment

1. The pressure can be adjusted manually for different sizes of mugs
2. Turn the handwheel clockwise to increase the pressure
3. Turn the handwheel counterclockwise to reduce the pressure

Tips:

Please try to keep the pressure balance at both sides.

Electrical Diagram

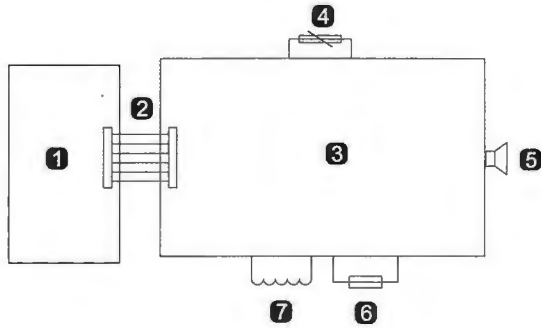

- 1** Main Control Board
- 2** Connect the cable
- 3** Power Strip
- 4** Down temperature sensor
- 5** Buzzer
- 6** Thermal cutoff
- 7** Heating Filament

Main board wiring diagram

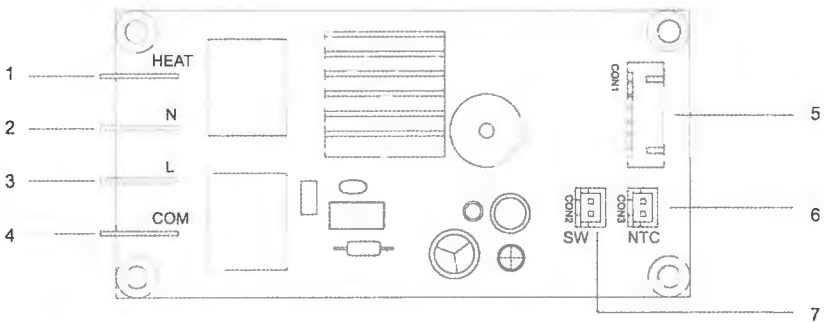

- 1. Output zero line
- 2. Input zero line
- 3. Input live line
- 4. Output live line
- 5. Display
- 6. Temperature probe
- 7. Sensor switch (backup)

Guarantee

The products are strictly based on the Consumer Protection Law of the People's Republic of China and the Product Quality Law of the People's Republic of China. The services are as follows:

Within 12 months this product has the performance failure listed in the Product Performance Failure Table". It is confirmed by manufacturer and can be used for maintenance service free of charge. If out of validity, damage caused by force majeure, or human causes, the machine is not covered by the warranty, repair in charge.

Safety instruction

Before operating this unit, please read these instructions completely and save them. Notice:

1. Keep unplug when moving the machine.
2. Keep unplug when installing accessories.
3. Place on a flat and stable platform and operate under ventilated conditions.
4. Wear special protective equipment when operating the machine

Warning

Improper use may result in electric shock, fire, personal injury and other damage.

1. Do not use this machine in a hazardous location.
2. Do not use when the machine is not working properly.
3. Do not allow children or adults who do not understand this manual to operate this machine.
4. Do not disassemble and repair this machine.
5. Do not use an unsuitable AC outlet.
6. Do not touch the heating plate when the machine heating



Basic Product Parameters

Model: F320	Name: Multifunctional portable mug press
Heating method: Electric heating coil	
Rated voltage/frequency: 120V~60Hz	220-240V~50Hz
Rated power: 620W	
Temperature range: 40°C-210°C(104°F-410°F)	Time range: 1-999s
Press pad size: L 270mm, printing diameter 85mm	
Net weight: 4.8kg Gross weight: 5.3kg	
Outer box size: 360*235*280mm	
Outer box volume: 0.024 cube	

Warranty

Type	Items	Period
Whole machine	Parts of machine (excl. accessories)	1 year
Accessories	Mug heater	No warranty for consumables