

Electric Cap Press

User Manual

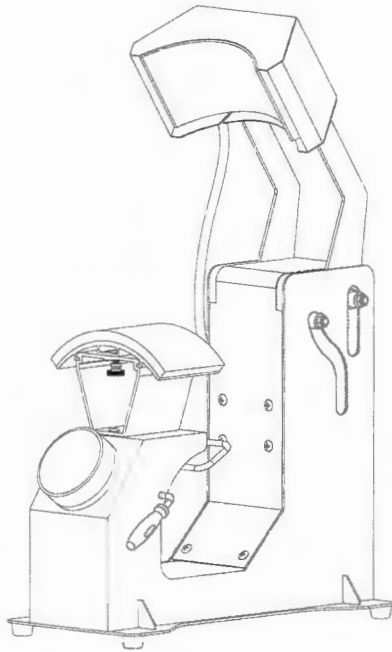

76*140



70*150



98*150

Accessories are optional for different sizes of caps



Warnings must be followed carefully to avoid body injury.

Introduction

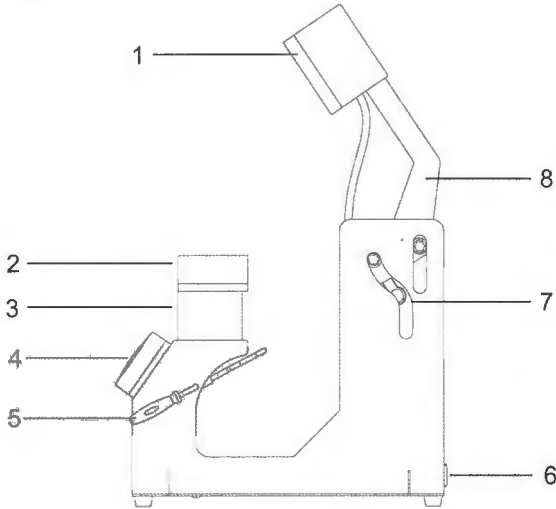

- 1.Heating plate 2.Cap support 3.Cap support seat 4.LED switch
- 5.Cap holder 6.Power socket 7.Guide wheel 8.Bracket

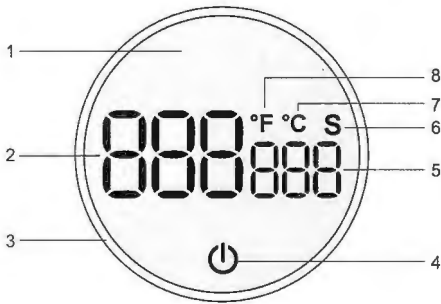

- 1.Translucent cover 2.Temperature display 3.Knob switch 4.Start button
- 5.Time display 6.Time unit 7.Centigrade 8.Fahrenheit

Accessories difference

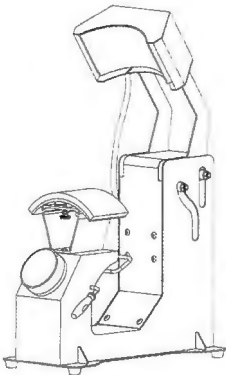

Single

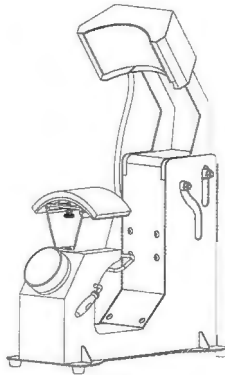

3in1



98*150



70*150

Temperature unit conversion



°F \rightleftharpoons °C

1. In shutdown state.
2. Press and hold the start button for 6s.
3. Turn the switch to select the required temperature unit.
4. Short press the start button to start the machine.

Temperature setting



1. Turn the display half a turn to the right.
2. Enter the temperature setting mode after a beep sound
3. Turn the switch to the right to increase the temperature (+)
4. Turn the switch to the left to reduce the temperature (-)



Time setting

1. Turn the display half a turn to the left
2. Enter the countdown setting mode after a beep sound
3. Turn the switch to the right to increase the time (+)
4. Turn the switch to the left to reduce the time (-)

Getting Started

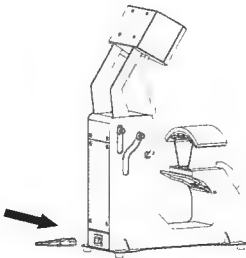

1. Connect the power cord the power cord to the power port on the side of the machine and insert the other end into the AC socket.

2.Startup

After power on, short press the power button to start the machine.

After startup, the machine will automatically heat up.

3.Shutdown

Press and hold the power button for 3s to shut down.

4.Auto shutdown

The machine will automatically shut down if there is no operation within 120min.



Replacement of cap support:

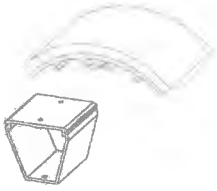

1. Select the cap support to be replaced

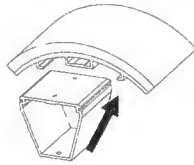

2. Insert into the seat slot

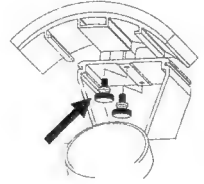

3. Fix with screws



185 °C
25 s

Transfer material: PET film
Turn the switch to the right to set the temperature to 185°C.
Turn the switch to the left to set the time to 25s.



1. Cap to be printed

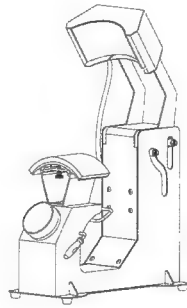

2. Turn on the heating plate to increase the temperature

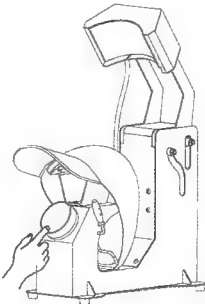

3. The heating plate automatically presses down after pressing the button

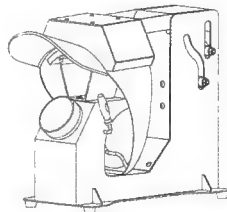

4. The machine automatically opens after countdown

Electrical diagram

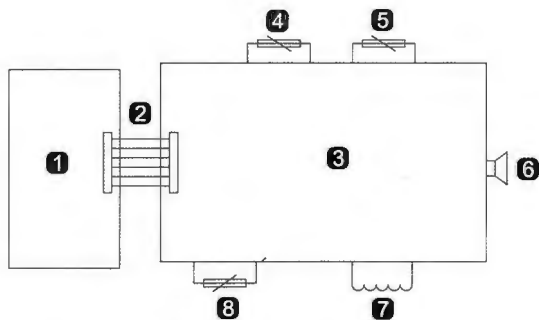

- 1** Main control circuit board **2** Connecting the flat cable **3** Power board **4** NTC temperature sensor
- 5** Magnetic switch **6** Buzzer **7** Heating coil **8** Thermal Fuse

Wiring diagram of circuit board

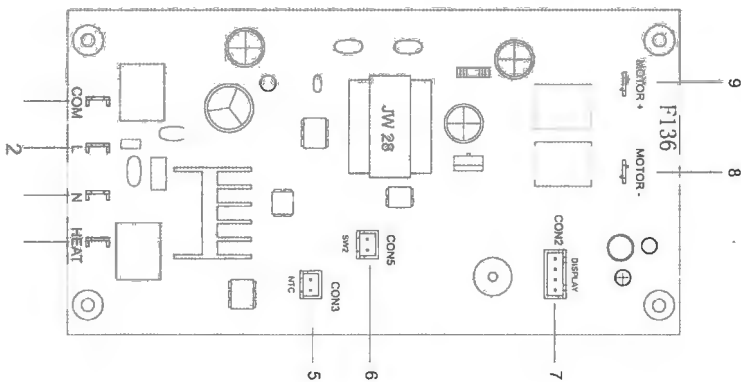

- 1. Output zero line 6. Sensor switch
- 2. Input zero line 7. Display
- 3. Input live line 8. Motor-
- 4. Output live line 9. Motor+
- 5. Temperature probe

Guarantee

The products are strictly based on the Consumer Protection Law of the People's Republic of China and the Product Quality Law of the People's Republic of China. The services are as follows:

Within 12 months this product has the performance failure listed in the Product Performance Failure Table". It is confirmed by manufacturer and can be used for maintenance service free of charge. If out of validity, damage caused by force majeure, or human causes, the machine is not covered by the warranty, repair in charge.

Safety instruction

Before operating this unit, please read these instructions completely and save them.
Notice:

1. Keep unplug when moving the machine.
2. Keep unplug when installing accessories.
3. Place on a flat and stable platform and operate under ventilated conditions.
4. Wear special protective equipment when operating the machine

Warning

Improper use may result in electric shock, fire, personal injury and other damage.

1. Do not use this machine in a hazardous location.
2. Do not use when the machine is not working properly.
3. Do not allow children or adults who do not understand this manual to operate this machine.
4. Do not disassemble and repair this machine.
5. Do not use an unsuitable AC outlet.
6. Do not touch the heating plate when the machine heating



Warning

Basic parameters

Product name: Electric Cap Press
Model: F136
Heating method: Heating coil
Rated voltage/frequency: 120V~60Hz 350W
Rated voltage/frequency: 220-240V~50Hz 310W
Temperature range: 40°C-205°C(104°F-401°F) Time range: 1-999s
Net weight: 7.2kg Gross weight: 8.1kg
Outer box size: 420*200*395mm
Outer box volume: 0.033 cube

Warranty

Type	Items	Period
Whole machine	Parts of machine (excl. accessories)	1 year
Accessories		No warranty for consumables