

Celtic Knot – Introduction

The EnRoute Step-by-Step series of tutorials was created as a way of demonstrating many of the key concepts in EnRoute. Each of the tutorials provides instructions for creating a design and a finished piece using a primary EnRoute concept. Our goal is to provide examples that are relatively easy to follow and accomplish, and that demonstrate an interesting element of EnRoute.

In this short tutorial we will create artwork for a Celtic Knot that is then be used in four tutorials that each demonstrates a design and toolpath method. The design is simple but once you understand the methods you will be able to apply them to your designs.

The inspiration for a design can come from almost anywhere. This was found in one of the Dover Clip Art books. The EnRoute drawing tools were used to create the vector artwork that serves as the starting point for our other designs.



This is the original bitmap.

The following steps can be followed to create EnRoute artwork:

1. Define the Plate – Enter these parameters and click OK.

Width 5.00

Height 5.00

Thickness .75

Surface at the top of Plate.

The plate is used primarily as a reference for the design.

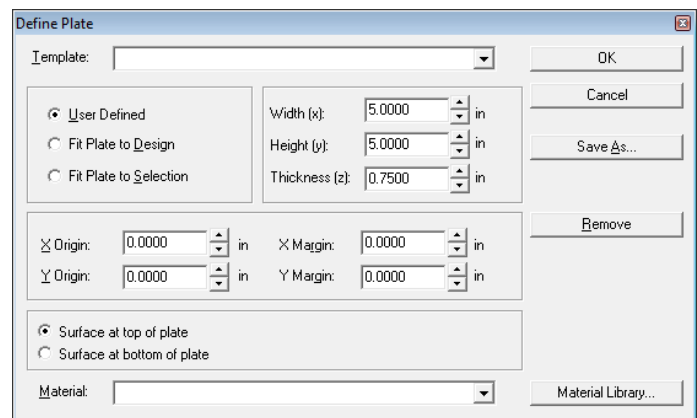

EnRoute Step-by-Step Series

- Use the Circle tool to create the first circle of the design.

Click on the Draw Circle Icon. 
 This will open the Circle Dialog.

Select the Circle by center and radius tool. 
 Enter the radius of the circle. In this example we use a radius of 2.30". EnRoute shows a preview of the circle in pink.

Move the cursor to the center of the plate and left click to place the circle.
 You can also enter the placement parameters of the circle and then click Apply to place the circle.

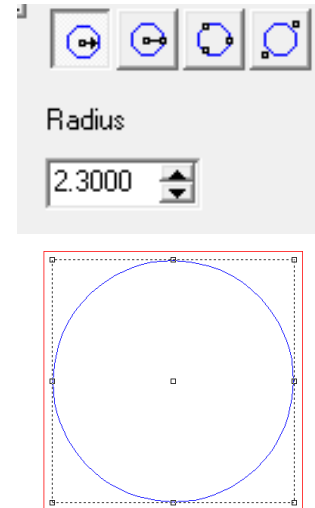

- Click on the Offset tool to create an inline for the circle.  This will open the Offset Dialog.

Enter parameters:
 Number =1
 Amount = .25
 Inline
 Rounded

As you enter these parameters, EnRoute shows a preview in green.

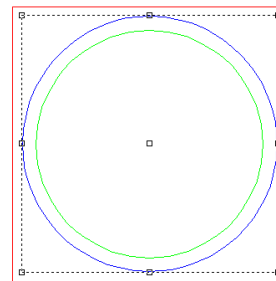
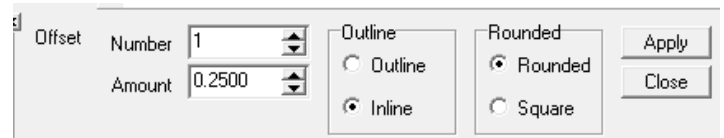

Click **Apply** to place the circle.

- Group the two circles together by selecting both of the circles and click on the Group Icon. 

This will allow you to treat this as one object.

- Using the object that you have just created, we will build the design. If you notice, the Celtic Knot is made up of several circles that intersect each other. The guidelines help to position the additional objects.

To place the guidelines, we first select the circle. The selection box shows you the center point of the circle. Place the guideline by left-clicking on the ruler and then dragging the guideline out into the design. Align each guideline with the center point of the selection box of the circle.

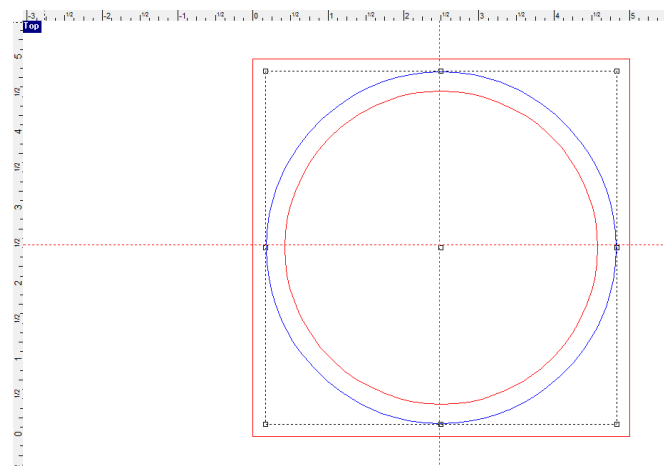

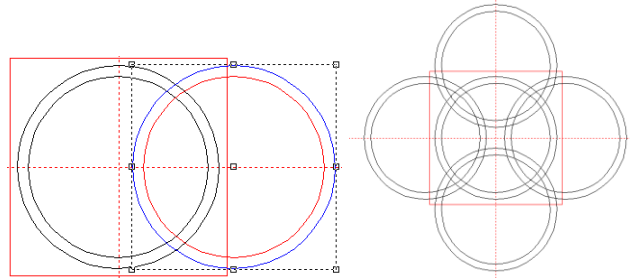

EnRoute Step-by-Step Series

6. Select the circle object and hold down the Shift and Ctrl keys and drag the copy of the circle to one side of the original. Repeat this step so that you drag a copy of the circle to each direction so that you end up with 5 circles.

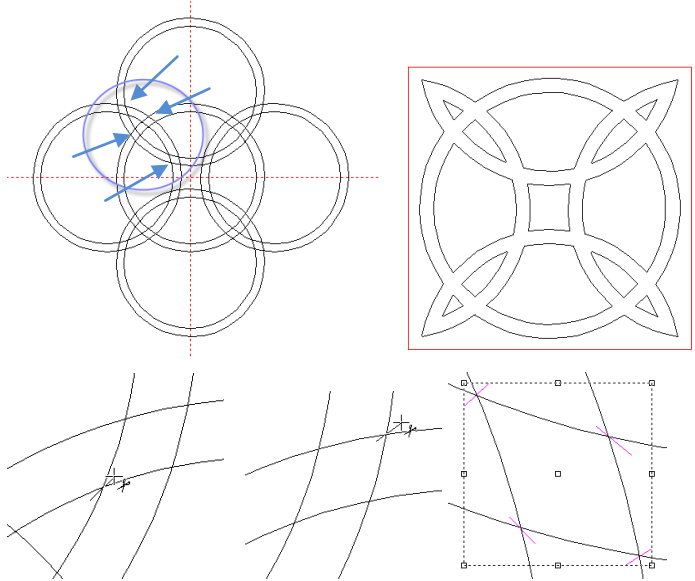

7. Next use the Cut By Line tool  to cut the contours at the points where the design will be reconnected to form the new contour of the finished design.
The arrows are pointing to the areas that will be cut and joined. The second image shows the results that we are looking for.
The bottom images show that the cut by line tool was used to cut the contours at the points of the design where they intersect.



Click and hold the Weld tool  to open the flyout menu and then click on the Cut by Line icon. 

Move the cursor to the point that you wish to start the tool. Left click and drag the cursor to the end point and left click again. This will cut the contours at the point that the line has intersected the contours.

8. Delete the contours that you don't need from the outside of the design.

Notice that in this image the contours from the first 3 circles have already been deleted.

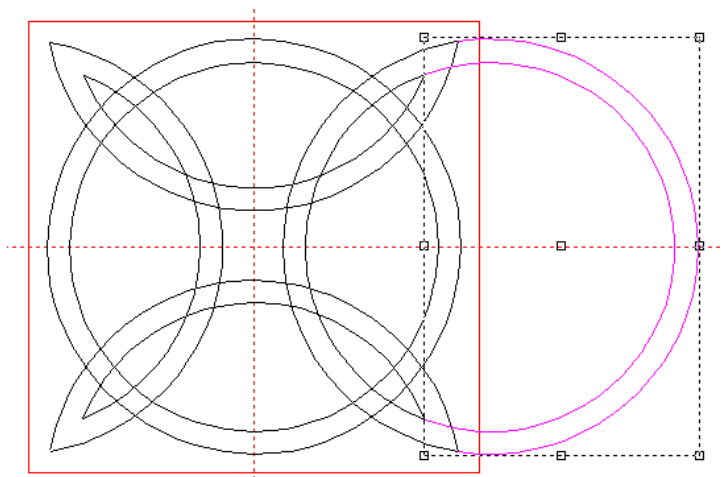

EnRoute Step-by-Step Series

9. At this point we will now join the contours together at the points that the cut by line tool was used. Click on the Join Contours Icon.  Move the cursor to the end of the contour. When you get the cursor close, the open contour will be highlighted in green. Left click to select the first contour. Move the cursor to the end of the second open contour that you wish to connect to. It will highlight in green. Left click again to join the two contours. Remember: Open contours when selected will displayed in pink, closed contours show in blue.
10. These contours are used in creating the toolpaths for the inlay design and the 2D fill design.

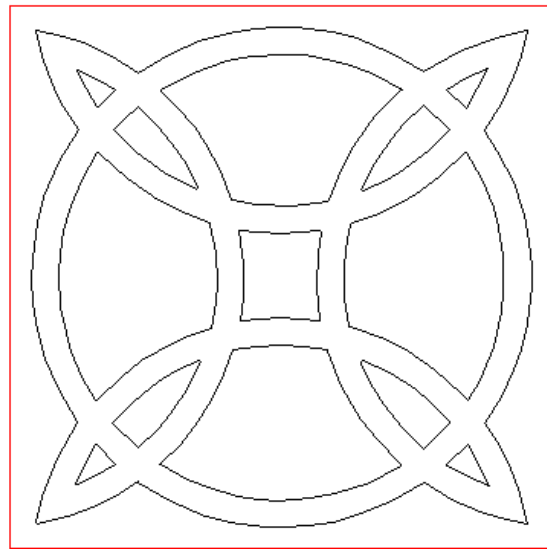
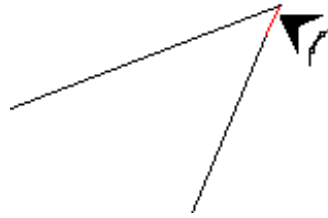

11. The contours for the 2.5D fill are a bit different from the 2D contours. There is a break in the contours at the point where the knot design would cross over or under. Creating the objects of the design in this manner will help to give the illusion that they are passing over and under each other.

This is the design that we demonstrate in the next few steps.

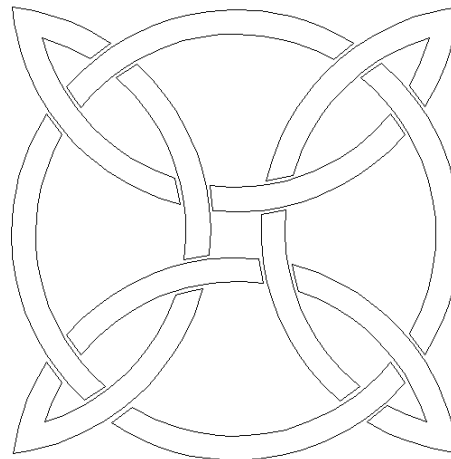

EnRoute Step-by-Step Series

12. Starting with the 2D design that we created in the first portion of these instructions.

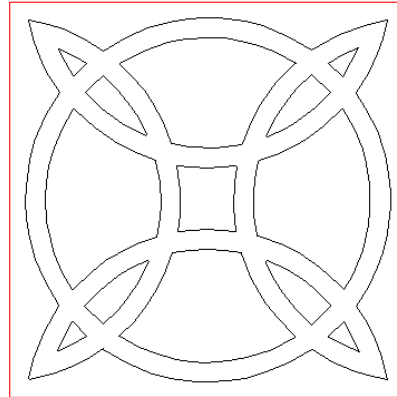

13. The design must be modified in order to create the effect of the weaving of the knot. Lines are drawn across the design to create the division of the contours at the places where the rope traveled over and under in the design. It was helpful to have the original image displayed while doing this task.

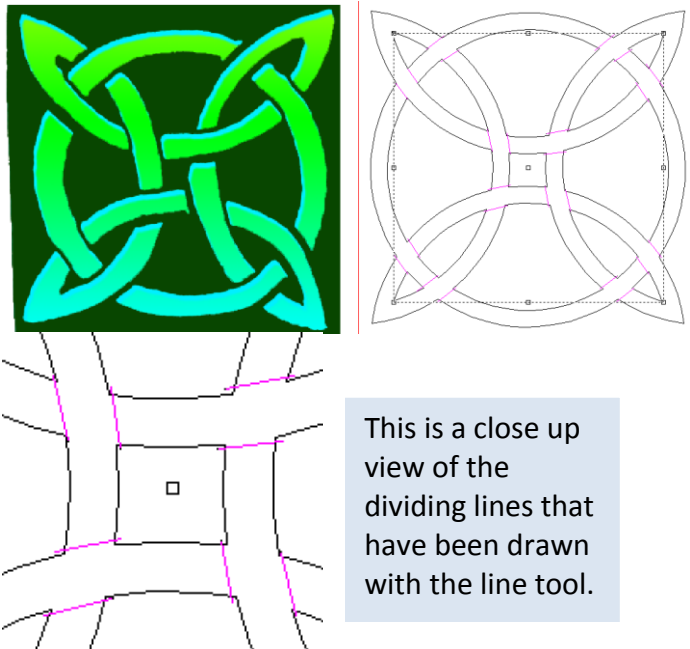

This is a close up view of the dividing lines that have been drawn with the line tool.

14. In this design, it is very helpful to create different layers for each of the “rings” of the design. This will make the design much easier to work with.

To create a new layer, click on the Layers Icon.



This will open the Layers Dialog.

Click on the New button. Notice that a new layer is created and named Layer 2.

Highlight the name.

Type in the new name for this layer.

Click Ok to accept the changes.

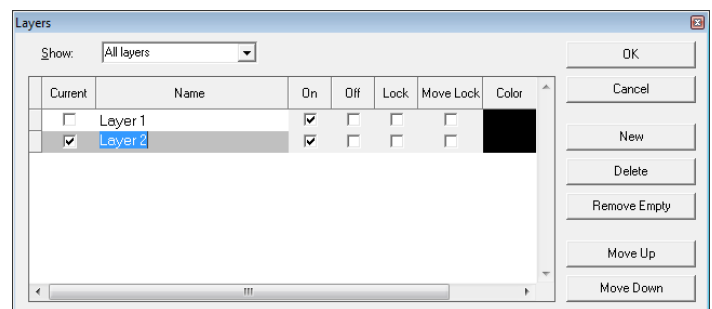

EnRoute Step-by-Step Series

15. Create 3 new layers. In this example, we have named them How to 1, 2, etc. The first layer is the original layer that we were working with. It contains the design and the division lines. We will now work with the new layers to create each part of the design.

16. Turn on only the Layer with your original design and one other new layer. Notice that the layer that you will be working in is the current layer. Click Ok.

17. This is a close up view of the division lines. The Jigsaw Weld tool  can be used to create the contours that we will need to design the 3D relief.

18. Click and hold the Weld Joined Icon. This will open the flyout menu to allow access to the Jigsaw Weld Tool.



19. Click on the Jigsaw Weld tool  and then pass the cursor over the area that you wish to capture. Once this area turns pink, left click to create the new contour.

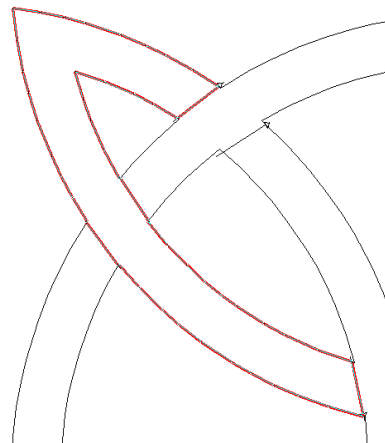
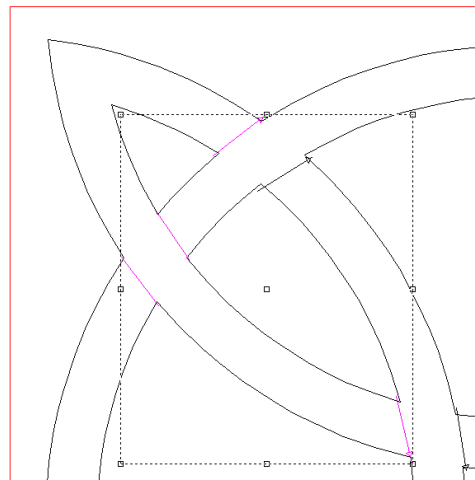
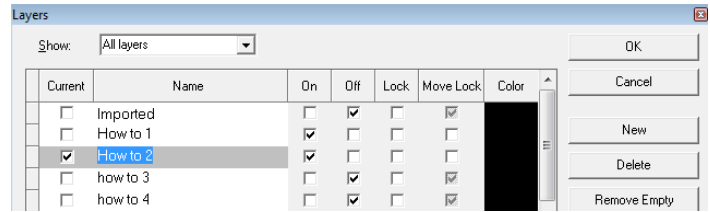
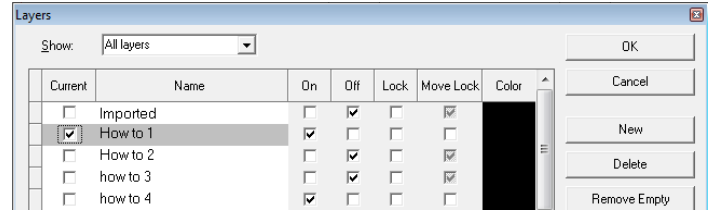

EnRoute Step-by-Step Series

20. Continue to create the contours for this layer named “How to 2” by passing the cursor over the area until it is highlighted, and then left click to place the contour.

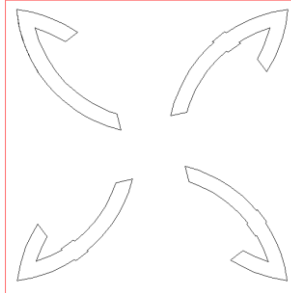

21. Repeat steps 6-9 for the next two layers.

This layer was named “How to 3”.

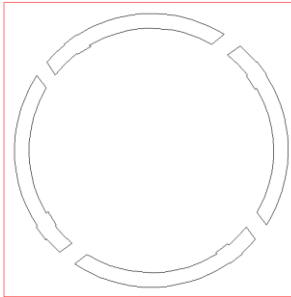

22. This layer was named “How to 4”

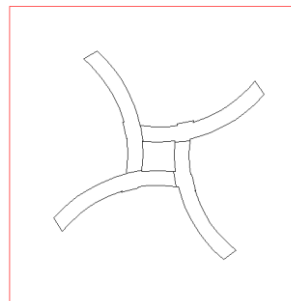

23. In this example, we changed the color of the layers. The contours on each of the layers will show with the color that has been assigned to that layer. This is another tool that EnRoute has to help you to organize your designs.

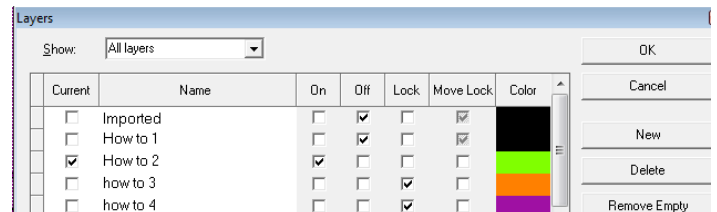

To do this, open the Layers Dialog.

Double click in the color box for the layer that you wish to change.

Select the color for that layer.

Click OK. The contours will now be displayed in that selected color.

EnRoute Step-by-Step Series

24. The first image shows all 3 layers displayed together. Notice that the contours are displayed in the colors that you set up in the layers dialog. Make sure that the contour you wish to edit is on the current layer. The second image shown here is a close up view which shows the point editing that needs to be done.

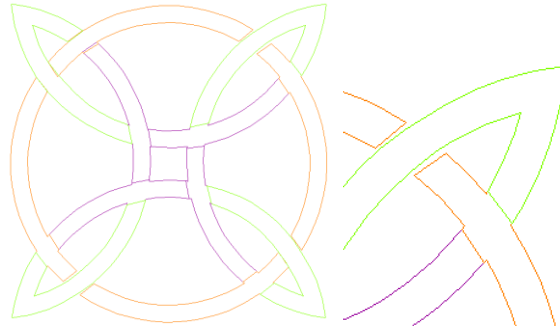

25. Use the Edit Points tool  to clean up the contours. The goal is to edit the contours so that they are offset just a little from the other contours.



26. This is an image of the finished work. This will be used with the 2.5D instructions.

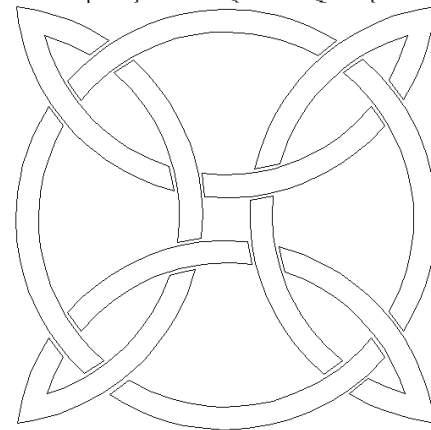

27. This same process is used for the 3D image except that you want to edit the contours so that they are lined up with the contours that they meet with.

Go to the layer that you wish to work on.

Click on the contour.

Click on the Edit Points icon.  Click on the points that you want to edit.

Continue to clean up all of the contours.

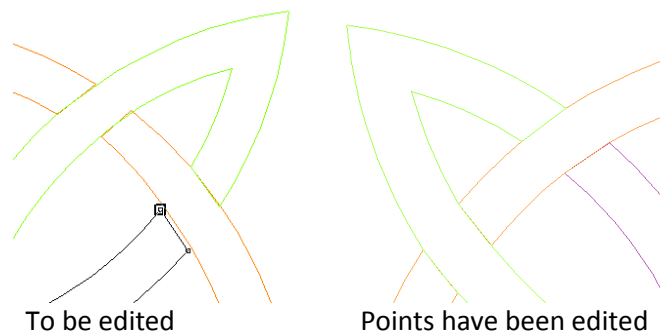

EnRoute Step-by-Step Series

28. This is an image of the design that will be used to create the 3D Relief.

