

DATI MOTORE E CURVE CARATTERISTICHE / PERFORMANCES AND MOTOR RATINGS

Tensione / Voltage	V ±10%	380	380	380
Potenza resa / Output Power	kW	1 (1,3)	1 (1,3)	1 (1,3)
Corrente nom. / Current	A	3,2 (4,2)	3,2 (4,2)	2 (2,4)
Frequenza / Frequency	Hz	300	400	500
rpm	rpm	18000	24000	30000
Coppia nom. / Torque	Nm	0,53 (0,69)	0,4 (0,52)	0,32 (0,38)
Cuscinetto Ant. / Front Bearing		tandem		
Cuscinetto Post. / Post. Bearing		tandem		
Rendimento / Efficiency	η	0,65		
Fattore di potenza / Power factor	cos φ	0,75		
Numero di poli / Poles		2		
Tipo di servizio / Service type		S1 (S6 40%)		
Classe di isolam. / Insulation class		F		
Raffreddamento / Cooling		Liquido		
Peso / Weight	Kg	3,5		
Grado IP / Type of Protection	IP	54		

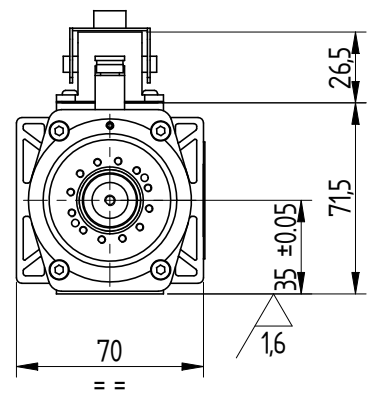
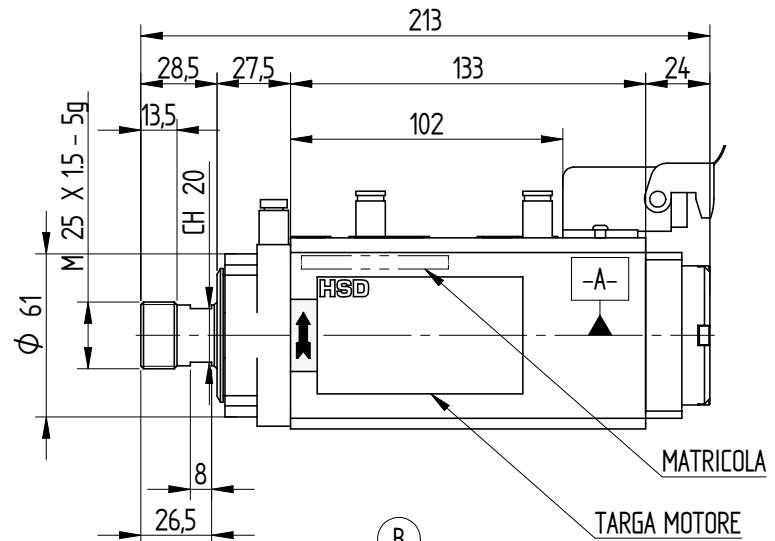
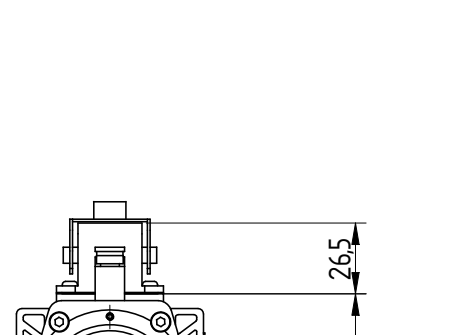

CONNESSIONI ELETTRICHE / ELECTRIC CONNECTIONS

Nr. Pin	Descrizione / Description
1	U Fase / Motor phase
2	V Fase / Motor phase
3	W Fase / Motor phase
4	** Bimetallo / Bi-metallic
5	** Bimetallo / Bi-metallic
⊕	Terra elettromandrino / Earth connection

** Vedi "Manuale istruzioni ed avvertenze per l'uso" per le caratteristiche tecniche
 ** See "User's guide" for technical informations

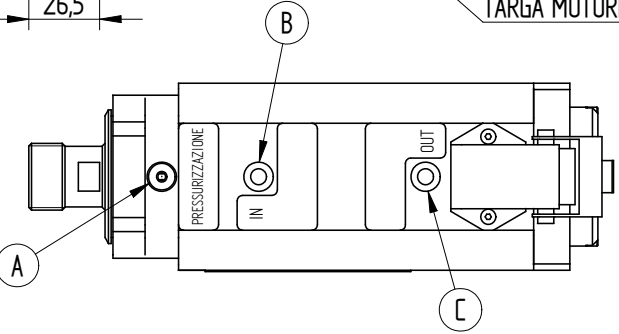

UTENZE		
A	PRESSURIZZAZIONE	TUBO φ4 - 2bar
B	INGRESSO REFRIGERANTE	TUBO φ6
C	USCITA REFRIGERANTE	TUBO φ6

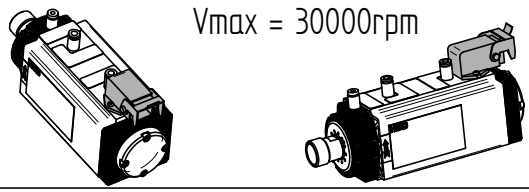

REVISIONI / REVISIONS				DESCRIZIONE REVISIONE / REVISION DESCRIPTION		DATA / DATE	FIRMA SIGN
REV.	DISEGNATO / DRAW BY	CONTROLLATO / CHECKED BY	APPROVATO / APPROVED	SCALA / SCALE:	12		
	DATA DATE	11/07/2011	14/07/2011	PESO / WEIGHT:			
	FIRMA SIGN	L.Loffredo	A.Pietropaolo	GREZZO DI: RAW:			
MATERIALE: MATERIAL:				SOSTITUISCE: REPLACE:		CICLO DI VERNICIATURA: PAINTING CYCLE:	
TRATTAMENTO TERMICO: HEAT TREATMENT:				RIVESTIMENTO SUPERFICIALE: SURFACE TREATMENT:		DENOMINAZIONE: DESCRIPTION:	
RIPRODUZIONE E/O DIFFUSIONE VIETATA / REPRODUCTION AND/OR DISCLOSURE OF THE DRAWING IS FORBIDDEN				AT1055-070-LIQ-ER20-380V-DX-18/3000-1kW S1			

HSD DIVISION

A3

UNI EN 20782-18-FH

6162H0086