

DATI MOTORE E CURVE CARATTERISTICHE / PERFORMANCES AND MOTOR RATINGS

Tensione / Voltage	V ±10%	220	
Potenza resa / Output Power	kW	6 (7,2)	
Corrente nom. / Current	A	20,8 (25)	
Frequenza / Frequency	Hz	300	
rpm	rpm	18000	
Coppia nom. / Torque	Nm	3,18 (3,82)	
Cuscinetto Ant. / Front Bearing		cont.obliquo	
Cuscinetto Post. / Post. Bearing		radiale	
Rendimento / Efficiency	η	0,86	
Fattore di potenza / Power factor	cos φ	0,88	
Numero di poli / Poles		2	
Tipo di servizio / Service type		S1 (S6 40%)	
Classe di isolam. / Insulation class		F	
Raffreddamento / Cooling		Aria forzata	
Peso / Weight	Kg	10	
Grado IP / Type of Protection	IP	50	

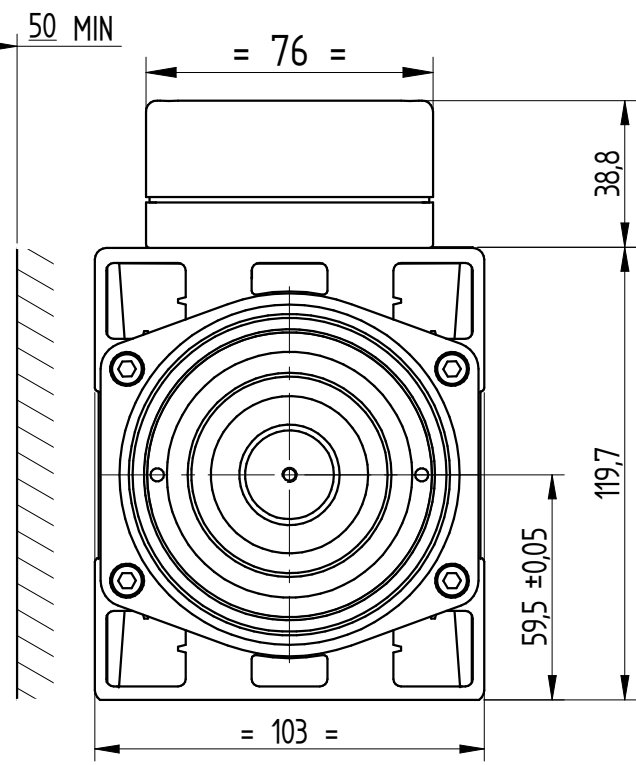
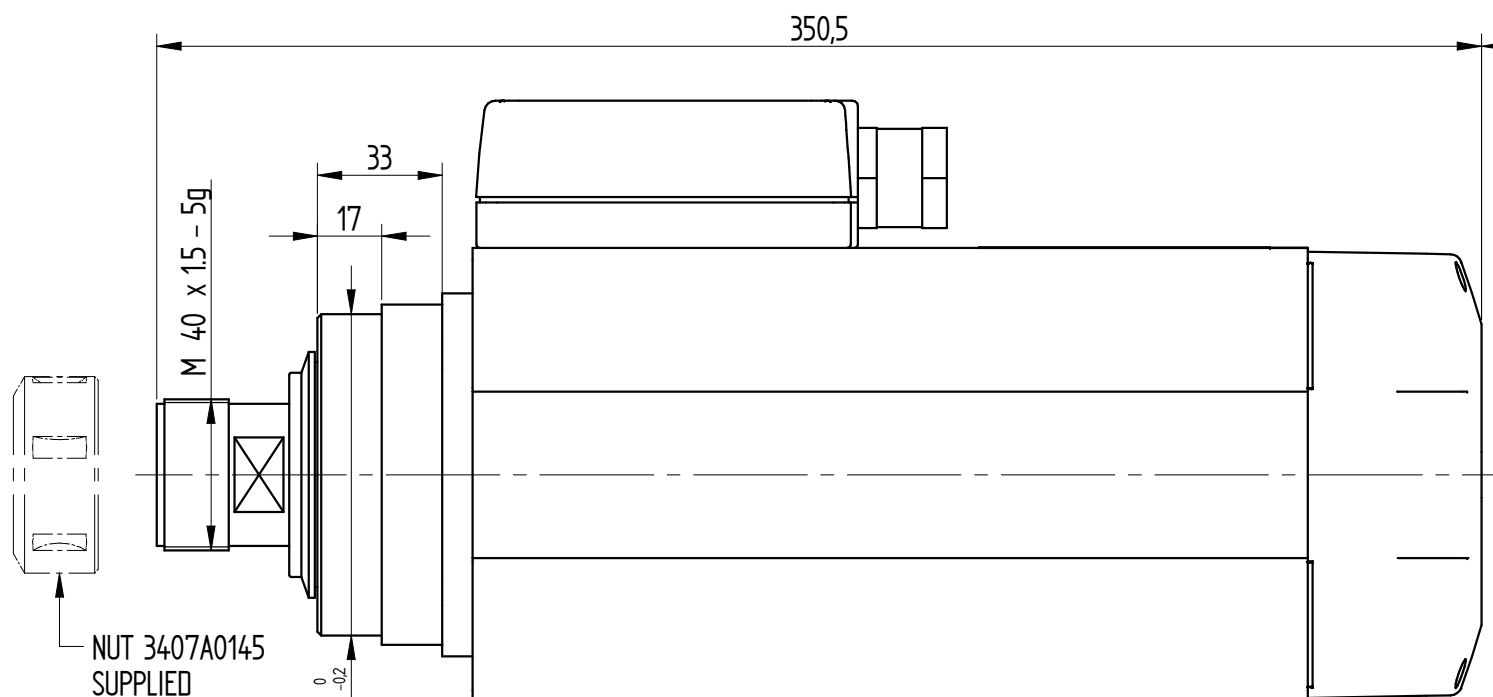
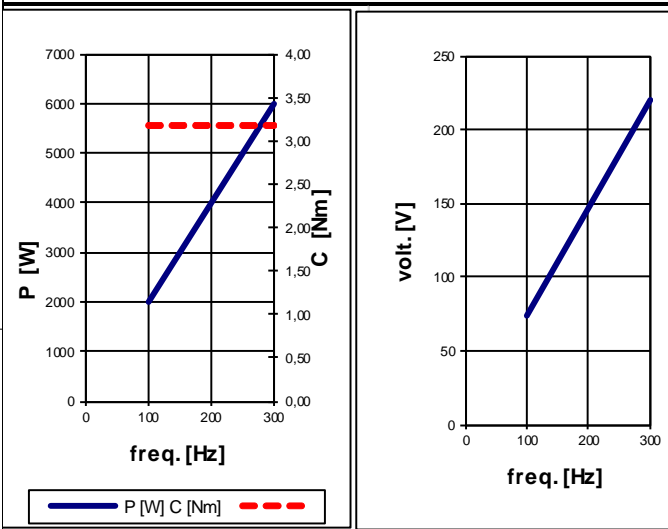

CONNESSIONI ELETTRICHE / ELECTRIC CONNECTIONS

Nr. Pin	Descrizione / Description
1	U Fase / Motor phase
2	V Fase / Motor phase
3	W Fase / Motor phase
4	** Bimetallo / Bi-metallic
5	** Bimetallo / Bi-metallic
⊕	Terra elettromandrino / Earth connection

** Vedi "M annuale istruzioni ed avvertenze per l'uso" per le caratteristiche tecniche
** See "User's guide" for technical informations

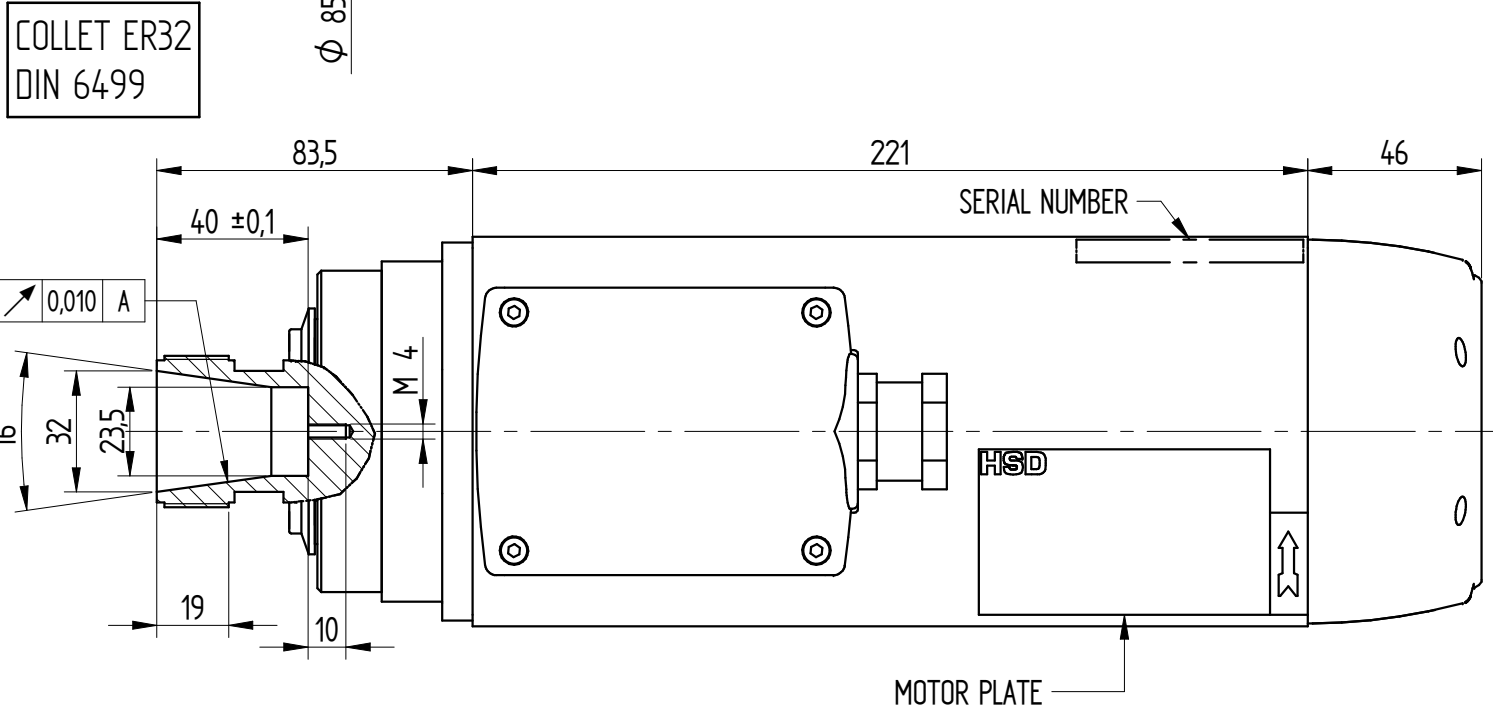

P0	Prima emissione prototipale / First prototype emission			17/10/2018	HSD
0	First Production submission			03/12/2018	
REV.	DESCRIZIONE REVISIONE / REVISION DESCRIPTION	N°	N° CR	DATA / DATE	FIRMA / SIGN: M. Bugari
					STATO / STATUS: Production
					A3
					SCALA / SCALE: 1:2
					FOLGIO / SHEET: 1 / 1
					PESO / WEIGHT: 11,618 kg
					GREZZO DA / RAW BY:
					COD. GREZZO / RAW CODE:
					QUOTE SENZA INDICAZIONE DI TOLLERANZA DIMENSIONI WITHOUT TOLERANCE INDICATIONS
					- LAVORAZIONI MECCANICHE / MACHININGS:
					- SALDOCARPENTERIE / WELDED STRUCTURES:
					- GETTI - ESTRUSI - STAMPATI / CASTINGS - EXTRUDED - MOULDED:
					CICLO DI VERNICIATURA / PAINTING CYCLE:
					DENOMINAZIONE / DESCRIPTION: ELETTRIMANDRINO MT1090-140-ER32-220V-DX-18/18000-6KW S1-AL
					CODICE CODE: H6162H0171
					REVISIONE REVISION: 0

0,010 A

16°

MOTOR PLATE

SERIAL NUMBER

HSD

RIPRODUZIONE E/O DIFFUSIONE VIETATA
 REPRODUCTION AND/OR DISCLOSURE OF THE
 DRAWING IS FORBIDDEN