

DATI MOTORE E CURVE CARATTERISTICHE / PERFORMANCES AND MOTOR RATINGS

Tensione / Voltage	V ±10%	380	380
Potenza resa / Output Power	kW	6 (7,2)	6 (7,2)
Corrente nom. / Current	A	12 (14,4)	12 (14,4)
Frequenza / Frequency	Hz	300	400
rpm	rpm	18000	24000
Coppia nom. / Torque	Nm	3,18 (3,82)	2,39 (2,87)
Cuscinetto Ant. / Front Bearing		cont.obliquo	
Cuscinetto Post. / Post. Bearing		radiale	
Rendimento / Efficiency	η	0,86	
Fattore di potenza / Power factor	cos φ	0,88	
Numero di poli / Poles		2	
Tipo di servizio / Service type		S1 (S6 40%)	
Classe di isolam. / Insulation class		F	
Raffreddamento / Cooling		Aria forzata	
Peso / Weight	Kg	10	
Grado IP / Type of Protection	IP	50	

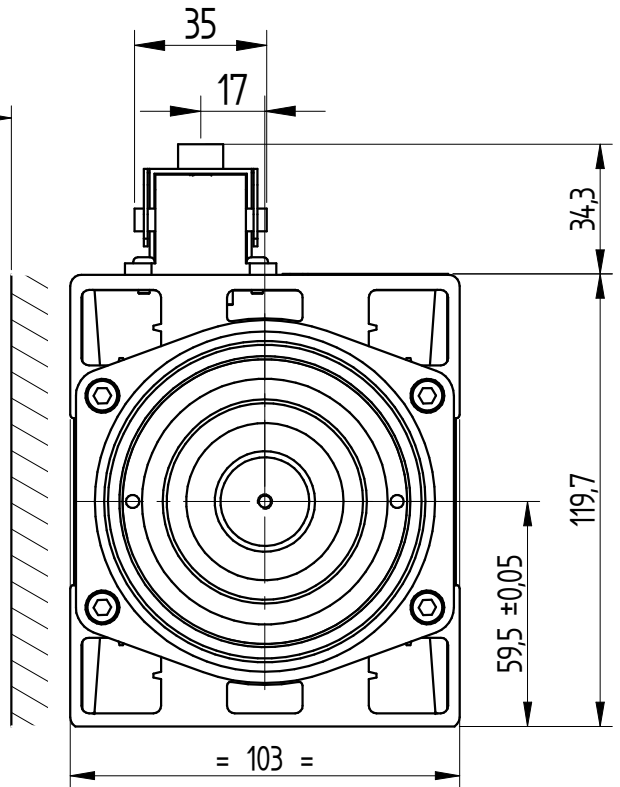
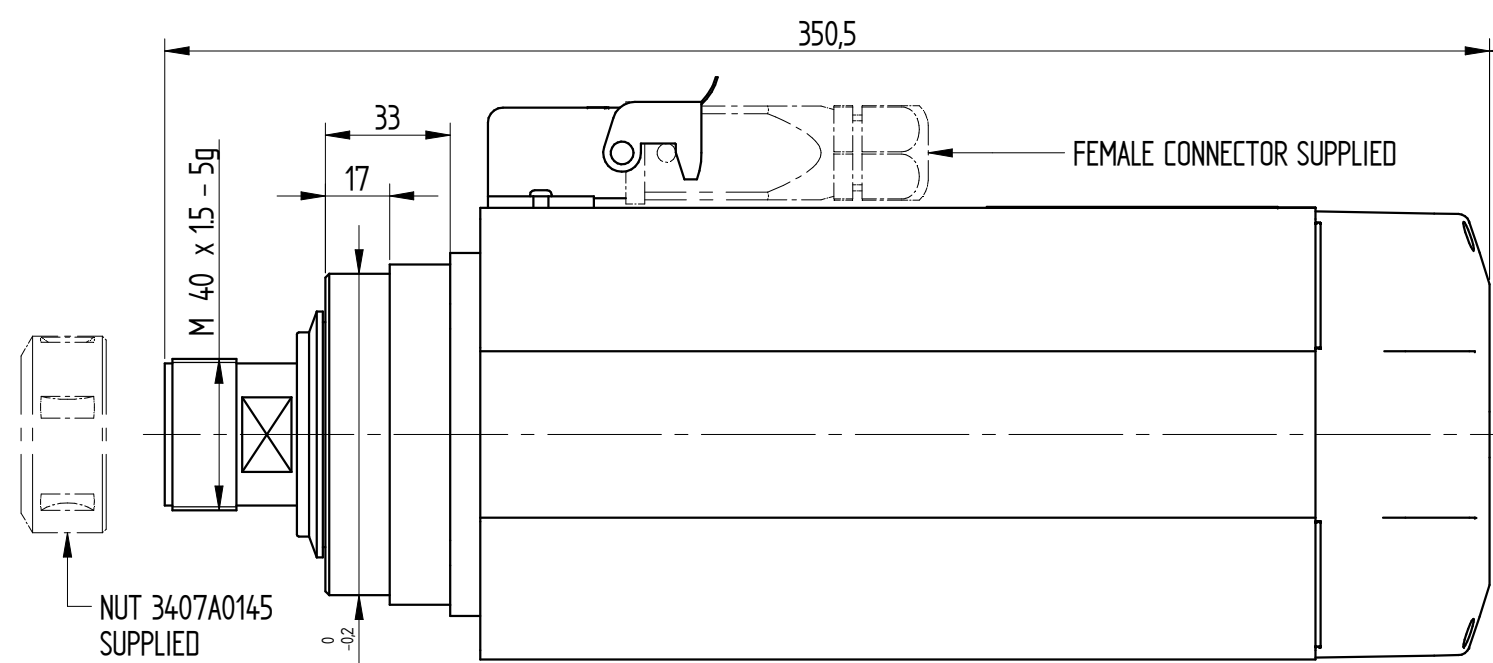
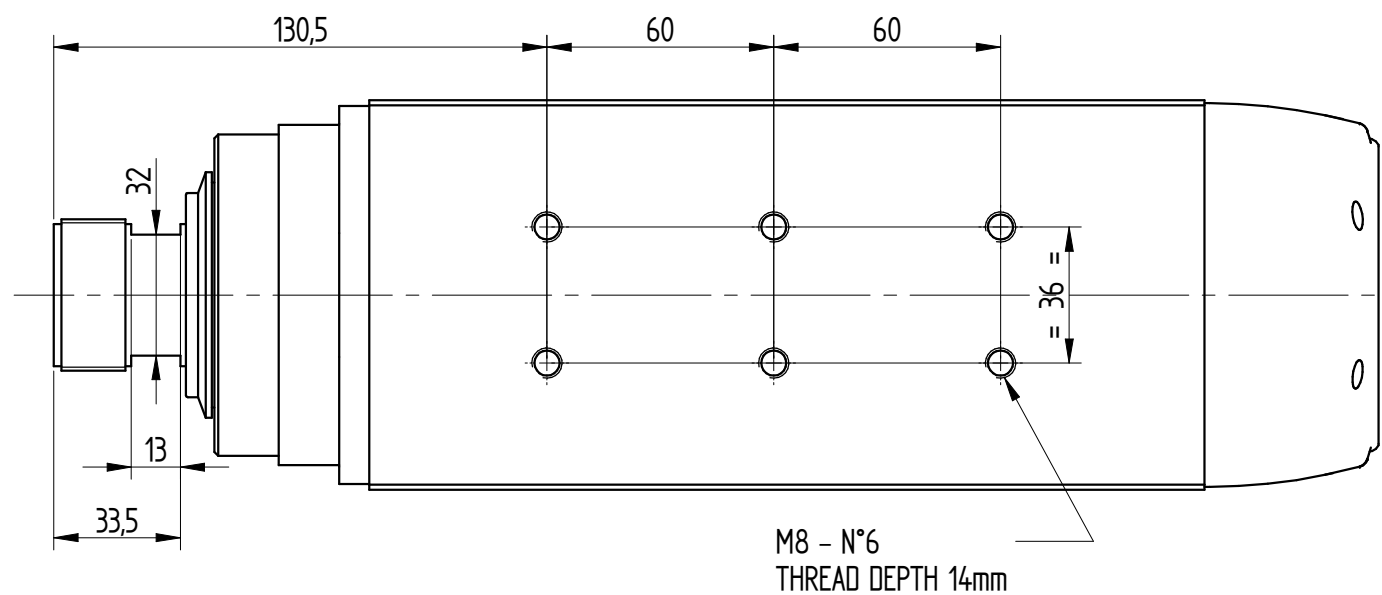
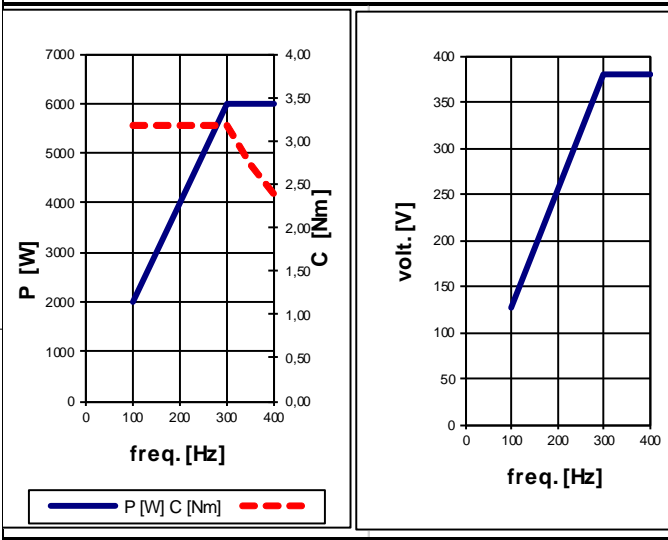

CONNESSIONI ELETTRICHE / ELECTRIC CONNECTIONS

Nr. Pin	Descrizione / Description
1	U Fase / Motor phase
2	V Fase / Motor phase
3	W Fase / Motor phase
4	** Bimetallo / Bi-metallic
5	** Bimetallo / Bi-metallic
⊕	Terra elettromandrino / Earth connection

** Vedi "Manuale istruzioni ed avvertenze per l'uso" per le caratteristiche tecniche
 ** See "User's guide" for technical informations

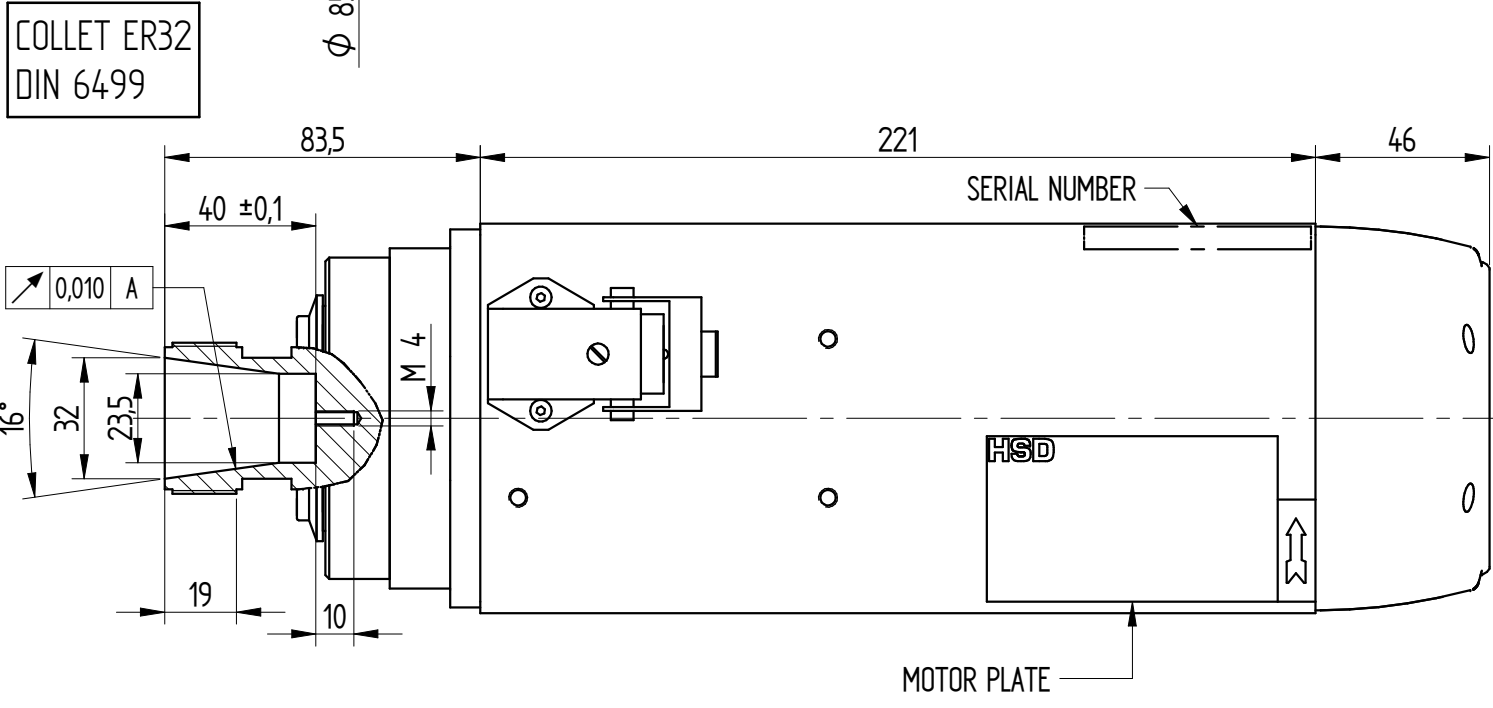

P0	Prima emissione prototipale / First prototype emission			17/10/2018	HSD		
0	First Production submission			03/12/2018	FIRMA / SIGN: M. Bugari	⊕	
REV.	DESCRIZIONE REVISIONE / REVISION DESCRIPTION	N°	N° CR	DATA / DATE	STATO / STATUS: Production	A3	
	DISEGNATO / DRAWN BY	CONTROLLATO / CHECKED BY	APPROVATO / APPROVED BY	PESO / WEIGHT: 11,436 kg	SCALA / SCALE: 1:2	FOGLIO / SHEET: 1 / 1	
	DATA DATE	12/10/2018	17/10/2018	03/12/2018	QUOTE SENZA INDICAZIONE DI TOLLERANZA DIMENSIONS WITHOUT TOLERANCE INDICATIONS		
	FIRMA SIGN	M. Bugari	M. Bugari	G. Grosso	- LAVORAZIONI MECCANICHE / MACHININGS:		
	MATERIALE / MATERIAL:					- SALDOCARPENTERIE / WELDED STRUCTURES:	
	TRATTAMENTO TERMICO / HEAT TREATMENT:					- GETTI - ESTRUSI - STAMPATI / CASTINGS - EXTRUDED - MOULDED:	
	RIVESTIMENTO SUPERFICIALE / SURFACE TREATMENT:					CICLO DI VERNICIATURA / PAINTING CYCLE:	
	DENOMINAZIONE / DESCRIPTION:	ELETTROMANDRINO MT1090-140-ER32-380V-DX-18/24000-6KW S1-AL				CODICE CODE: H6162H0170	REVISIONE REVISION: 0