

ATTACCO PINZA ER25
DIN 6499

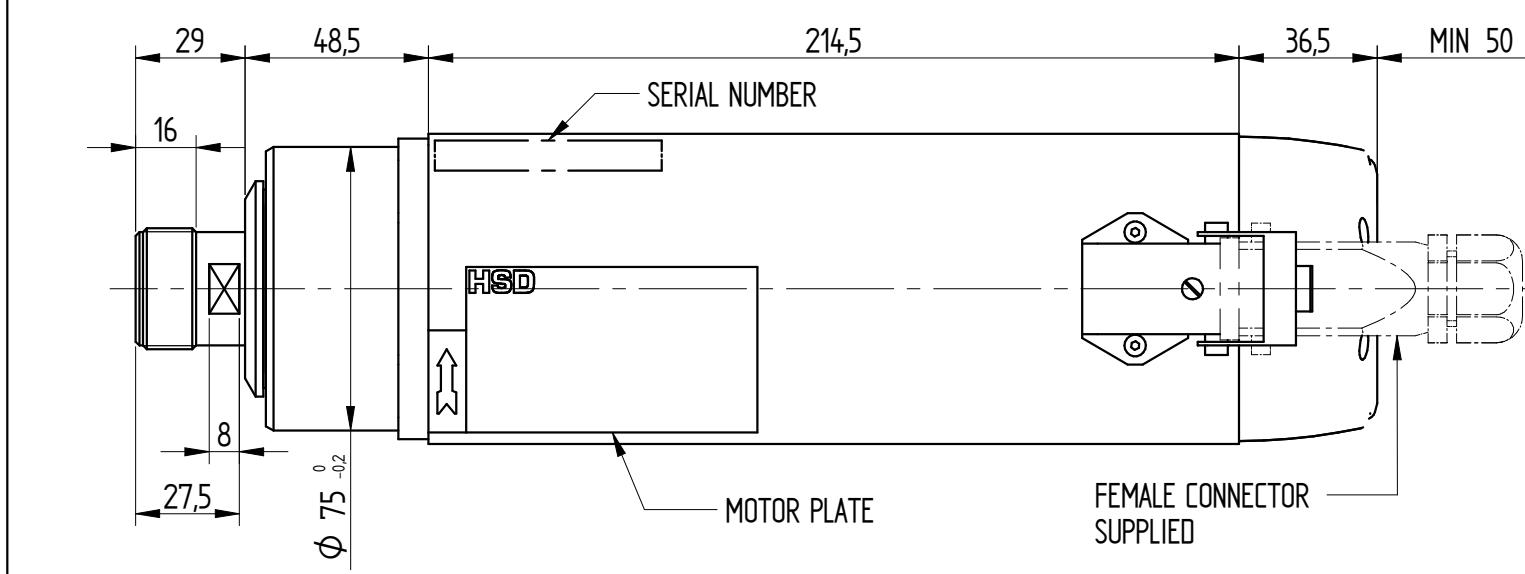

DATI MOTORE E CURVE CARATTERISTICHE / PERFORMANCES AND MOTOR RATINGS

Tensione / Voltage	V ±10%	380	
Potenza resa / Output Power	kW	3 (3,6)	
Corrente nom. / Current	A	7,2 (8,3)	
Frequenza / Frequency	Hz	300	
rpm	rpm	18000	
Coppia nom. / Torque	Nm	1,6 (1,9)	
Cuscinetto Ant. / Front Bearing		ceramici	
Cuscinetto Post. / Post. Bearing		radiale	
Rendimento / Efficiency	η	0,75	
Fattore di potenza / Power factor	cos φ	0,77	
Numero di poli / Poles		2	
Tipo di servizio / Service type		S1 (S6 40%)	
Classe di isolam. / Insulation class		F	
Raffreddamento / Cooling		Aria forzata	
Peso / Weight	Kg	8	
Grado IP / Type of Protection	IP	50	

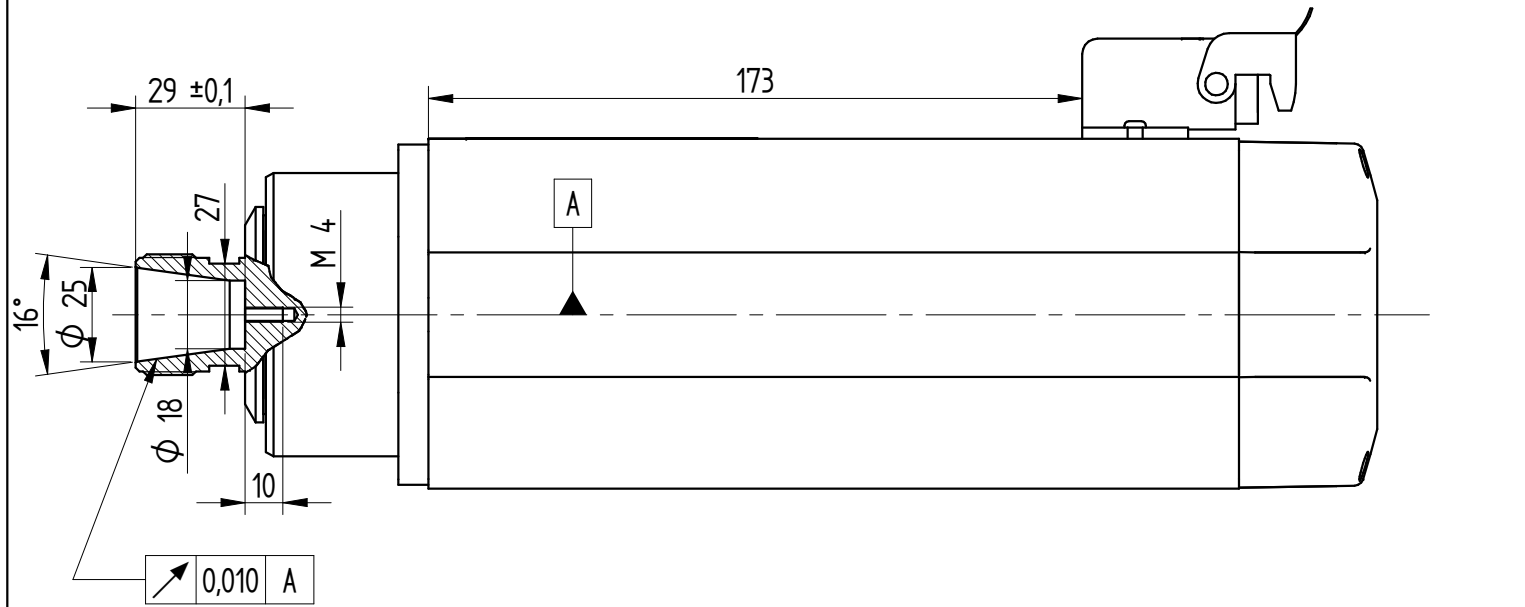
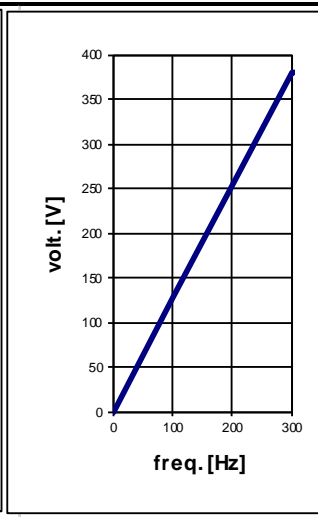
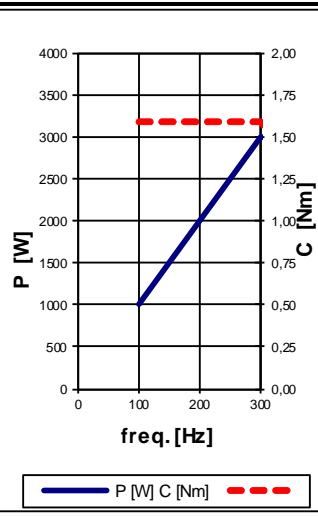

CONNESSIONI ELETTRICHE / ELECTRIC CONNECTIONS

N° Pin	Descrizione / Description
1	U Fase / Motor phase
2	V Fase / Motor phase
3	W Fase / Motor phase
4	** Bimetallo / Bi-metallic
5	** Bimetallo / Bi-metallic
⊕	Terra elettromandrino / Earth connection

** Vedi "Manuale istruzioni ed avvertenze per l'uso" per le caratteristiche tecniche
** See "User's guide" for technical informations

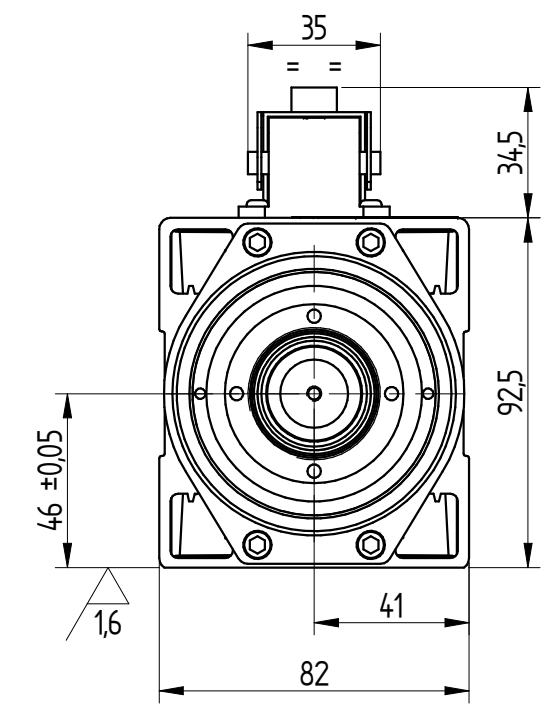

				HSD	
P0	Prima emissione prototipale / First prototype emission			17/10/2018	
0	First Production submission			03/12/2018	FIRMA / SIGN: M. Bugari
REV.	DESCRIZIONE REVISIONE / REVISION DESCRIPTION	N°	N° CR	DATA / DATE	STATO / STATUS: Production
	DISEGNATO / DRAWN BY	CONTROLLATO / CHECKED BY	APPROVATO / APPROVED BY	PESO / WEIGHT: 8,583 kg	SCALA / SCALE: 1:2
	DATA DATE	03/10/2018	17/10/2018	03/12/2018	FOLGIO / SHEET: 1 / 1
	FIRMA SIGN	M. Bugari	M. Bugari	G. Grosso	QUOTE SENZA INDICAZIONE DI TOLLERANZA DIMENSIONS WITHOUT TOLERANCE INDICATIONS
	MATERIALE / MATERIAL:				
	TRATTAMENTO TERMICO / HEAT TREATMENT:				
	RIVESTIMENTO SUPERFICIALE / SURFACE TREATMENT:				
	DENOMINAZIONE / DESCRIPTION:	ELETTROMANDRINO MT1073-120-ER25-380V-DX-18/18000-3KW S1-AL			
		CICLO DI VERNICIATURA / PAINTING CYCLE:			
		- SALDOCARPENTERIE / WELDED STRUCTURES:			
		- GETTI - ESTRUSI - STAMPATI / CASTINGS - EXTRUDED - MOULDED:			
		CODICE CODE: H6162H0161			
		REVISION REVISION: 0			

RIPRODUZIONE E/O DIFFUSIONE VIETATA
 REPRODUCTION AND/OR DISCLOSURE OF THE
 DRAWING IS FORBIDDEN