

ATO

Connection and Debugging Manual for All-digital AC Servo Driver

Table of Contents

Important Safety Information	1
Chapter I Installation	3
Outline Dimensions of the Servo Driver.....	3
Installation Dimensions for the Servo Driver.....	4
Installation Site.....	5
Direction and Space of Installation.....	6
Chapter II Overview of Functions	9
Basic Functions of MG -1000 Series of Servos.....	9
Type Selection of the Servo Driver.....	10
Chapter III Wiring	13
Notices.....	13
Wiring Requirements.....	13
Wiring Methods.....	13
Typical Wiring.....	14
Position Control (pulse type).....	14
Speed Control (analog value).....	15
Torque Control (analog value).....	16
Wiring Diagram for Wire Saving Motor Encoder.....	17
Wiring Diagram for the Band-type Brake of the Servo Motor.....	18
Chapter IV Interfaces	19
Definitions of Servo Control Power Supply and Heavy Current Terminal.....	19
Definitions of CN1 Interface and Control Signal Input/output.....	20
Definitions of CN2 interface and Encoder Input Signal.....	25
Principle of the Input Interface for Switching Value.....	26
4.5 Principle of the Output Interface for Switching Value.....	26
4.6 Principle of the Input Interface for Pulse Value.....	27
4.6.1 Input Mode of Pulse.....	28
Principle of the input interface of Analog Value.....	28
Principle of Encoder Interface.....	30
CN1 Output Interface for Encoder Signal (from the driver to the upper computer).....	30
CN2 Input Interface for Encoder Signal (from the servo motor to the driver).....	31
CN1 Output Interface for Z signal of the Encoder (from driver output to zeroing by the upper computer) ...	31
Chapter V Display and Operation	33
Operation Panel.....	33
Components of Parameter Structure.....	34
Status Monitoring Mode (DP- -).....	35
Parameter Modification Mode (PA--).....	38
Parameter Management Mode (EE--).....	39
JOG Operational Mode (Jr- -).....	40
Speed Trial Run Mode (Sr- -).....	40
Automatic Zeroing Mode of Analog Value (AU- -).....	41
Automatic Zeroing Mode of Encoder (CO- -).....	42
Open Loop Operation Mode (OL- -).....	42

Chapter VI Parameters	43
List of Parameters [PA Mode].....	43
Detailed Explanation of Parameters.....	45
Chapter VII Failures and Diagnosis	57
List of Alarms.....	57
Troubleshooting.....	58
Chapter VIII Debugging and Application	61
Notices to Quick Debugging.....	61
Position Control (Quick adjustment of parameters after power on).....	64
Speed Control (Quick adjustment of parameters after power on).....	66
Torque Control (Quick adjustment of parameters after power on).....	67
Dynamic Electronic Application.....	69
Debugging of Typical Problems.....	69
Chapter IX Servo Motor	71

Important Safety Information

I. Personnel Safety



- This product is a high-voltage heavy current product. Make sure that personal are within the safety area of moving mechanisms.
- Improper operation may cause accidents such as electric arc burn or electric shock, etc.
- It is not allowed to operate, wire and electrify the product without following this manual.

II. Site Safety

- This product is a high-voltage heavy current product. It is not allowed to electrify and use the product where there are combustible or corrosive gases; otherwise fire and explosion may be caused.
- It is not allowed to electrify and use the product where combustible or corrosive articles drop; otherwise fire and explosion may be caused.
- It is not allowed to use the product in the places with high humidity, moisture and metal powder; otherwise dangerous accidents such as electric shock, etc. may be caused.

III. Product and Equipment Safety



- This product is a high-voltage heavy current product. Incorrect connection may lead to damage to the product.
- PE terminal must be connected to a ground wire and make sure that the ground wire is reliably grounded.
- AC 220V power supply is suitable for this product. Do not connect an AC380V one to the servo driver.
- The U, V and W of the product should be connected with the motor. They are outputs. Do not connect them with input power supply.
- Do not connect the three-phase outputs U, V and W of the product in an incorrect sequence; because incorrect connection may lead to motor racing, damage to equipment, and overcurrent damage to the product.
- Tighten all terminals. The materials of all matching wires should be strictly selected according to power.
- Power distribution and touching of the terminals are not allowed when the driver is electrified.
- Do not touch the terminals within five (5) minutes after power down.
- It is not allowed to touch the motor and cables when the motor is in operation in order to avoid accidental injuries such as scalding and wrench, etc.

Remarks

It is hereby declared that :

- 2A/3A/5A/ shown in the manual or nameplate are the abbreviations for 20A/30A/50A.

Chapter I Installation

1.1 Outline Dimensions of the Servo Driver

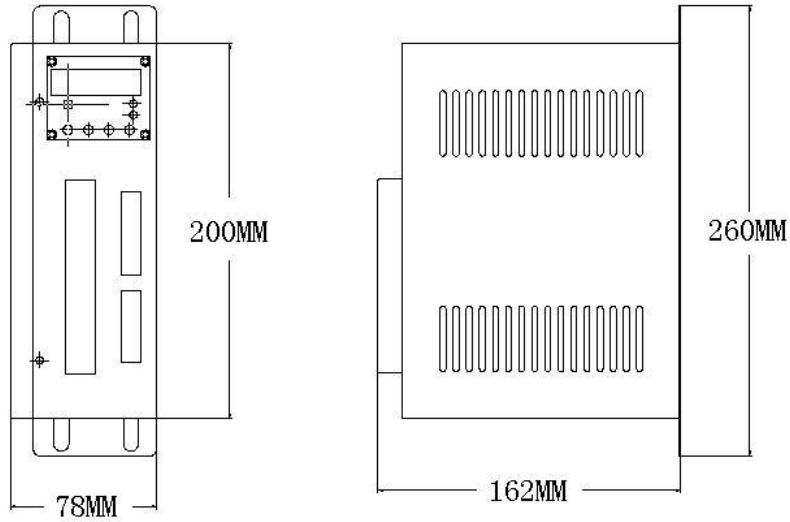

**Figure 1.1 Outline Dimensional Drawings
for the Servo Driver of 30A/30A**

1.11 Outline Dimensions of the Servo Driver

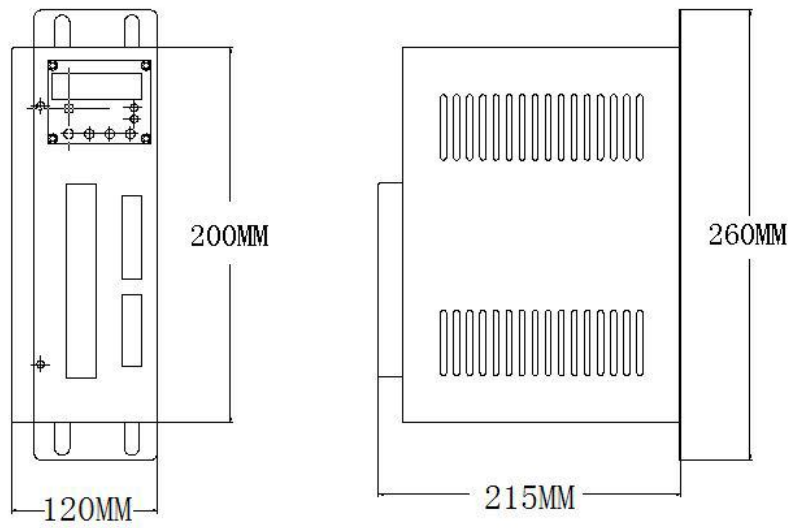

**Figure 1.2 Outline Dimensional Drawings
for the Servo Driver of 50A/75A**

1.2 Installation Dimensions for the Servo Driver

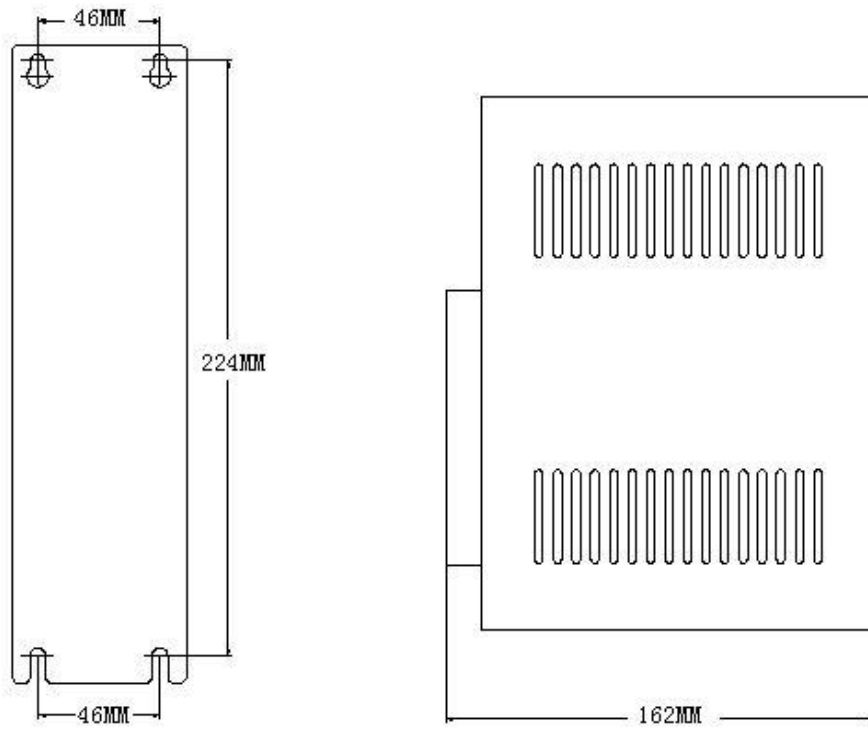

**Figure 1.11 Installation Dimensions
for the Servo Driver of 30A/30A**

1.21 Installation Dimensions for the Servo Driver

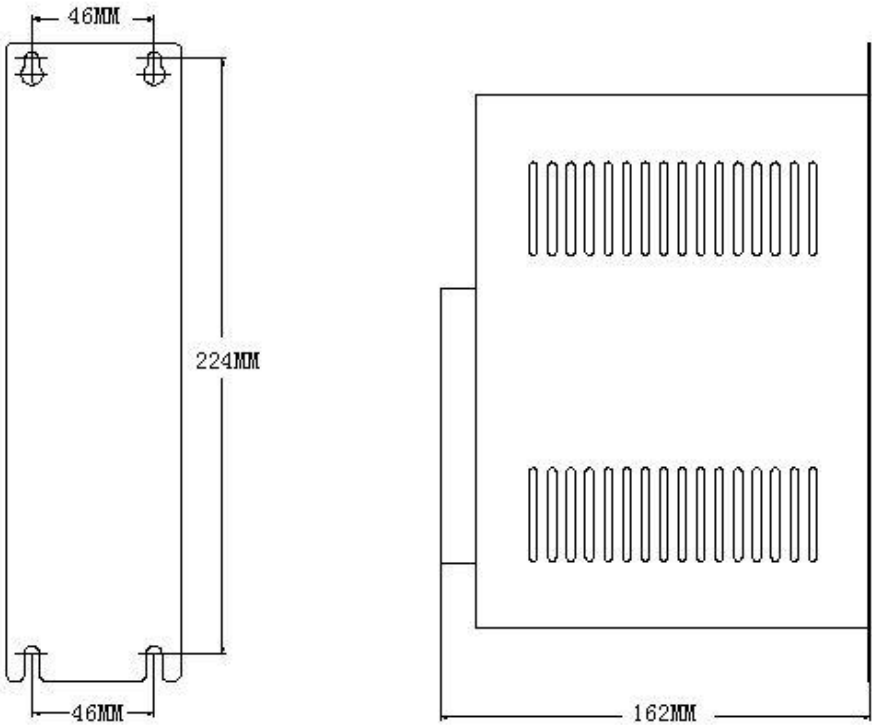

**Figure 1.21 Installation Dimensions
for the Servo Driver of 50A/75A**

Installation Site

I. To make sure that the servo driver works normally, it is necessary to ensure that the temperature around the driver is below 50°C and that the relative humidity is below 90%. The long-term safe working temperature should be below 40°C.

II. The servo driver is subject to failures when used in a severe environment with corrosive gases, high humidity, metal powder, water or processing liquids. Therefore, the working environment should be fully taken into consideration during the use and installation.

III. The vibration acceleration of the equipment which is directly or indirectly connected with the servo driver should be below 0.5G (4.9m/S²) or less in order to ensure long-term stable operation of the servo driver.

IV. The servo driver could be disturbed when it is disturbing other facilities at the same time, so attention must be paid to the wiring of heavy current and weak current during the installation of a electric cabinet or complete equipment. The servo driver is unable to work normally and also probably led to produce malfunction due to strong external disturbing signals or the serious effect on the power cord of the servo driver and control signal. At the same time control equipment such as a upper computer, etc. also cannot work stably under the disturbance of the servo driver due to poor wiring. Pay attention to install a sound magnetic ring, a wave filter and an isolation transformer, etc. at the source of the disturbance and in the places which are disturbed. Pay special attention that the wire of control signal is subject to disturbance; therefore reasonable wiring and shielding measures should be taken.

Direction and Space of Installation

- I. Pay attention to the direction of installation (See Figure 1.3).
- II. Pay attention to the spacing of installation (See Figure 1.3).
- III. Four (4) M5 bolts can fix the servo driver with a spring washer added.
- IV. The servo must be installed in a relatively closed space, with ventilation maintained in the electric cabinet and a filter screen installed at the vent to prevent the entry of dust. Clear the filter screen periodically to prevent air flow from being blocked.

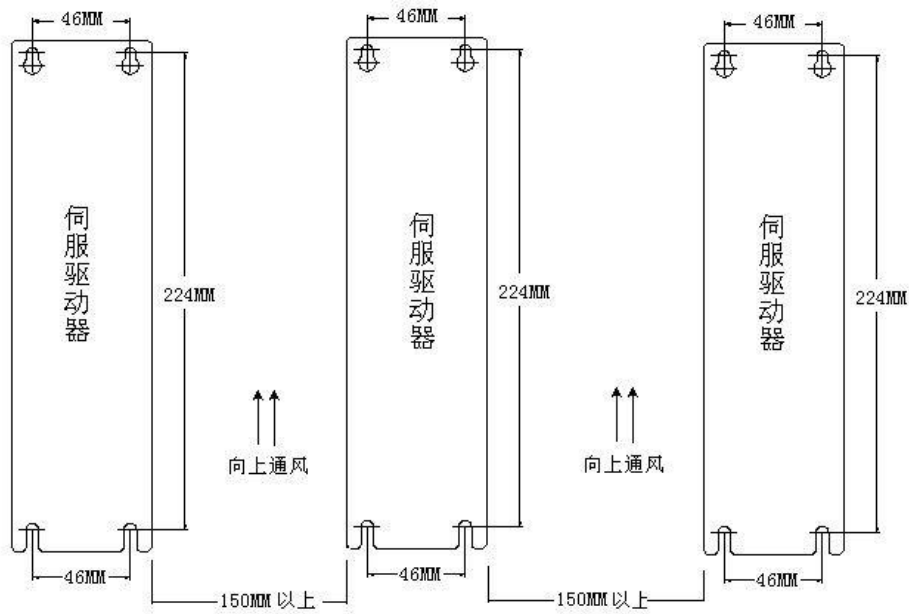

Figure 1.3 Direction of Installation

伺服驱动器 Servo Driver

向上通风 Upward ventilation

150mm 以上 above 150mm

Chapter II Overview of Functions

Basic Functions of MG -1000 Series of Servos

Type		MG -1000 (20A/30A/50A/75A)
Control power supply and main circuit power supply		Single phase or three phase AC 220V Voltage fluctuation:-15-+10%, 50/60Hz
Environment	Temperature	Working temperature: 0-55 ⁰ C Storage temperature: -40 ⁰ C-80 ⁰ C
	Humidity	No more than 90%(without condensation)
	Air index	No dust (conductive media such as metal powder, etc.) in the electric cabinet
Control mode		1. Position control 2. Speed control 3. Torque control 4. JOG operation 5. Four Internal speed control 6. Internal position control 7. Internal torque control 8. Position & speed control 9. Speed & torque control
External I/O		1. Servo enable 2. Reset 3. Position deviation reset 4. Pulse, CCW, and CW disabled. 5. Position switching 6. Speed selection 7. Zero speed clamping 8. The second reset 9. Extended functions (options) such as orientation and permissible stop, etc.
Encoder feedback		10000p/r(standard); frequency division permissible (options)
Communication mode		1. RS232(closed) 2. RS485 (closed)
Load inertia		5 times smaller than that of the motor
Monitoring function		Speed, current position, command pulse accumulation, position deviation, motor current, operation status, input and output terminals, and Z pulse signal, etc.
Protection function		Overvoltage, overcurrent, overspeed, and incorrect feedback, etc.
Alarm function		Alarms (LED flashing; red lamp on) are often given off when the servo operates abnormally.
Gain adjustment		Gain adjustment can be carried out to match motor performance when the motor operates or stops.
Adaptive motor		See Tables 2.21, 2.22 and 2.23.

Type Selection of the Servo Driver

MG-1000 B 30 L

(1) (2) (3) (4) (5)

- (1) Series: Dealour's common types of servo drivers are adaptable to multiple specifications of servo motors and industries with rich forms of database.
- (2) Feedback elements: 1000 2500C/T incremental type and wiring saving type encoders, S sine and cosine (2^{17} bi/ 2^{18} bit(131072/262144)), M multi-loop bus type ($2^{17}/2^{16}$ bit(131072/65536)), and B single-loop bus type (2^{20} bit(1048576))
- (3) Control mode: B position control, C all-function position/speed/torque control, and T special type PLC function with a touch screen
- (4) IPM module specification: 15A and 20A are called 2A for short; 30A, 3A; and 50A, 5A and 75A.
- (5) Main circuit voltage: L single phase or three phase 220V; H three phase 380V; default 220V when this voltage is omitted.

Type Code	Applicable Driver	Applicable Motor	Power (kW)	Rated Current (A)	Rated Toque (Nm)
27	MG-1000/30A	80ST-M01330	0.4	2.6	1.3
28		80ST-M02430	0.75	4.2	2.4
29		80ST-M03330	1.0	4.2	3.3
34		110ST-M02030LBF	0.6	4	2
35		110ST-M04030LBF	1.2	5	4
36		110ST-M05030LBF	1.5	6	5
37		110ST-M06020LBF	1.2	6	6
38		110ST-M06030LBF	1.8	8	6
44		130ST-M04025LBF	1	4	4
45		130ST-M05025LBF	1.3	5	5
46		130ST-M06025LBF	1.5	6	6
47		130ST-M07720LBF	1.6	6	7.7
48		130ST-M07725LBF	2.0	7.5	7.7
		130ST-M07730LBF	2.4	9	7.7
49		130ST-M10015LBF	1.5	6	10
50		130ST-M10025LBF	2.6	10	10
51		130ST-M15015LBF	2.3	9.5	15
52		130ST-M12020LBF	2.4	10	12

Table 2.21 MG -1000/30A

Type Code	Applicable Driver	Applicable Motor	Power (kW)	Rated Current (A)	Rated Toque (Nm)
0	MG-1000/50A	130ST-M07720LBF	1.6	6	7.7
1		130ST-M07725LBF	2.0	7.5	7.7
		130ST-M07730LBF	2.4	9	7.7
2		130ST-M10015LBF	1.5	6	10
3		130ST-M10025LBF	2.6	10	10
4		130ST-M15015LBF	2.3	9.5	15
5		130ST-M15025LBF	3.9	17	15
6		150ST-M12030LBF	3.6	16.5	12
7		150ST-M15025LBF	3.8	16.5	15
8		150ST-M18020LBF	3.6	16.5	18
9		150ST-M23020LBF	4.7	20.5	23
10		150ST-M27020LBF	5.5	20.5	27
11		150ST-M12020LBF	2.4	10	12
12		180ST-M17215LBF	2.7	10.5	17
13		180ST-M19015LBF	3	12	19
14		180ST-M21520LBF	4.5	16	21
15		180ST-M27010LBF	2.9	12	27
16		180ST-M27015LBF	4.3	16	27
17		180ST-M35010LBF	3.7	16	35
18	180ST-M35015LBF	5.5	24	35	
19	180ST-M48015LBF	7.5	32	48	

Table 2.22 MG-1000/50A

Type Code	Applicable Driver	Applicable Motor	Power (kW)	Rated Current (A)	Rated Toque (Nm)
0	MG-1000/75A	130ST-M07720LBF	1.6	6	7.7
1		130ST-M07725LBF	2.0	7.5	7.7
		130ST-M07730LBF	2.4	9	7.7
2		130ST-M10015LBF	1.5	6	10
3		130ST-M10025LBF	2.6	10	10
4		130ST-M15015LBF	2.3	9.5	15
5		130ST-M15025LBF	3.9	17	15
6		150ST-M12030LBF	3.6	16.5	12
7		150ST-M15025LBF	3.8	16.5	15
8		150ST-M18020LBF	3.6	16.5	18
9		150ST-M23020LBF	4.7	20.5	23
10		150ST-M27020LBF	5.5	20.5	27
11		150ST-M12020LBF	2.4	10	12
12		180ST-M17215LBF	2.7	10.5	17
13		180ST-M19015LBF	3	12	19
14		180ST-M21520LBF	4.5	16	21
15		180ST-M27010LBF	2.9	12	27
16		180ST-M27015LBF	4.3	16	27
17		180ST-M35010LBF	3.7	16	35
18	180ST-M35015LBF	5.5	24	35	
19	180ST-M48015LBF	7.5	32	48	

Table 2.23 MG-1000/75A

Chapter III Wiring

Notices

- The servo driver is a high voltage e heavy current product. Improper connection may cause damage to personnel and equipment.
- PE terminal must be connected to a ground wire and make sure that the ground wire is reliably grounded.
- AC 220V power supply is suitable for this product. Do not connect an AC380V one to the servo driver.
- The U, V and W of the product should be connected with the motor. They are outputs. Do not connect them with input power supply.
- Do not connect the three-phase outputs U, V and W of the product in an incorrect sequence; because incorrect connection may lead to motor racing, damage to equipment, and overcurrent burnout to the product.
- Tighten all terminals. The materials of all matching wires should be strictly selected according to power.
- Power distribution and touching of the terminals are not allowed when the driver is electrified.
- Do not touch the terminals within five (5) minutes after power down.
- It is not allowed to touch the motor and cables when the motor is in operation in order to avoid accidental injuries such as scalding and wrench, etc.

Wiring Requirements

- A three-phase isolation transformer is preferred for power supply.
- The required diameters of R, S, T and U, V, W, PE wires should be equal to and more than 1.5mm^2 .
- All power terminals should be cold-pressed ones, firm and reliable.
- CN1 and CN2 are high-density signal plugs that need cables with a shielding layer.
- The wires for connecting PE terminals should be yellow-green ones with a diameter equal to and more than 2.5mm^2 .

Wiring Methods

- A three-phase isolation transformer is preferred for power supply.

- The required diameters of R, S, T and U, V, W, PE wires should be equal to and more than 1.5mm².
- All power terminals should be cold-pressed ones, firm and reliable.
- CN1 and CN2 are high-density signal plugs, with both ends of the shielding layer grounded and connected with the housing.
- The wires for connecting PE terminals should be put through with the equipment housing ground wire and connected to the earth.

Typical Wiring

Position Control (pulse type)

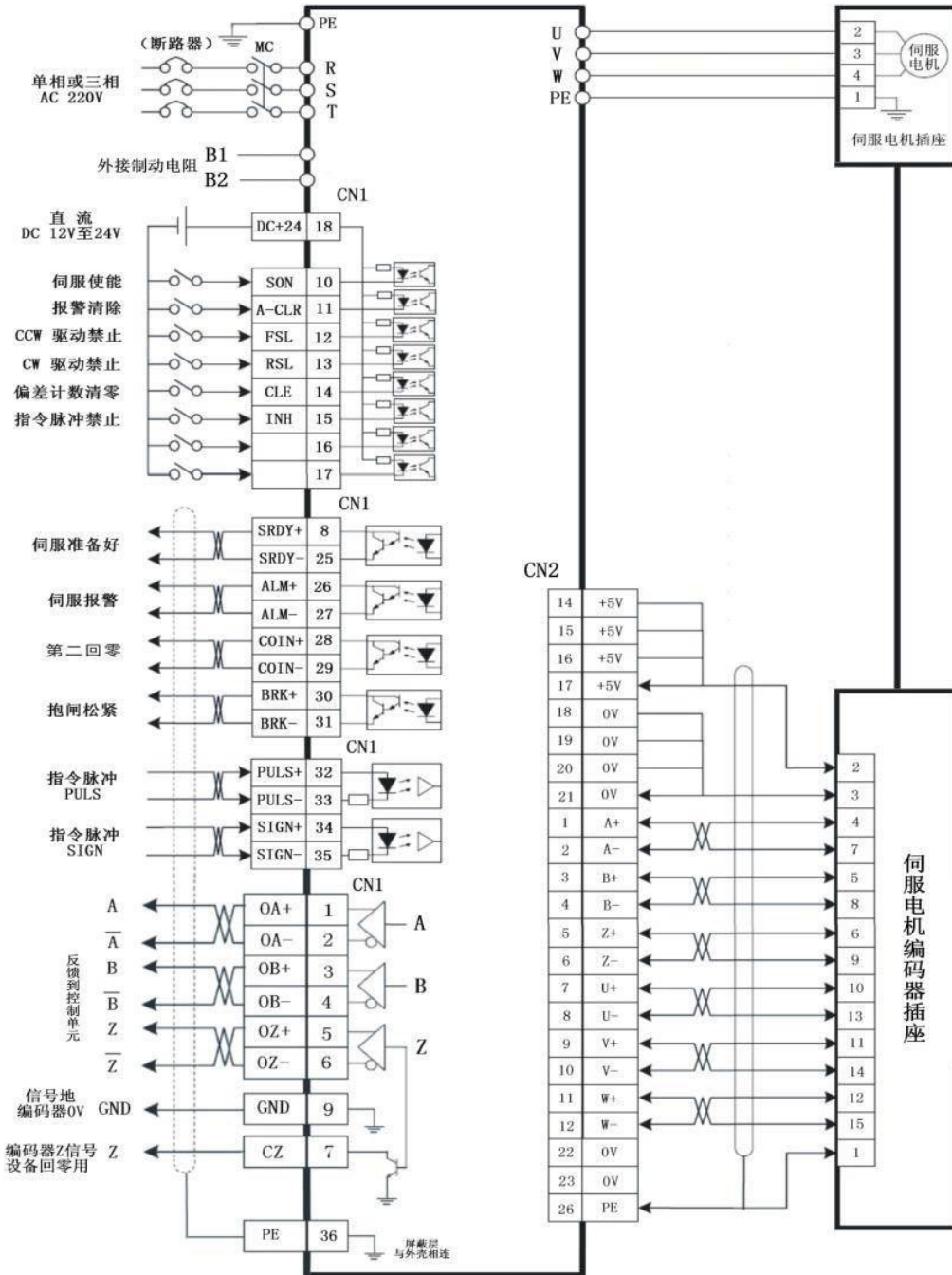

Figure 3.1 Wiring of Position Control

(断路器) (Circuit breaker)

单相或三相 AC220V Single phase or three phase AC220V

外接制动电阻 External connection to braking resistors
直流 DC12V 至 24V DC12V-24V
伺服使能 Servo enable
报警清零 Alarm reset
CCW 驱动禁止 CCW driver disabled
CW 驱动禁止 CW driver disabled
偏差计数清零 Deviation count reset
指令脉冲禁止 Command pulse disabled
伺服准备好 Servo ready
伺服报警 Servo alarm
第二回零 The second reset
伺服电机 Servo motor
伺服电机插座 Servo motor socket
抱闸松紧 Band-type brake tightness
指令脉冲 PULS Command pulse PULS
指令脉冲 SIGN Command pulse SIGN
反馈到控制单元 Feedback to control unit
信号地编码器 0V signal ground wire encoder 0V
伺服电机编码器插座 Servo motor encoder socket
编码器 Z 信号设备回零用 Encoder Z signal used for equipment reset
屏蔽层与外壳相连 The shielding layer should be connected to the housing.

Speed Control (analog value)

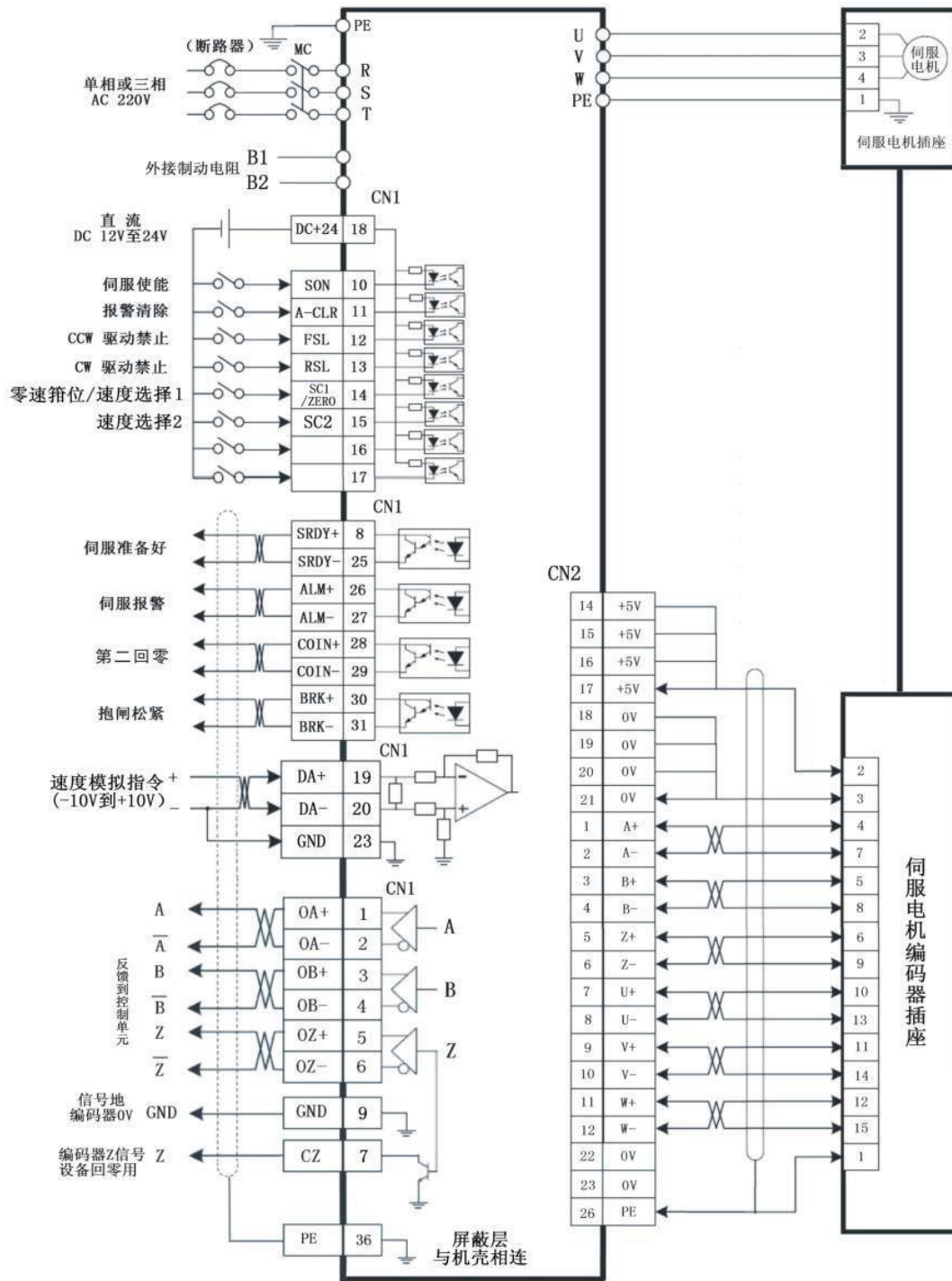

Figure 3.1 Wiring of Speed Control

(断路器) (Circuit breaker)

单相或三相 AC 220V Single phase or three phase AC 220V

外接制动电阻 External connection to braking resistors
直流 DC12V 至 24V DC12V-24V
伺服使能 Servo enable
报警清零 Alarm reset
CCW 驱动禁止 CCW driver disabled
CW 驱动禁止 CW driver disabled
零速箝位/速度选择 1 Zero speed clamping/speed selection 1
速度选择 2 Speed selection 2
伺服准备好 Servo ready
伺服 报警 Servo alarm
第二回零 The second reset
伺服电机 Servo motor
伺服电机插座 Servo motor socket
抱闸松紧 Band-type brake tightness
速度模拟指令 (-10V 到+10V) Speed analog command (-10V-+10V)
指令脉冲 PULS Command pulse PULS
指令脉冲 SIGN Command pulse SIGN
反馈到控制单元 Feedback to control unit
信号地编码器 Signal ground wire encoder
伺服电机编码器插座 Servo motor encoder socket
编码器 Z 信号设备回零用 Encoder Z signal used for equipment reset
屏蔽层与外壳相连 The shielding layer should be connected to the housing .

Torque Control (analog value)

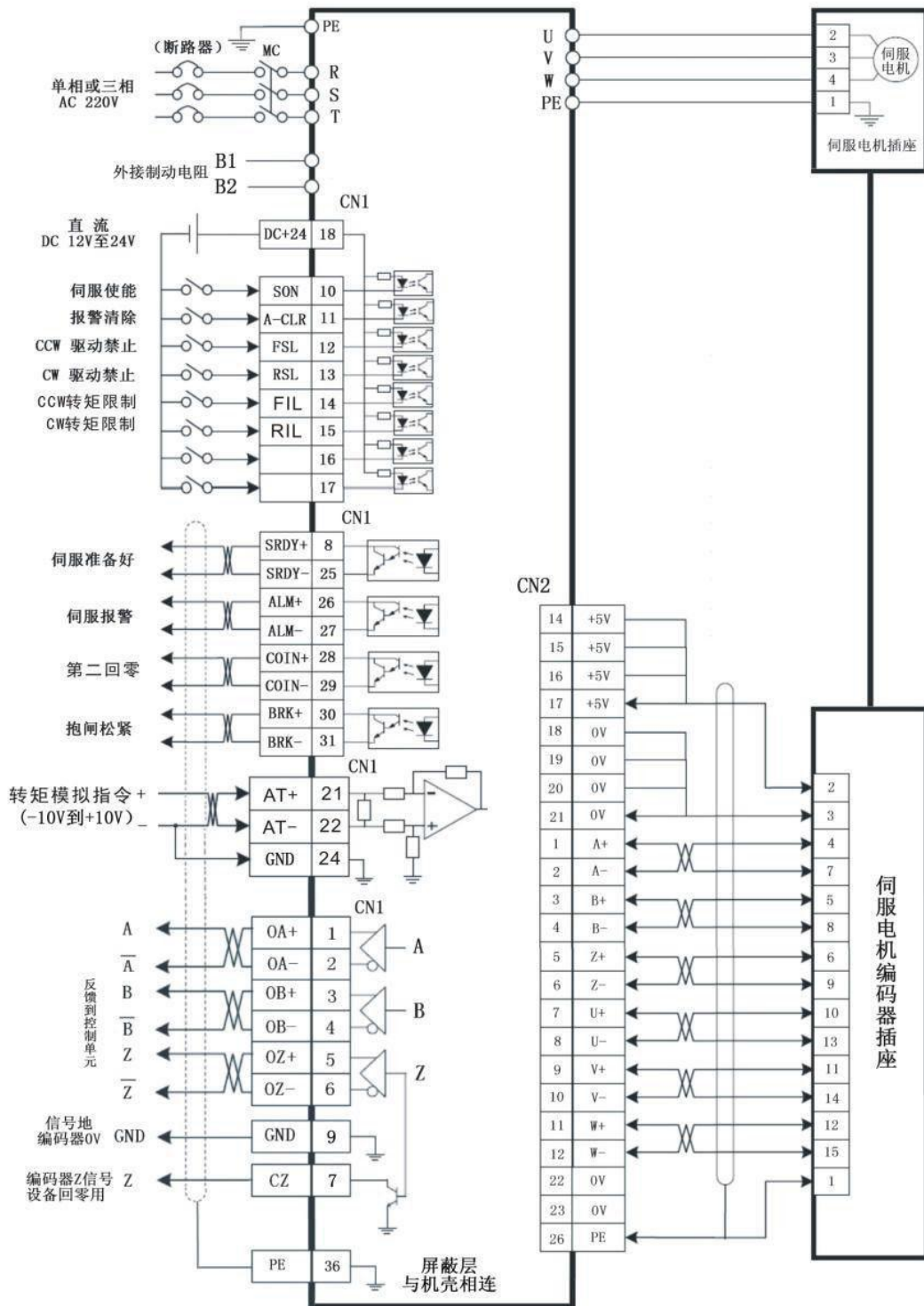

Figure 3.1 Wiring of Torque Control

(断路器) (Circuit breaker)

单相或三相 AC 220V Single phase or three phase AC 220V

外接制动电阻 External connection to braking resistors

直流 DC12V 至 24V DC12V-24V

伺服使能 Servo enable

报警清零 Alarm reset

CCW 驱动禁止 CCW driver disabled

CW 驱动禁止 CW driver disabled

CCW 转矩限制 CCW torque limit

CW 转矩限制 CW torque limit

伺服准备好 Servo ready

伺服报警 Servo alarm

第二回零 The second reset

伺服电机 Servo motor

伺服电机插座 Servo motor socket

抱闸松紧 Band-type brake tightness

转矩模拟指令 (-10V 到+10V) Torque analog command (-10V-+10V)

指令脉冲 PULS Command pulse PULS

指令脉冲 SIGN Command pulse SIGN

反馈到控制单元 Feedback to control unit

信号地编码器 Signal ground wire encoder

伺服电机编码器插座 Servo motor encoder socket

编码器 Z 信号设备回零用 Encoder Z signal used for equipment reset

屏蔽层与外壳相连 The shielding layer should be connected to the housing

Wiring Diagram for Wire Saving Motor Encoder

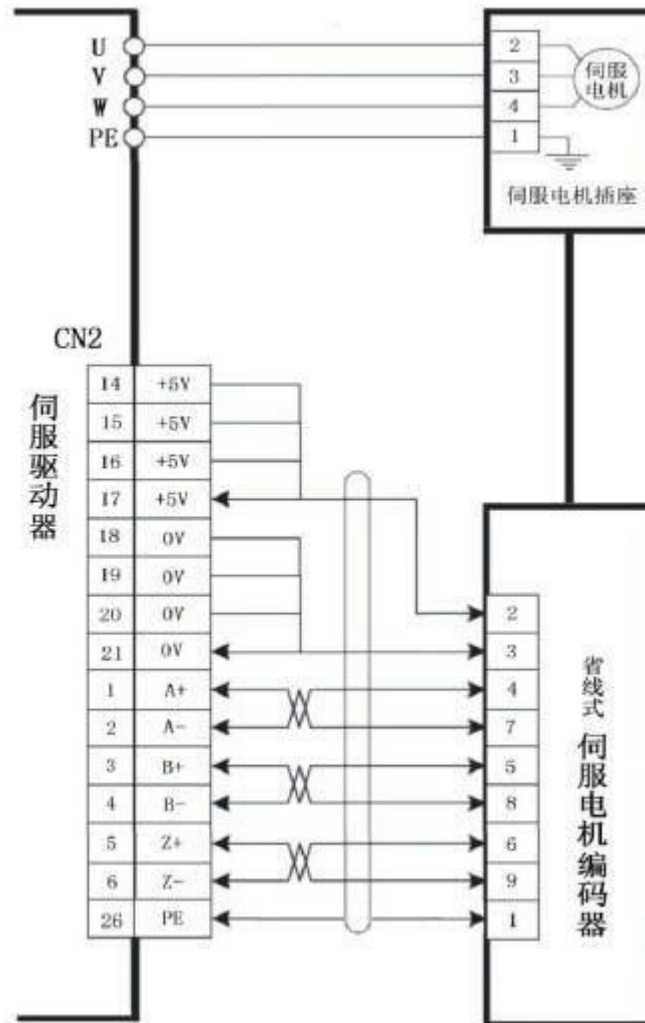

Figure 3.4 Wiring Diagram for Wire Saving Motor Encoder

伺服驱动器 Servo driver

伺服电机 Servo motor

伺服电机插座 Servo motor socket

省线式伺服电机编码器 Wire saving servo motor encoder

- A wire saving encoder should be selected for servo motors below 80 series
- A common incremental encoder should be selected for servo motors above 110 series(see Figure 3.2). Recover the automatic recognition of the driver when the adaptive motor is delivered. It is not necessary to change parameters (see Page 64).

Wiring Diagram for the Band-type Brake of the Servo Motor

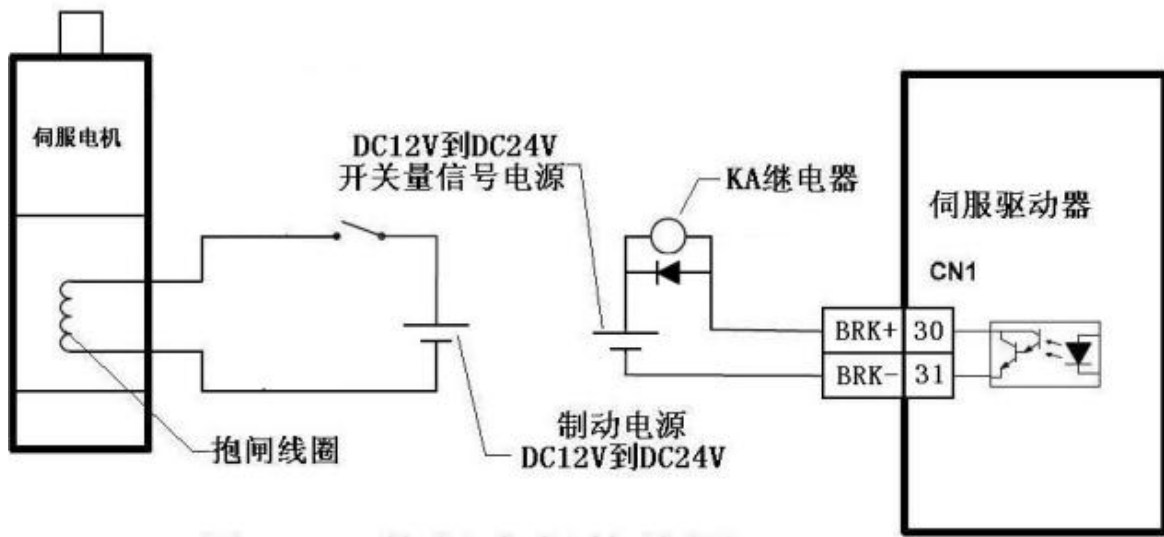

Figure3.5 Wiring Diagram for Band-type Brake Motor

伺服电机 Servo motor

抱闸线圈 Band-type brake coil

DC12V 到 DC24V 开关量信号电源 Power supply for DC12V-DC24V switching value signal

KA 继电器 KA relay

MG-1000 伺服驱动器 MG -1000 servo driver

制动电源 DC12V 到 DC24V DC12V- DC24V braking power supply

Pin No.	Pin mark	Function Description
1	DC+	DC power supply positive pole DC24V+
2	DC-	DC power supply negative pole 0V
3	PE	Housing ground wire

Table 3.1 Socket for Servo Motor Band-type Brake

- It is required that the band-type brake braking power supply should be separated from the upper computer and the DC power supply of the driver to prevent interference.
- The braking power supply for the band-type brake has positive and negative poles, which should not be connected reversely to prevent short circuit.
- In order to improve braking effect and response, a fly-wheel diode may be added at both ends of the braking coil (pay attention to the positive and negative poles of the diode).

Chapter IV Interfaces

Definitions of Servo Control Power Supply and Heavy Current

Terminal

Mark	Signal Name	Function
R	Control circuit and main circuit power supply (switched in via the isolation transformer)	R, S and T can be connected to a signal-phase or three-phase 220V 50HZ power supply. The control power supply for the driver and the power supply for the main circuit are designed in an integrated manner. Note that It should not be connected to U, V and W.
S		
T		
PE	Power supply ground wire	Connected to the equipment housing and the power supply earth of the workshop.
B1	External connection to braking resistors	Normally not used, because the driver has a built-in resistor. Externally connected braking resistors are used in case of a load with large inertia.
B2		
U	Output to the servo motor	U, V and W on the servo terminals must correspond to the ones on the servo motor without misplacement. In case of incorrect connection, the motor will pulsate, the servo will alarm, and the servo and motor could be damaged. Note that it should not connected with R, S and T.
V		
W		
PE	Motor ground wire	Connected to the PE for the housing of the servo motor.

Definitions of CN1 Interface and Control Signal Input/output



图 4.1 面对接口 CN1 36芯插头焊片看

图 4.1 面对接口 CN1 36 芯插头焊片看

Figure 4.1 Front Elevation of 36-core Plug Soldering Terminal of CN1 Interface

Pin	Mark	Signal Name	Function
18	+24V	Input power supply positive	Common end for input terminal (connected to +12V-+24V power supply)
10	SON	Servo enable	Enable terminal : When 0V is switched off, SON is OFF: The driver stops and the motor is in free state. When 0V is switched on, SON is ON: The driver works and the motor is in locking state. Commands can be received after enabling for 40MS. This signal cannot be switched on and off frequently and used for startup and shutdown of the motor.
11	A-CLR	Alarm clearance/mode switching	Alarm clearance /mode switching terminal: When 0V is switched off, A-CLR is OFF and the alarm device is in normal state or keeps an alarm state. When 0V is switched on, A-CLR is ON and the alarm is cleared. <ul style="list-style-type: none">When PA32 = 1, mode switching is effective.
12	FSL	CCW driver disabled	The servo motor is not allowed to rotate the terminal counterclockwise. <ul style="list-style-type: none">When Parameter PA20= 0, When 0V is switched off, FSL is OFF and the servo motor can rotate counterclockwise. When 0V is switched on, FSL is ON and the servo motor is not allowed to rotate counterclockwise. <ul style="list-style-type: none">Have the same function with a limit switch; PA55 can be set to normal open or normal close.Used in combination with Parameter PA20. When FSL

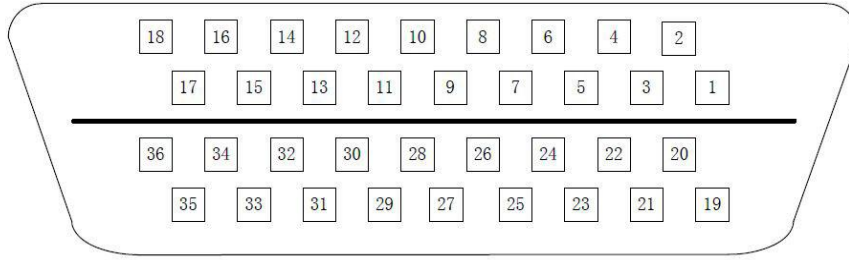
			is 1, this function is shielded.
--	--	--	----------------------------------

13	FSR	CW driver disabled	<p>The servo motor is not allowed to rotate the terminal clockwise.</p> <ul style="list-style-type: none"> • When Parameter PA20 = 0, When 0V is switched off, FSR is OFF and the servo motor can rotate clockwise. • When 0V is switched on, FSR is ON and the servo motor is not allowed to rotate clockwise. • Have the same function with a limit switch; PA55 can be set to normal open or normal close. • Used in combination with Parameter PA20. When FSR is 1, this function is shielded.
14	CLE	Deviation counter reset	<p>Reset Terminal 1 of the position deviation counter:</p> <ul style="list-style-type: none"> • Under the mode of position control, namely when PA4 = 0, When 0V is switched off, CLE is OFF and the counter keeps displaying the value. • When 0V is switched in, CLE is ON and the counter resets.
	SC1	Terminal 1 for selection of internal speeds	<p>Terminal 1 for selection of internal speeds:</p> <ul style="list-style-type: none"> • The mode of the internal speed when PA4 = 1 and PA22 = 0: Four types of internal speeds are selected via the combination of SC1 (P in 14) and SC2(Pin 15) as well as the make-and-break of 0V. • SC1 OFF, SC2 OFF: internal speed 1; • SC1 ON, SC2 OFF: internal speed 2; • SC1 OFF, SC2 ON: internal speed 3; • SC1 ON, SC2 ON: internal speed 4; • Four types of speeds can be modified via PA24, PA25, PA26, and PA27.
	ZERO	Zero speed clamping	<p>Reset terminal for the analog value of speed command:</p> <ul style="list-style-type: none"> • The mode of the external analog speed when PA4 = 1 and PA22 = 1: ZERO is OFF when 0V is switched off, and the speed command is an analog input value. • ZERO is ON when 0V is switched on, and the speed command is reset to zero.
	CCW	0-+10 positive	<ul style="list-style-type: none"> • External analog value control PA22=2; 0-+10V

		rotation	controls positive rotation .
	RIL	CCW torque limit	<p>During torque control, the motor is limited to rotate the terminal clockwise.</p> <p>When 0V is switched on, the value of Parameter PA38 is effective; otherwise it is ineffective.</p> <ul style="list-style-type: none"> • During torque control, Parameter PA34 plays a limiting role all the time.

15	INH	Command pulse disabled	<p>The command pulse disabled terminal:</p> <ul style="list-style-type: none"> • The mode of external position control when Parameter PA4= 0: <p>When 0V is switched off, INH is OFF and the command pulse input is effective.</p> <p>When 0V is switched on, INH is ON and the command pulse input is disabled.</p>
	SC2	Terminal 2 for selection of internal speeds	<p>Terminal 2 for selection of internal speeds:</p> <ul style="list-style-type: none"> •The mode of the internal speed when PA4= 1 and PA22 = 0: <p>Four types of internal speeds (set via PA24 -PA27) are selected via the combination of SC1 (Pin 14) and SC2 (Pin 15) as well as the make-and-break of 0V.</p> <p>SC1 OFF, SC2 OFF : internal speed 1; SC1 ON, SC2 OFF : internal speed 2; SC1 OFF, SC2 ON: internal speed 3; SC1 ON, SC2 ON: internal speed 4;</p>
	FIL	CCW Torque limit	<p>During torque control, the motor is limited to rotate the terminal counter clockwise.</p> <p>When 0V is switched on, the value of Parameter PA38 is effective; otherwise it is ineffective.</p> <ul style="list-style-type: none"> •During torque control, Parameter PA35 plays a limiting role all the time.
	CW	0-+10 Reverse rotation	<ul style="list-style-type: none"> •External analog value control PA22=2; 0-+10V controls forward rotation.
8	SRDY+	The servo is ready for output.	<p>Example: Pin 8 is connected to +24V and Pin 25 to the upper computer.</p> <p>When the servo is in normal state, the upper computer is able to receive the electrical level of +24V.</p> <p>When the servo alarms, +24V is disconnected from the</p>
25	SRDY-		

			<p>upper computer.</p> <p>Example: Pin 25 is connected to 0V and Pin 8 to the upper computer.</p> <p>When the servo is in normal state, the upper computer is able to receive the electrical level of 0V.</p> <p>When the servo alarms, 0V is disconnected from the upper computer (normal close).</p> <ul style="list-style-type: none">•Electrical level inversion or normal open/ normal close switching can be done via Parameter PA57.
--	--	--	---

Pin	Mark	Signal Name	Function
26	ALM+	Servo alarm output	<p>Example: Pin 26 is connected to +24V and Pin 27 to the upper computer.</p> <p>When the servo alarms, the upper computer is able to receive the electrical level of +24V.</p> <p>When the servo is in normal state, +24V is disconnected from the upper computer.</p> <p>Example: Pin 27 is connected to 0V and Pin 26 to the upper computer.</p> <p>When the servo is in normal state, the upper computer is able to receive the electrical level of 0V.</p> <p>When the servo alarms, 0V is disconnected from the upper computer (normal close).</p> <ul style="list-style-type: none"> • Electrical level inversion or normal open/ normal close switching can be done via Parameter PA57.
27	ALM-		
28	COIN+	The second reset (used for Siemens) Positioning done or speed reached	<p>Example: Pin 28 is connected to +24V and Pin 29 to the upper computer.</p> <p>When positioning is done, speed is reached, or in zero position , the upper computer is able to receive the electrical level of +24V; otherwise +24V is disconnected from the upper computer.</p> <p>Example: P in 29 is connected to 0V and Pin 28 to the upper computer.</p> <p>When positioning is done, speed is reached, or in zero position , the upper computer is able to receive the electrical level of 0V; otherwise 0V is disconnected from the upper computer.</p> <ul style="list-style-type: none"> • Electrical level inversion or normal open/ normal close switching can be done via Parameter PA57. • Primarily used for reset of Siemens 801 and 802 numeric controls in the machine tool industry.
29	COIN-		
30	BRK+	Mechanical brake	<p>The output end of the band -type brake switch:</p> <p>Example: Pin 30 is connected to +24V and Pin 31 to</p>
31	BRK-		

		(band-type brake) tightness	<p>the positive pole of the relay coil.</p> <p>After the motor is enabled, the coil of the intermediate relay is able to receive the electrical level of +24V; otherwise +24V is disconnected from the relay.</p> <p>Example: P in 31 is connected to 0V and Pin 30 to the negative pole of the relay coil.</p> <p>After the motor is enabled, the coil of the intermediate relay is able to receive the electrical level of 0V; otherwise 0V is disconnected from the relay.</p> <ul style="list-style-type: none"> • Electrical level inversion or normal open/ normal close switching can be done via Parameter PA57. • PA47 is used to set delayed switching on of the band-type brake. • PA48 is used to set enabled delayed switching off.
--	--	-----------------------------	---

32	PULS-		
33	SIGN-	SIGN input for command pulse	
34	SIGN-		
19	DA+	Analog speed command input	Input terminal for external analog speed command The input range of speed control analog command is -10V-+10V.
20	DA-		
23	GND	Analog input ground wire	Analog input ground wire
21	AT+	Analog torque command input	Input terminal for external analog torque command The input range of speed control analog command is -10V-+10V.
22	AT-		
24	GND	Analog input ground wire	Analog input ground wire

1+	OA+	Encoder's Phase	The difference of ABZ signal of the encoder is output and fed back by the driver to the upper computer. +'
2p	OA+	Ap	
3p	OB+	Encoder's Phase	
4p	OB+	B+	
5p	OZ+	Encoder's Phase	
6+	OZ+	Zp	
7+	CZ+	Encoder's Z-phase signal is output by the open circuit of the collecting electrode. +>	Used for setting to find out the zero point. There is only one Z-phase signal when the motor rotates for one circle. • Encoder's Z-phase signal is output by the open circuit of the collecting electrode. CZ is ON (electrified) when the encoder's Z-phase signal is output; otherwise CZ outputs OFF. +>
9p	GND+	Encoder's OV p	Encoder's OV (the common ground wire can share the same ground wire with Pin 36) . '
36+	PE+	The ground wire for the shielding layer +>	To be connected with the housing Improve anti-interference by short circuiting PE with the digital ground wire to ensure reliable grounding, according to different upper computers.p

Definitions of CN2 interface and Encoder Input Signal



图 4.2 面对 CN2 26芯插头焊片看

图 4.2 面对 CN2 26 芯插头焊片看

Figure 4.2 Front Elevation of 26-core Plug Soldering Terminal of CN2 Interface

	Mark	Signal Name	Function
14,15,16,17	+5V	+5V power supply for the encoder	To provide power supply for the encoder (via shielded cables).
18,19,20,21,22,23	0V	0V ground wire for the encoder	
1	A+	A+ input for the encoder	To be connected to A+ of the servo motor.
2	A-	A- input for the encoder	To be connected to A- of the servo motor.
3	B+	A+ input for the encoder	To be connected to B+ of the servo motor.
4	B-	A- input for the encoder	To be connected to B- of the servo motor.
5	Z+	A+ input for the encoder	To be connected to Z+ of the servo motor.
6	Z-	A- input for the encoder	To be connected to Z- of the servo motor.
7	U+	A+ input for the encoder	To be connected to U+ of the servo motor.
8	U-	A- input for the encoder	To be connected to U- of the servo motor.
9	V+	A+ input for the encoder	To be connected to V+ of the servo motor.
10	V-	A- input for the encoder	To be connected to V- of the servo motor.
11	W+	A+ input for the encoder	To be connected to W+ of the servo motor.
12	W-	A- input for the encoder	To be connected to W- of the servo motor.

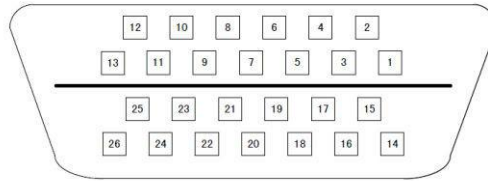
26	PE	The ground wire for the shielding layer	To be connected with the housing. Improve anti-interference by short circuiting PE with the digital ground wire to ensure reliable grounding, according to different upper computers.
----	----	---	---

Principle of the Input Interface for Switching Value

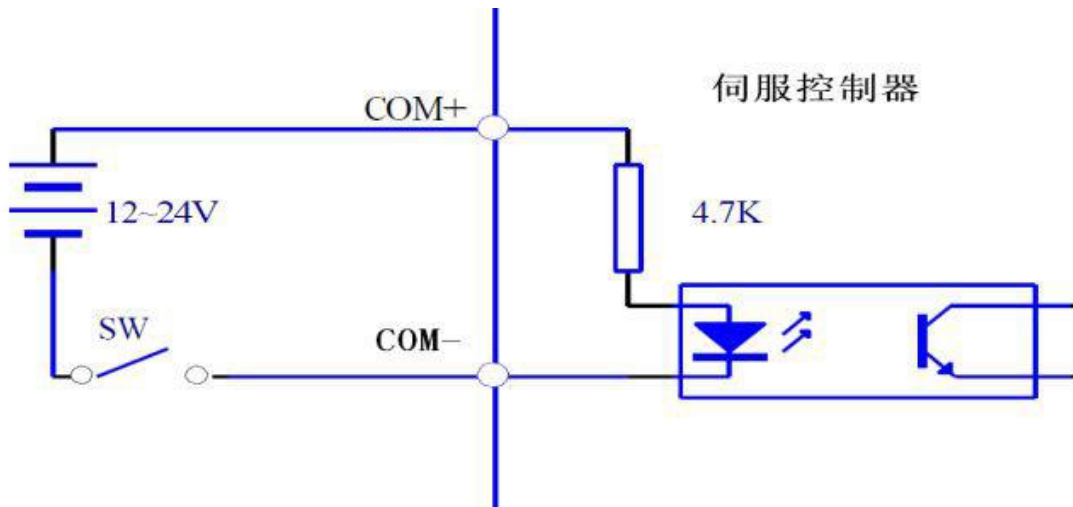

Figure 4.3-a Input Interface for Switching Value

Servo controller

- The input interface should be externally connected to a power supply of DC12V-24V with a current equal to and more than 105MA.
- Inverse connection of the positive and negative poles may damage the driver and make it unable to work normally.

Principle of the Output Interface for Switching Value

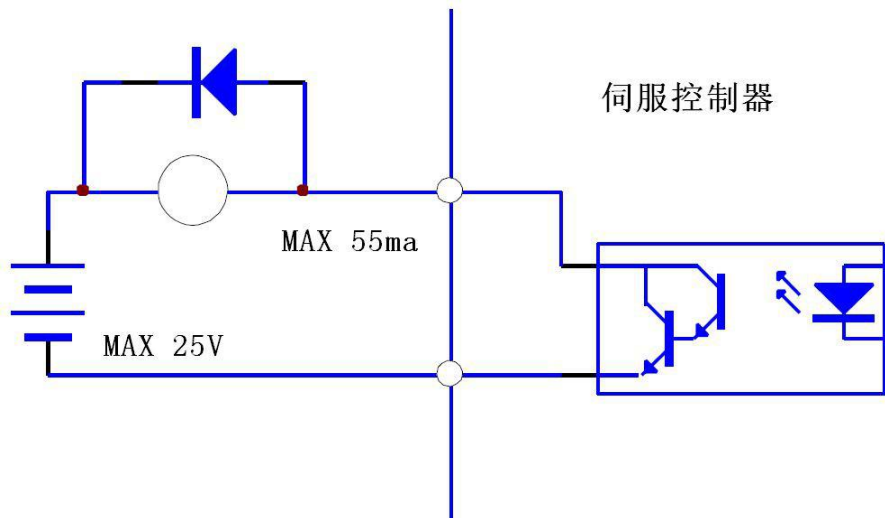

Figure 4.3-b Output Interface for Switching Value

Servo controller

- The maximum output voltage is 25V and the maximum output current is equal to and less than 55MA.

- Inverse connection of the positive and negative poles may damage the driver and make it unable to work normally.
- The output load is an inductive component which should be inversely connected in parallel with a fly-wheel diode (Make sure that the poles are properly connected; otherwise the driver will be damaged. Inverse connection of the poles is equal to short circuit).

Principle of the Input Interface for Pulse Value

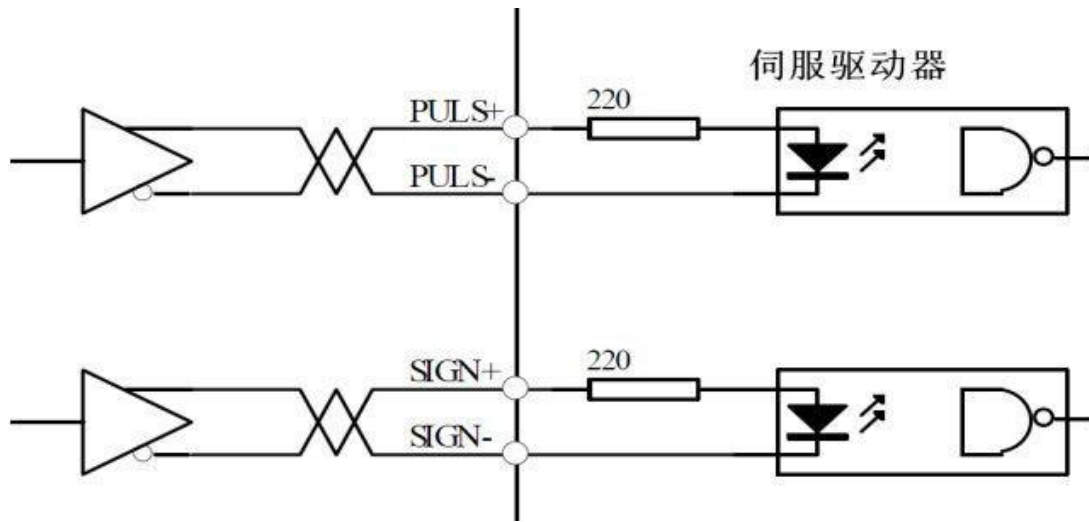

Figure 4.4-a Differential Output Mode of Pulse

Servo controller

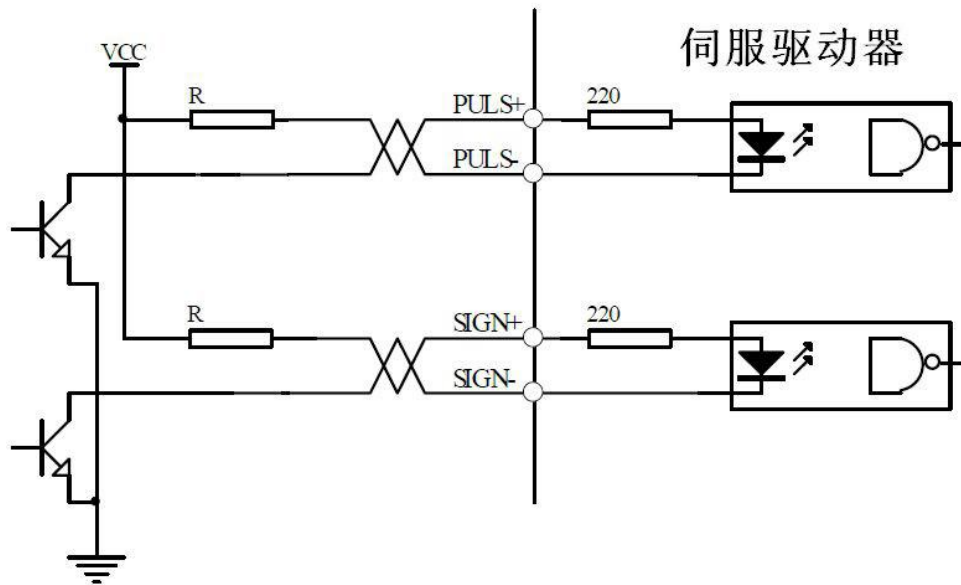

Figure 4.4-b Single-ended Output Mode of Pulse

Servo controller

- The differential output mode of pulse is relatively reliable, so it is suggested to use AM26LS31 and the like that are similar to a RS422 line driver.
- The power supply is provided externally under the single-ended output mode and the working frequency will lower. There are empirical data below:

Input voltage Vcc	Series resistance R
24V	1.4K-2K
12V	500Ω-820Ω
5V	80Ω-120Ω

4.6.1 Input Mode of Pulse

Input Mode of Pulse	CCW Operation	CW Operation	Parameter Selection
Pulse + direction			Parameter PA14=0
CCW pulse CW pulse			Parameter PA14=1
AB-biphase orthogonal pulse			Parameter PA14=2

Principle of the input interface of Analog Value

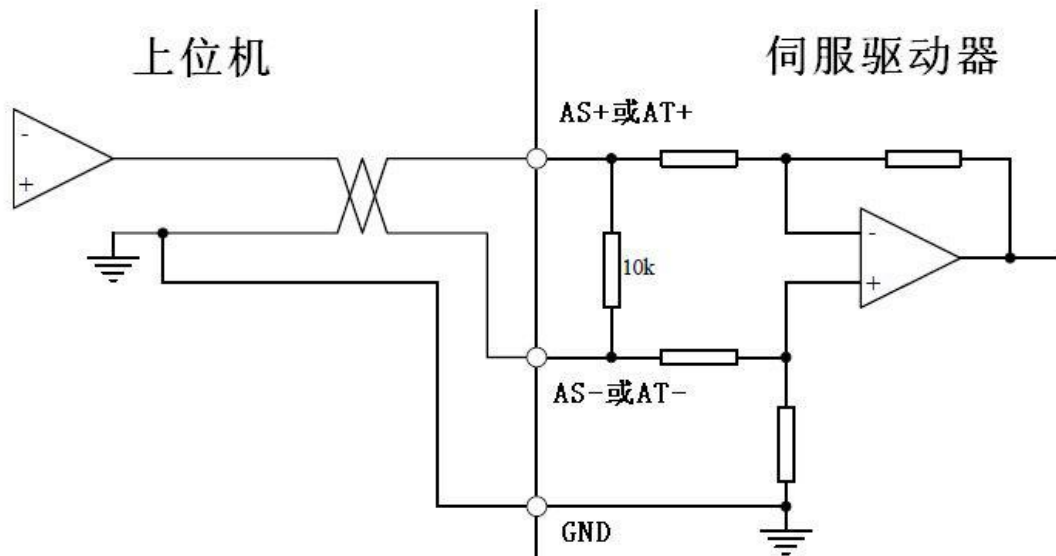

Figure 4.5-a Interface for Analog Differential Input

上位机 Upper computer

伺服驱动器 Servo driver

AS+或 AT+ AS+ or AT+

AS-或 AT- AS- or AT-

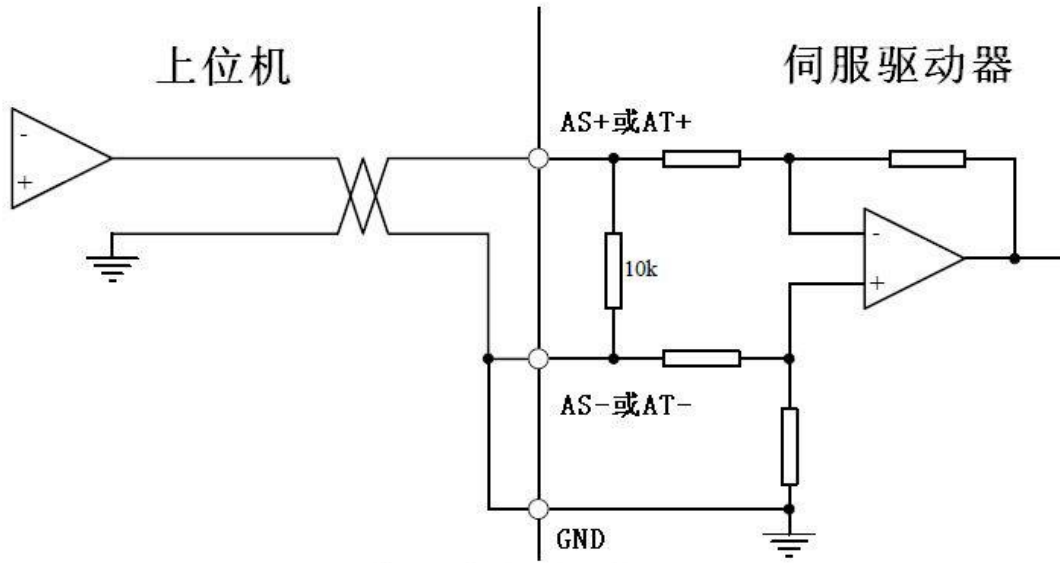

Figure 4.5-b Interface for Analog Single-ended Input

上位机 Upper computer

伺服驱动器 Servo driver

AS+或 AT+ AS+ or AT+

AS-或 AT- AS- or AT-

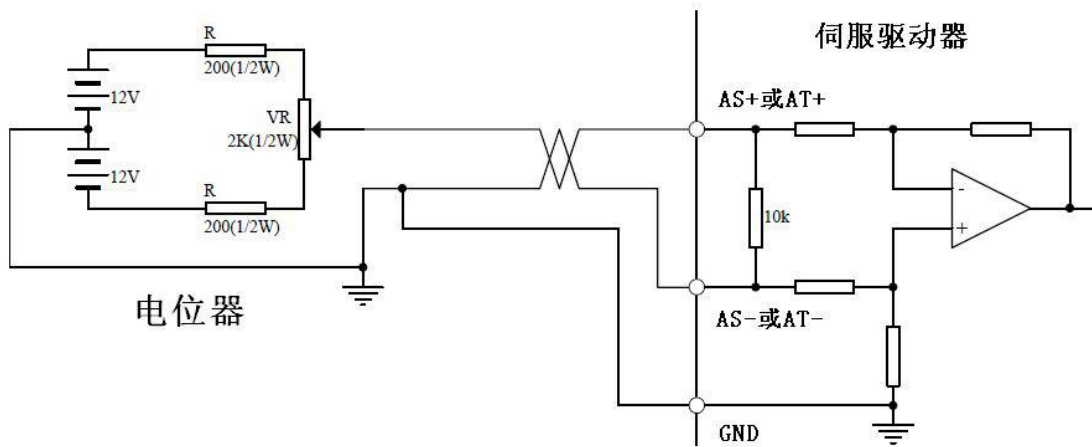

Figure 4.5-c Input Interface for Analog Differential Potentiometer

电位器 Potentiometer

伺服驱动器 Servo driver

AS+或 AT+ AS+ or AT+

AS-或 AT- AS- or AT-

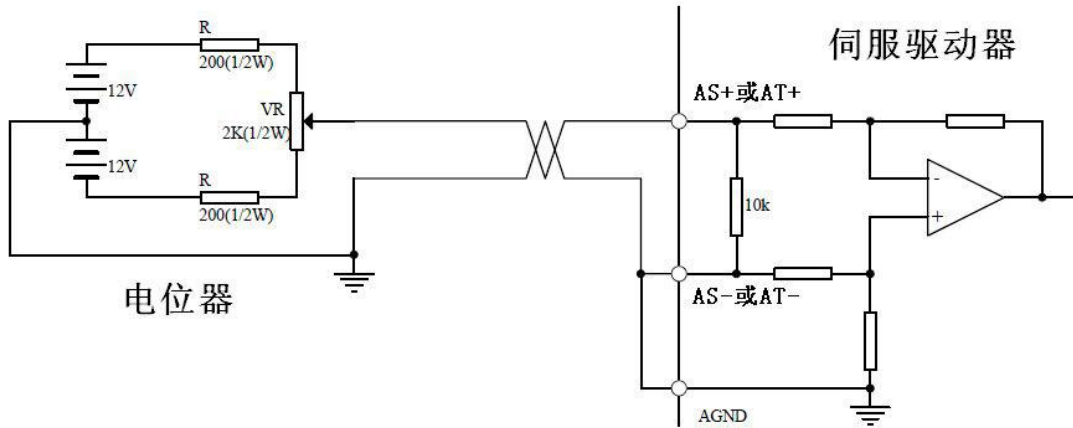

Figure 4.5-d Input Interface for Analog Single-ended Potentiometer

电位器 Potentiometer

伺服驱动器 Servo driver

AS+或 AT+ AS+ or AT+

AS-或 AT- AS- or AT-

- The input voltage of the analog value should not exceed the range of -10V+10V; otherwise the driver will be damaged.
- The analog value has a deviation indeed, because wires and the interface circuit, etc, weaken and are interfered. It is suggested that a cable with a shielding layer be used for connection with its both ends grounded. Parameter PA49 can be used to set the threshold voltage (unit: rpm).
- The analog value has a deviation indeed, so it must be adjusted. Parameter PA45 can be used to make compensate for the deviation value.

Principle of Encoder Interface

4.8.1 CN1 Output Interface for Encoder Signal (from the driver to the upper computer)

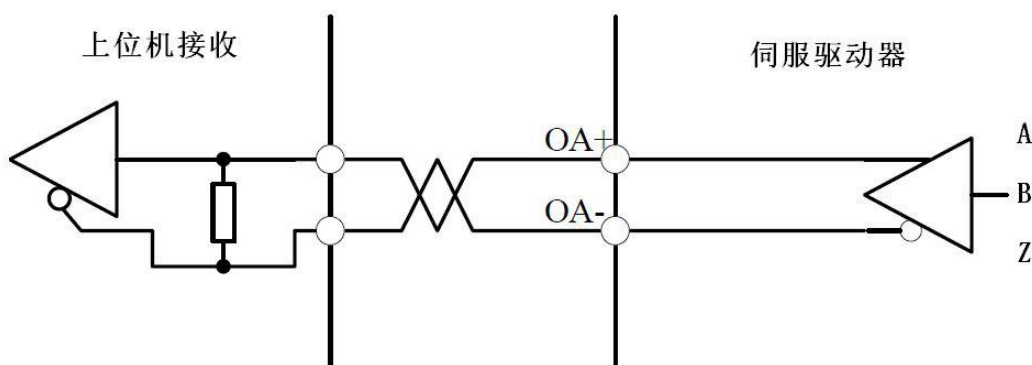

Figure 4.6 CN1 Output Interface for Encoder

上位机接收 Upper computer receiving

伺服驱动器 Servo driver

- The signal of the encoder passes the differential driver AM26LS31 and is not an non-isolated output.
- The upper computer can receive the signal via AM26LS32 or a high-speed photocoupler.

CN2 Input Interface for Encoder Signal (from the servo motor to the driver)



图 4.7 CN2 光电编码器输入接口

Figure 4.7 CN2 Input Interface for Photoelectric Encoder

伺服电机编码器 Servo motor encoder

伺服驱动器 Servo driver

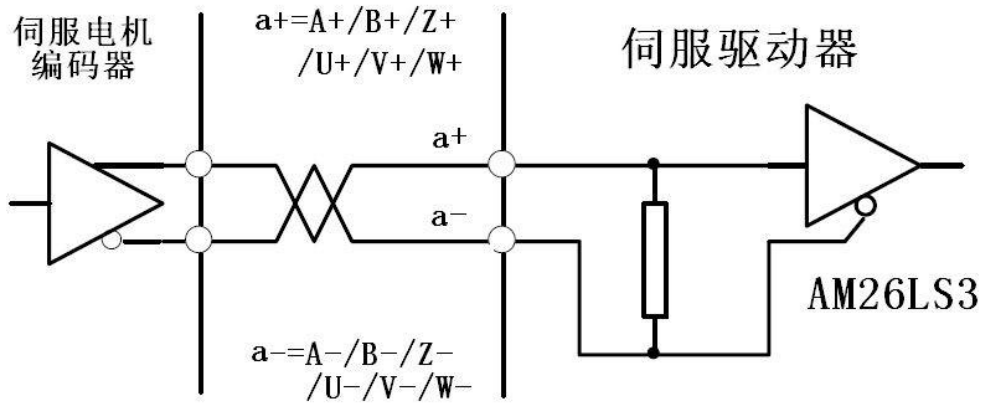
CN1 Output Interface for Z signal of the Encoder (from driver output to zeroing by the upper computer)

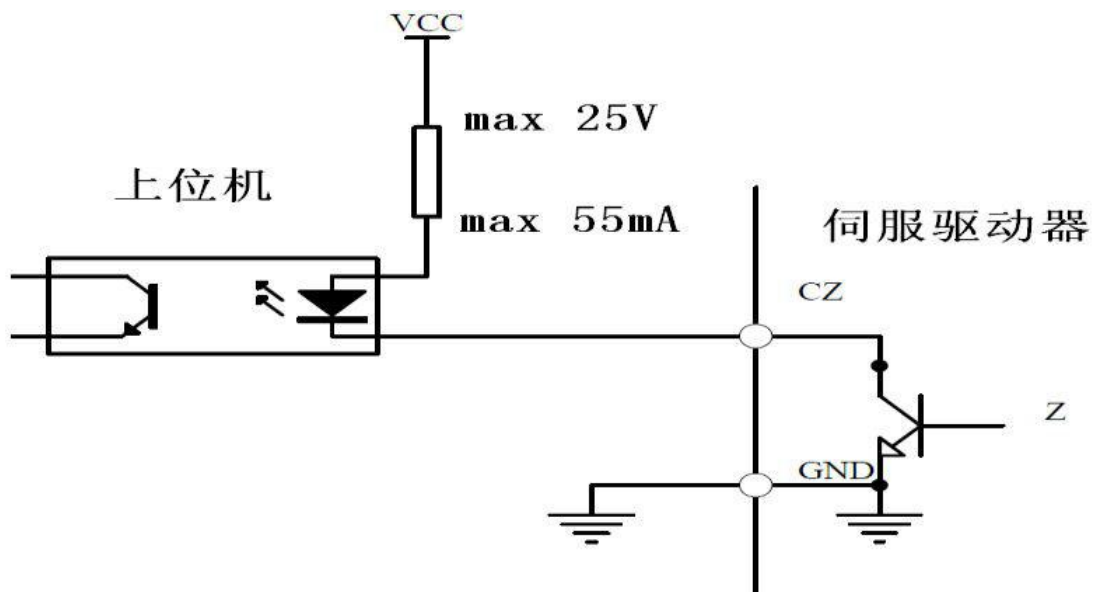

Figure 4.8 CN 1 Output Interface for Z Signal of Photoelectric Encoder

上位机 Upper computer

伺服驱动器 Servo driver

- The Z signal is a non-isolated signal which is output by the open circuit of the collecting electrode. The Z

signal of the encoder has conduction but no cut-off.

- The Z signal should be received via a high-speed photocoupler.

Remarks

Chapter V Display and Operation

Operation Panel

The operation panel is comprised of six LED digital tube displays and four keys \uparrow \downarrow \leftarrow and \rightarrow Enter, one red Alm Alm, and one green lamp, which are used to display all kinds of statuses of the system and to set parameters.



图 5.1 操作面板

Figure 5.1 Operation Panel

Operations are layered operations as follows:

\leftarrow refers to the back, exit and cancel of a layer;

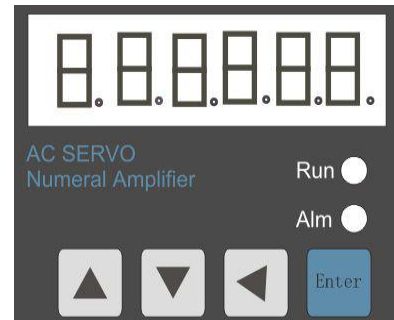
\rightarrow refers to the advance, entry and confirmation of the hierarchy

\uparrow and \downarrow refers to increasing or decreasing a sequence number or a value.

When the red indicating lamp Alm is on, it means that there is an alarm; and the alarm is displayed on the digital tube.

When the green indicating lamp Run , it means the motor is in enable working state.

- When the decimal points at the lower right corner of the digital tube, it means a parameter is being modified.
- When the red indicating lamp Alm is on and the alarm number —Err--xx || is flashing, there is a driver alarm. Cut off the power supply and find out the cause of the alarm.

Components of Parameter Structure

The first layer is used for mode selection. There are totally seven modes. Press \leftarrow to return the main menu. Use

\uparrow and \downarrow to select a mode. Press \rightarrow Enter to enter the second layer of a selected mode. Press \leftarrow to go back to the first layer.

DP--	-----	Status monitoring mode
PA--	-----	Parameter modification mode
EE--	-----	
SR--	-----	Speed trial run mode
JR--	-----	JOG operation mode
AU--	-----	Analog value auto-zeroing
CO--	-----	Encoder zeroing mode
OL--	-----	Open-circuit operation mode

Status Monitoring Mode (DP- -)

DP-SPD	Motor speed	→	1000	1000 rpm
D	Current position lower 5 digit	→	P80829	80829 pulses
P	Current position higher 5 digit	→	P	110000 pulses
DP-CPO	Position command lower 5 digit	→	C81410	81410 pulses
DP-CPO	Position command higher 5 digit	→	C	220000 pulses
DP-EPO	Position deviation lower 5 digit	→	9	0 pulses
DP-EPO	Position deviation higher 5 digit	→	10	0
DP-TRQ	Motor torque (%)	→	T 60	Motor torque(70%)
DP--I	Motor current(A)	→	1 4.5	Motor current(4.5A)
DP-LSP	Z pulse count	→	80829	the number of Z pulses
CNE	Current control mode	→	CNE 0	Control mode 0 DP-FRQ
	command frequency	→	r 1000	1000rpm
DP-CS	Speed command	→	35	Speed command 35rpm
DP-Ct	Torque command	→	70	Torque command 20%
DP-APO	Rotor absolute position	→	A 3325	3125 pulses
DP--IN	Input terminal status	→	lnhllhl	Input terminal status
DP-Out	Output terminal status	→	outllhl	Output terminal status DP-
COD	Encoder input signal	→	cbdlh	Encoder signal
DP-RN	Operation status	→	m-on	Motor is running DP-
ERR	Alarm code	→	Err 9	Alarm Code 9

Table 5.2 Table of Monitoring

1. The input pulse value is a pulse that is magnified by an input electronic gear.
2. The unit of the pulse value is the unit of the internal pulse of the servo, 10000 pulses per revolution.
3. Display of Operation Statuses
 - CN-OFF || means that the heavy current for the servo is not switched on.
 - CN-CH || means that the heavy current for the servo is switched on, but enabling is not switched on.
 - CN-ON || means that the heavy current for the servo and the enabling are switched on and that the servo is in operation state.
4. The absolute position of the rotor in one revolution refers to the position of the rotor relative to the stator in one revolution. One revolution is a cycle with a range of 0-9999. The electronic gear ratio is not used in calculations.
5. The display of the input terminal status is shown in the following figure:

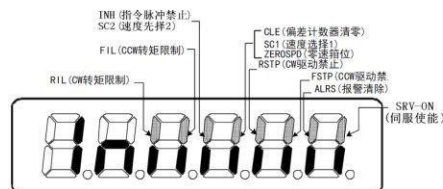

Figure 5.2 Display of Input Terminal Status

INH (指令脉冲禁止) INH (command pulse disabled)
 SC2 (速度选择 2) SC2 (speed selection 2) FIL
 (CCW 转矩限制) FIL (CCW torque limit) RIL (CW
 转矩限制) RIL (CW torque limit) CLE (偏差计数器
 清零) CLE (deviation counter reset) SC1 (速度选择
 1) SC1 (speed selection 1)
 ZEROSPD (零速箝位) ZEROSPD (zero position clamping) RSTP
 (CW 驱动禁止) RSTP (CW driver disabled) FSTP
 (CW 驱动禁止) FSTP (CW driver disabled) ALRS (报警 清除)
 ALRS (Alarm clearance)
 SRV-ON (伺服使能) SRV-ON (servo enable)

(When strokes lighten and there is signal input, the input terminal is ON; when it goes out, the input terminal is disconnected to OFF.)

6. The display of the output terminal status is shown in the following figure:

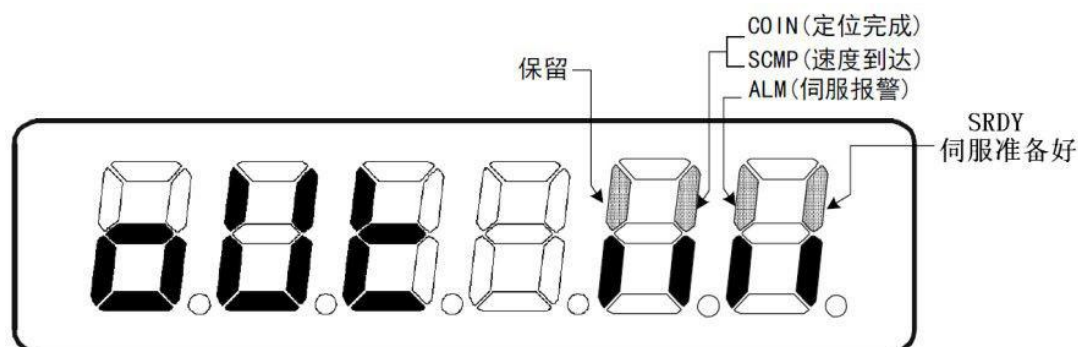

Figure 5.3 Display of Input Terminal Status

(When strokes lighten and there is signal input, the input terminal is ON; when it goes out, the input terminal is disconnected to OFF.)

保留 Retained
 COIN (定位完成) COIN (positioning done)
 SCMP (速度到达) SCMP (speed reached)
 ALM (伺服报警) ALM (servo alarm)
 SRDY 伺服准备好 SRDY (servo ready)

7. The display of the encoder status is shown in the following figure:

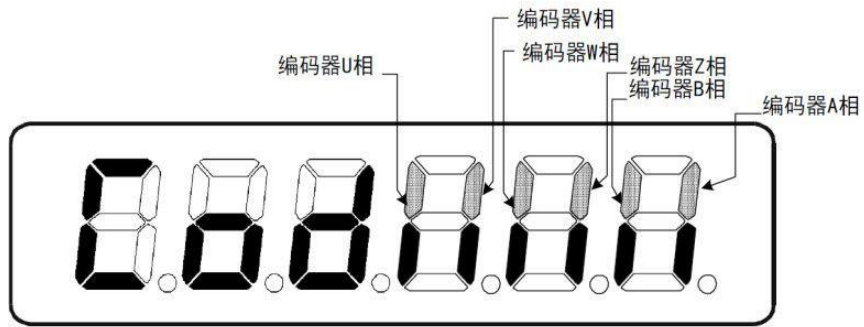

Figure 5.4 Status Display of Encoder Feedback Signal

(When strokes lighten and there is signal input, the encoder is ON; when it goes out, the encoder is disconnected to OFF.)

编码器 U 相

Encoder's U-phase 编

码器 V 相 Encoder's

V-phase 编码器 W

相 Encoder's W-

phase 编码器 Z 相

Encoder's Z-phase 编

码器 B 相 Encoder's

B-phase 编码器 A 相

Encoder's A-phase

Parameter Modification Mode (PA--)

Press **Enter** to enter the parameter modification mode — PA-- || . Press **↑** and **↓** to increase or decrease a parameter number. Press **Enter** to enter and modify a parameter. The decimal points at the lower right corner of the digital tube will lighten when a parameter is being modified; and they will go out when **Enter** is pressed again. Press **←** to return.

PA--0	Parameter password	→	385	User password
PA--1	Motor type code	→	51	Stands for 15015 type motor
PA--4	Control mode selection	→	0	Position control mode

Table 5.3 Operation of Parameter Modification Mode

Parameter Management Mode (EE--)

Press **Enter** to enter the parameter management mode — EE-- || . Press **↑** and **↓** to increase or decrease a parameter. Finding a menu that should be stored or restored and pressing **Enter** for more than 3 seconds will make — **Finish** || display, which means that the operation is successful and will be effective after power cut off. — **Error--** || will appear in case of failure or incorrect password.

EE--SET	Store parameter	→	Enter	Press down for more than 3 seconds
EE--RD	Read parameter	→	Enter	Press down for more than 3 seconds
EE--BA	Backup parameter	→	Enter	Press down for more than 3 seconds
EE--RS	Restore backup	→	Enter	Press down for more than 3 seconds
EE--DEL	Restore default	→	Enter	Press down for more than 3 seconds

Table 5.4 Operation of Parameter Management Mode

1. **EE—SET write in parameter.** The password for Parameter PA—0 should be 315. EE—SET is mainly used to store a parameter permanently.
2. **EE—BD backup parameter** means writing parameters with better effect in current servo state in the EEPROM backup area and EE—RS is used in combination of EE—BD.
3. **EE—BD restore backup** means restoring the backup parameters in the backup area from EEPROM into a parameter table.
4. **EE—BD restore default** is used to restore a default in case of parameter confusion or unclear reasons, etc. when the new adaptive motor is debugged.

When restoring a default, find the corresponding motor model, set the password for PA—0 to 385 and PA--1 to the type code corresponding to the motor, and then restore the default.

JOG Operational Mode (Jr--)

Press **Enter** to enter the jog operation mode — Jr-- || . Press **Enter** to enter jog operation mode — J-- || . The jog speed is set via Parameter PA21.

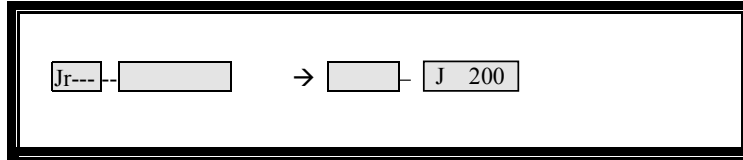

Table 5.5 Operation of JOG Operational Mode

Speed Trial Run Mode (Sr- -)

Press **Enter** to enter the speed trial run mode —Sr-- || . Press **Enter** to enter the jog operational mode —S-- || , speed command and motor direction. Press **↑** and **↓** to change the magnitude and plus/minus of a value.

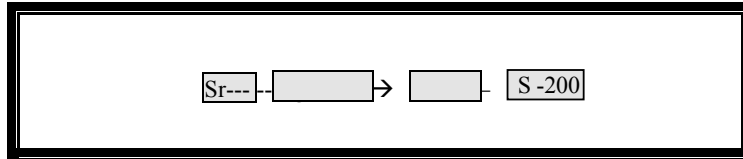

Table 5.6 Operation of Speed Trial Run Mode

Automatic Zeroing Mode of Analog Value (AU- -)

I. Zeroing of Speed Analog Value

Press **Enter** to enter the analog value zeroing mode —AU--spd || and press **Enter** again for more than 3 seconds to enter the zeroing mode of speed analog value —Start || . After that, —Finish || will be displayed and the zero drift value will be automatically stored to PA45 (or PA39). Thereafter the zero drift value stored in PA45 (or PA39) can be also modified manually and then stored manually.

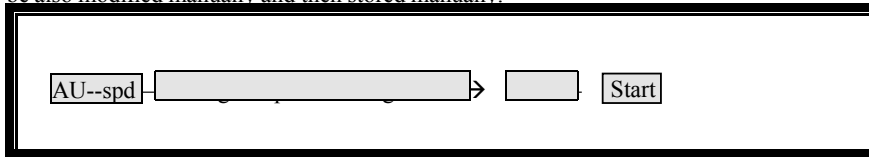

Table 5.7a Operation of Zeroing Mode of Speed Analog Value

- Parameter PA49 can be used to set the threshold voltage (unit: rpm).

II. Zeroing of Torque Analog Value

Press **Enter** to enter the analog value zeroing mode —AU--trq || and press **Enter** again for more than 3 seconds to enter the zeroing status of speed analog value —Start || . After that, —Finish || will be displayed and the zero drift value will be automatically stored to PA45 (or PA39). Thereafter the zero drift value stored in PA45 (or PA39) can be also modified manually and then stored manually.

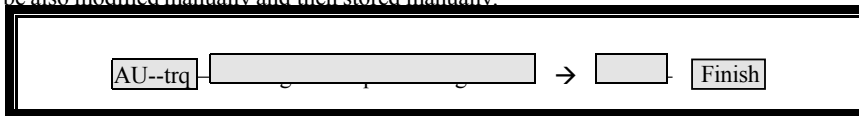

Table 5.7b Operation of Zeroing Mode of Torque Analog Value

Automatic Zeroing Mode of Encoder (CO- -)

I. Automatic Zeroing of Encoder

Press **Enter** to enter the zeroing mode of the encoder —CO-- || . Press **Enter** again for more than 3 seconds and the automatic zeroing of the encoder will start, and —Finish || will be display when the automatic zeroing is

finished.

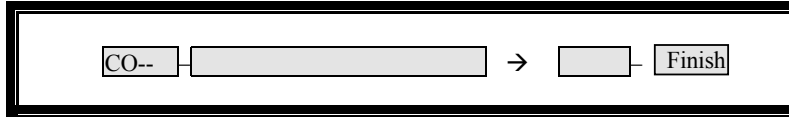

Table 5.8 Operation of Automatic Zeroing Mode of Encoder

- The automatic zeroing of the encoder is mainly used to check the angle of Z pulse after the encoder for the servo driver is installed.

Open Loop Operation Mode

I. Open Loop Operation

Press **Enter** to enter the open loop operation mode — **OL--** || . Press **Enter** again for more than 3 seconds and the open loop operation mode starts up and the motor rotates. After that — **Finish** || will be display.

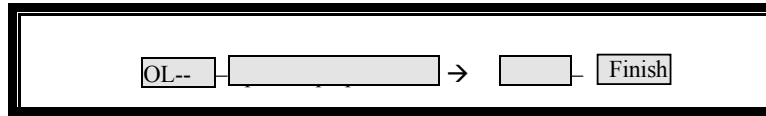

Table 5.9 Operation of Open Loop Operation Mode

- The open loop operation is used to preliminarily determine whether the servo driver has obvious quality problems such as abnormal assembly of the bearing and the rotor, etc.

Chapter VI Parameters

List of Parameters [PA Mode]

Parameter No.	Parameter Name	Unit	Range of Parameter	Default
0	Parameter password	*	0-9999	315
1	Motor model	*	0-52	50
2	Software version No.	*	*	98
3	Initial status display	*	0-21	0
4	Control mode selection	*	0-6	0
5	Speed proportional gain	Hz	50-500	150
6	Speed integral time constant	mS	1-1000	20
7	Torque filter	%	20-500	100
8	Speed detection filter	%	20-500	100
9	Position proportional gain	1/S	1-500	40
10	Position feed-forward gain	%	0-100	0
11	Cut-off frequency of position feed-forward filter	Hz	1~1200	300
12	Count down numerator of position command	*	1-32767	1
13	Count down denominator of position command	*	1-32767	1
14	Input mode for position command pulse	*	0-2	0
15	Reversion of the direction of position command pulse	*	0-1	0
16	Positioning completion range	Pulse	0-30000	20
17	Position overproof detection range	x100 pulse	0-30000	400
18	Position overproof incorrect and ineffective	*	0-1	0
19	Smoothing filter for position command	0.1mS	0-30000	0
20	Disabled input of Driver ineffective	*	0~1	1
21	JOG operation speed	r/min	-3000-3000	120
22	Selection of internal and external speeds	*	0-2	1
23	Maximum speed limit	r/min	0-4000	3600
24	Internal speed 1	r/min	-3000-3000	0
25	Internal speed 2(motor zeroing current)	r/min	-3000-3000	100
26	Internal speed 3	r/min	-3000-3000	300
27	Internal speed 4	r/min	-3000-3000	-100
28	Arrival speed	r/min	0-3000	500
29	Torque command input gain of analog value	0.1V/100%	10-100	50
30	User torque overload alarm value	%	50-300	200
31	User torque overload Alarm detection time	mS	10-30000	0
32	Control mode switching permissible	*	0-1	0
33	Reversion of torque input direction of analog value	*	0-1	0
34	Internal CCW torque limit	%	0-300	300*
35	Internal CW torque limit	%	-300-0	-300*

36	Command pulse signal filter factor	*	0-3	1
37	Command direction signal filter factor	*	0-3	0
38	External CCW and CW torque limit	%	0-300	100
39	Zero drift compensation for analog value torque command	*	-2000-2000	0
40	Acceleration time constant	mS	1-10000	100
41	Deceleration time constant	mS	1-10000	100
42	Alarm 15 shielded	*	0-1	1
43	Analog speed command gain	(r/min) / V	10-3000	300
44	Reversion of Analog speed command direction	*	0-1	0
45	Zero drift compensation for Analog speed command	*	-5000-5000	0
46	Analog speed command filter	Hz	0-1000	300
47	Setting of the delayed conduction of the band-type brake when the motor is enabled.	×10mS	0-200	80
48	Setting of enable time delay when the band-type brake of the motor is closed.	×10mS	0-200	0
49	Analog value voltage threshold value speed control	r/min	0-3000	0
50	Speed limited during torque control	r/min	0-5000	3600*
51	Dynamic electronic gear effective	*	0-1	0
52	Count down numerator of the command on the second position	*	1-32767	1
53	Lower 4 digit input terminal forced ON input	Binary system	0000-1111	0000
54	Higher 4 digit input terminal forced ON input	Binary system	0000-1111	0000
55	Lower 4 digit input terminal reversion setting	Binary system	0000-1111	0000
56	Higher 4 digit input terminal reversion setting	Binary system	0000-1111	0000
57	Control word for output terminal reversion	Binary system	0000-1111	0000
58	Time setting of Demonstration Mode 2	0.1S	1-30000	600

Detailed Explanation of Parameters

Parameter No.	Parameter Name	Detailed Explanation of Functions	Range of parameter [Default]
0	Parameter password	<p>a. The user password is 315.</p> <p>b. The password for type code is 385 and only used for modifying Parameter PA1.</p> <p>c. The password for the motor manufacturer is 510 and parameters are effective online (not recommended).</p>	<p>0-9999</p> <p>[315]</p>
1	Type code	<p>a. The type code is used to match different models of servo motors. Set the servo according to Table 2.2 and then restore the factory value, which will be effective only after power down.</p> <p>b. Modify this parameter. Parameter PA0 should be 385.</p>	<p>0-9999</p> <p>[38]</p>
2	Software version No.	<p>a. Only software version No. is displayed and read only.</p> <p>b. Where the version No. is an odd number, the servo driver is all-function type one; where the version No. is even number, the servo driver is a pulse type one.</p> <p>c. The all-function type has a function of analog value control, but the pulse type hasn't.</p>	<p>80-9999</p> <p>[98]</p>
3	Initial status display	<p>The initial display status of the digital tube when the driver is switched on</p> <p>0: Display motor speed</p> <p>1: Display the lower 5 digit at the current position</p> <p>2: Display the higher 5 digit at the current position</p> <p>3: Display the lower 5 digit of position command (command pulse accumulation);</p> <p>4: Display the higher 5 digit of position command (command pulse accumulation);</p> <p>5: Display the lower 5 digit of position deviation;</p> <p>6: Display the higher 5 digit of position deviation;</p> <p>7: Display motor torque;</p> <p>8: Display motor current;</p> <p>9: Display Z pulse count;</p> <p>10: Display control mode;</p> <p>11: Display position command pulse frequency;</p> <p>12: Display speed command;</p> <p>13: Display torque command;</p> <p>14: Display the absolute position of the rotor in one revolution;</p> <p>15: Display input terminal status;</p> <p>16: Display output terminal status;</p> <p>17: Display encoder input signal;</p> <p>18: Display operation status;</p> <p>19: Display alarm code;</p>	<p>0-19</p> <p>[0]</p>
4	Control mode selection	<p>0: Position control mode ;</p> <p>1: Speed control mode:</p> <p>a. The internal and external speeds are selected via Parameter PA22;</p>	<p>0-6</p> <p>[0]</p>

		<p>b. Four types of internal speeds are selected via the combination of Pin 14 SC1 and Pin 15 SC2 in the CN1 interface.</p> <p>SC1 OFF, SC2 OFF: internal speed 1. The rotational speed is set via PA24.</p> <p>SC1 ON, SC2 OFF: internal speed 2. The rotational speed is set via PA25.</p> <p>SC1 OFF, SC2 ON: internal speed 3. The rotational speed is set via PA26.</p> <p>SC1 ON, SC2 ON: internal speed 4. The rotational speed is set via PA27.</p> <p>2: Control mode for trial run;</p> <p>3: JOG control mode;</p> <p>The rotational speed is set via Parameter PA21.</p> <p>4: Encoder zeroing mode</p> <p>Used to adjust the zero point of the coding mask before the delivery of the motor.</p> <p>5: Open loop operation mode:</p> <p>Used to detect the motor and the encoder.</p> <p>6: Torque control mode</p>	
5	Speed proportional gain	<p>a. Increase the proportional gain of rigid set speed loop regulator.</p> <p>b. The greater the set value is, the higher the gain is and the greater the rigidity is. The value of the parameter is determined according to the specific model of the servo driver system and load condition. Generally, the greater the load inertia is, the greater the set value is.</p> <p>c. Set a greater value as much as possible without oscillation produced by the system.</p>	<p>50-500</p> <p>[150]</p>
6	Speed integral time constant	<p>a. Set the time constant for the integral of the speed loop regulator.</p> <p>b. Able to inhibit motor overshooting. The smaller the set value is, the faster the integral speed is. A too small set value easily produces overshooting, while a too great set value slows the response.</p> <p>c. The set value is determined according to the specific model of the servo driver system and load condition. Generally, the greater the load inertia is, the greater the set value is.</p>	<p>1-1000</p> <p>[20]</p>
7	Torque filter	<p>a. Used to remove noises and set the characteristic of the torque command filter.</p> <p>b. Used to inhibit the resonance to be produced by the torque.</p> <p>c. The greater the value is, the greater the cut-off frequency is and the smaller the vibration and noise produced by the motor is. Where the load inertia is very great, the set value can be increased appropriately. A too great value can slow the response and could lead to oscillation.</p> <p>d. The smaller the value is, the smaller the cut-off frequency is and the faster the response is. Where a greater torque is needed, the set value can be decreased appropriately.</p>	<p>20-500</p> <p>[100]</p>
8	Speed detection filter	<p>a. Used to remove noises and set the characteristic of the speed detection filter.</p> <p>b. The greater the value is, the greater the cut-off frequency is and the noise produced by the motor is. Where the load inertia is very great, the set value can be changed appropriately. A too great value can slow the response and could lead to oscillation. The smaller the value is, the greater the cut-off</p>	<p>20-500</p> <p>[100]</p>

		frequency is and the faster the speed feedback response is. Where a faster speed response is needed, the set value can be decreased appropriately.	
9	Position proportional gain	<p>a. Used to set the proportional gain of the position loop regulator.</p> <p>b. The greater the set value is, the greater the gain is, the greater the rigidity is, and the smaller the hysteric value of position under the same condition of frequency command pulse. However, A too great set value may lead to oscillation or overshooting.</p> <p>c. The value of the parameter is determined according to the specific model of the servo driver system and load condition.</p>	<p>1-500</p> <p>[40]</p>
10	Position feed-forward gain	<p>a. Used to set the feed-forward gain of the position loop.</p> <p>b. When the feed-forward gain is set to 100%, it means that the hysteric value of position is always zero under the command pulse of any frequency.</p> <p>c. Increase of feed-forward gain of the position loop is able to improve the high speed response characteristic of the control system, but it makes the position loop of the control system unstable and easily produce oscillation.</p> <p>d. The feed-forward of the position loop generally is zero unless a very high response characteristic is needed.</p>	<p>0-100</p> <p>[0]</p>
11	Cut-off frequency of position feed-forward filter	<p>a. Used to set the cut-off frequency of the low-pass filter of the position loop feed-forward value.</p> <p>b. The function of this filter is to increase the stability of composite position control.</p>	<p>1-1200</p> <p>[300]</p>
12	Count down numerator of position command	<p>a. Where the program of the system makes lead screw move 5 mm (5000 pulses), the motor needs to rotate one revolution.</p> <p>PA12/PA13=Pulse numerator/Pulse denominator= Actual feedback/Command pulse</p>	<p>1-32767</p> <p>[1]</p>
13	Count down denominator of position command	<p>=The number of wires for the motor encoder (2500 wires) x the number of frequency doublings (4)</p> <p>=10000/5000=2/1</p> $\frac{PA12}{PA13} = \frac{\text{脉冲分子}}{\text{脉冲分母}} = \frac{\text{实际反馈}}{\text{指令脉冲}}$ $= \frac{\text{电机编码器线数}(2500 \text{ 线}) \times \text{倍频数}(4)}{\text{指令脉冲数}(5000)}$ $= \frac{10000}{5000} = \frac{2}{1}$ <p>b. 若电机与丝杆直联,丝杆螺距为 6 毫米:</p> $\frac{PA12}{PA13} = \frac{10}{\text{丝杆螺距}(6)} = \frac{5}{3}$ <p>注: 数控机床可参照 b 来设置更为直观。</p> <p>齿轮比范围 : $1/100 \leq G \leq 100$</p> <p>b. Where the motor is connected directly to the lead screw with a pitch of 6mm:</p> <p>PA12/PA13=10/lead screw pitch(6)=5/3</p> <p>Note: a NC machine can be set more visually by referring to b.</p> <p>Range of gear ratio: $1/100 \leq G \leq 100$</p>	<p>1-32767</p> <p>[1]</p>
14	Input mode for position	<p>Three types of pulse input modes can be set:</p> <p>0: pulse + sign</p>	<p>0-2</p> <p>[0]</p>

	command pulse	1: CCW pulse/CW pulse; 2: Two-phase orthogonal pulse input. See Figure 4.4-c Pulse Mode on Page 28.	
15	Reversion of the direction of position command pulse	0: Default direction. 1: Direction reversion.	0-1 [0]
16	Positioning completion range	a. When the value in the position deviation counter is less than or equal to the set value during position control, positioning completion is COIN ON; otherwise it is OFF. b. The positioning completion range is a speed arrival signal in other control modes.	0-3000 [20]
17	Position overproof detection range	When the count value of the position deviation counter is more than the set value of this parameter under the mode of position control, the servo driver alarms.	0-3000 [400]
18	Position overproof incorrect and ineffective	0: Detection is effective. 1: The shielding position is overproof, Parameter 4 alarms and Parameter PA17 is ineffective.	0-1 [0]
19	Smoothing filter for position command	Mainly for PC no acceleration and deceleration, not with exponential form of acceleration and deceleration. This parameter can be used for smooth filtering of command pulse and optimize acceleration and deceleration. This filter loses no pulses, but the execution speed is possible to be delayed.	0-3000 [0]
20	Disabled input of Driver ineffective	0: The disable inputs of CCW and CW are effective. 1: The disable inputs of CCW and CW are ineffective.	0-1 [1]
21	JOG operation speed	The setting of forward and reverse speeds when the JOG mode is set	-3000-3000 [120]
22	Selection of internal and external speeds	0: This parameter is got from an internal speed. 1: This parameter is got from an external analog value (-10V-+10V). 2: This parameter is got from an external analog value (0-+10V; Pins 14 and 15 are used to control forward and reverse directions.	0-2 [1]
23	Maximum speed limit	The setting of the maximum speed limit of the servo motor is related to the servo motor. The maximum speed of the motor should be set according to the adaptive model of PA1.	0-5000 [3600]
24	Internal speed 1/zeroing current	When PA4=1 and P22 =0: When Pin CNISC1 is OFF and Pin SC2 is OFF, this parameter is internal speed 1.	-3000-3000 [0]
25	Internal speed 2	a. When PA4=1 and PA22=0 When Pin CNISC1 is ON and Pin SC2 is OFF, this parameter is internal speed 2. b. When PA4 is equal to 4, set the percentage of the motor zeroing current.	-3000-3000 [100]
26	Internal speed	When PA4=1 and PA22=0:	-3000-3000

	3	When Pin CNISC1 is OFF and Pin SC2 is ON, this parameter is internal speed 3.	[300]
27	Internal speed 4	When PA4=1 and PA22=0 : When Pin CNISC1 is ON and Pin SC2 is ON, this parameter is internal speed 4.	-3000-3000 [-100]
28	Arrival speed	In non-position mode: When the motor speed is more than this set value, COIN is O; otherwise COIN is OFF. This parameter is only used for determination of the motor speed and has no directivity.	0-3000 [500]
29	Torque command input gain of analog value	a. Used to set the proportional relation between the input voltage of analog value torque and the actual operation torque of the motor; b. The unit of the set value is 0.1V/100%; c. The default value is 50, which corresponds to 5V/100%, namely inputting 5V voltage will produce 100% rated torque.	10-100 [50]
30	User torque overload alarm value	① Used to set the overload value of the user torque. This value is the percentage of the rated torque. The limited values of the torque have no directivity and both forward and reverse limited values are protected. ② When PA31>0, motor torque >PA30 and the duration >PA31, the driver alarms with an Alarm No. Err-29 and stops rotating. After the alarm, the driver must be electrified again to clear the alarm.	0-300 [200]
31	User torque overload Alarm detection time	The unit of the user torque overload detection time is millisecond; When this time is zero, the alarm function of the user torque overload is ineffective.	0-30000 [0]
32	Control mode switching permissible	0: Pin 11(A-CLA) of CN1 is only effective for alarm clearance. 1: When Parameter PA=0, Pin 11 (A-CLA) of CN1 is only effective for switching of position and speed (default position effective). When Parameter PA 4=1, Pin 11 (A-CLA) of CN1 is only effective for switching of speed and torque (default position effective). When Parameter PA 4=6, Pin 11 (A-CLA) of CN1 is only effective for switching of torque and position (default position effective).	0-1 [0]
33	Reversion of torque input direction of analog value	Used for reversion of the torque input polarity of analog value. 0: When the torque command of the analog value is positive, the torque direction is CCW; 1: When the speed command of the analog value is positive, the torque direction is CW;	0-1 [0]
34	Internal CCW torque limit	Used to set the percentage of the internal torque limit of the motor CCW direction. Example: If this parameter is set to two times of the rated torque, the set value is 200; This set value is limited and effective all the time.	0-300 [250]
35	Internal CW torque limit	Used to set the percentage of the internal torque limit of the motor CW direction.	0- -300 [-250]

		<p>Example: If this parameter is set to two times of the rated torque, the set value is 200;</p> <p>This set value is limited and effective all the time.</p>	
36	Command pulse signal filter factor	<p>When PA4=0, this parameter is effective during position control.</p> <p>The greater the set value is, the strong the anti-interference to the command pulse is; at the same time, the smaller received pulse frequency could make the pulse unable to be received.</p> <p>Make adjustment to the advance and lag of the time sequence of the pulse and the direction signal.</p>	<p>0-3</p> <p>[1]</p>
37	Command direction signal filter factor	<p>When PA4=0, this parameter is effective during position control.</p> <p>Make adjustment to the advance and lag of the time sequence of the pulse and the direction signal.</p>	<p>0-3</p> <p>[0]</p>
38	External torque limit	<p>When PA4=6, Pin 14 or Pin 15 of CN1 is connected with 0V:</p> <p>CCW, CW torque percentage limit, positive and negative effect at the same time .</p> <p>PA38 is less than the set values PA34 and PA35.</p>	<p>0-300</p> <p>[100]</p>
39	Zero drift compensation for analog value torque command	<p>The zero drift compensation value to the analog value torque input is namely positive and negative offsets.</p>	<p>-2000-2000</p> <p>[0]</p>
40	Acceleration time constant	<p>The set value means the acceleration time of the motor from 0-1000r/min.</p> <p>Linear acceleration and deceleration characteristics are only used for the speed control mode.</p> <p>If the upper computer has acceleration and deceleration characteristics, this parameter should be set to zero.</p>	<p>1-10000</p> <p>[100]</p>
41	Deceleration time constant	<p>The set value means the deceleration time of the motor from 1000-0r/min.</p> <p>Linear acceleration and deceleration characteristics are only used for the speed control mode.</p> <p>If the upper computer has acceleration and deceleration characteristics, this parameter should be set to zero.</p>	<p>1-10000</p> <p>[100]</p>
42	Alarm 15 shielded	<p>0: Alarm 15 takes effect. 1: Alarm 15 is shielded.</p> <p>Enhance the anti-interference of the UVW signal of the motor encoder.</p>	<p>0-1</p> <p>[1]</p>
43	Analog value speed command gain	<p>Used to set the proportional relation between the speed input voltage of analog value and the actual operation speed of the motor.</p> <p>Example: $\pm 10V$ voltage corresponds to positive and negative 3000revolutions and can be set to $3000/10 = 300$ r/min/v; namely 1V corresponds to 300 revolutions.</p>	<p>10-3000</p> <p>[300]</p>
44	Reversion of Analog value speed command direction	<p>Used for reversion of the speed input of Analog value.</p> <p>0: When the speed command of the analog value is positive, the speed direction is CCW;</p> <p>1: When the speed command of the analog value is positive, the speed direction is CW;</p>	<p>0-1</p> <p>[0]</p>

45	Zero drift compensation for Analog value speed command	The zero drift compensation value to the analog speed torque input is namely positive and negative offsets. This parameter is automatically modified and stored during the automatic zeroing of the analog value. See Table 5.7a on Page 41.	-5000-5000 [0]
46	Analog speed command filter	This filter is a low-pass filter to the speed input of the analog value. The greater the set value, the faster the response speed to the analog value of the speed input is and the greater noise is; the smaller the set value, the slower the response speed to the analog value of the speed input is and the smaller noise is;	0-1000 [300]
47	Setting of the delayed conduction of the band-type brake when the motor is enabled.	When the maximum value of this parameter is 500, the band-type brake is delayed for 5 seconds (default 0.8 s). This parameter means the time from enabling the motor to BRK+ and BRK- delayed conduction of the band-type brake when the diver is normally electrified. The band-type brake is not conducted during alarm.	0-500 [80]
48	Setting of the enable time delay when the band-type brake of the motor is closed.	When the maximum value of this parameter is 500, the band-type brake is delayed for 5 seconds (default 0.8 s). This parameter means the time from disconnection of BRK+ and BRK- to enabling delay when the diver is normally electrified. The band-type brake is not time delayed during alarm.	0-500 [0]
49	Analog value voltage threshold value speed control	Used to set the threshold values of positive and negative going voltages of the analog value during speed control.	[0]
50	Speed limit during torque control	This parameter is the maximum speed limit during torque control. Note: Idle load easily leads to overspeed.	1-5000 [2500]
51	Dynamic electronic gear	0: CN1 interface and the function (command pulse disabled) of input terminal INH are effective. 1: CN1 interface and the function (dynamic electronic gear) of input terminal INH are effective. When INH terminal is OFF, the input electronic gear PA12/PA13; when INH terminal is ON, the input electronic gear is PA52/PA13.	0-1 [0]
52	Count down numerator of the command on the second position	When INH terminal is OFF, the input electronic gear is No.12/No.13; when INH terminal is ON, the input electronic gear is No.54/No.13.	0-32767 [1]
53	Lower 4 digit input terminal forced ON input	ONs and OFFs of the following functions are performed using the changes of Parameters 0 and 1 but without using an external circuit. SON: 伺服使能; [0001] A-CLR: 报警清除; [0010] FSTP: CCW 驱动禁止; [0100]	0000-1111 [0000]

		RSTP: CW 驱动禁止; [1000] SON: Servo enable: [0001] A-CLR: Alarm clearance [0010] FSTP: CCW driver disabled [0100] RSTP: CW driver disabled [1000]	
54	Higher 4 digit terminal forced ON input	CLE/SC1/ZEROSPD: Deviation counter reset/speed selection 1/zero speed clamping: [0001] INH/SC2: command pulse disabled/speed selection 2 [0010] FIL: CCW torque limit [0100] RIL: CW torque limit [1000]	0000-1111 [0000]
55	Lower 4 digit input terminal logic reversion	To realize the reversion of the functions using the changes of Parameters 0 and 1 (namely the reversion of the original external switch circuit input; normal open changes to normal close and normal close changes to normal open). SON: servo enable [0001] A-CLR: Alarm clearance [0010] FSTP: CCW driver disabled [0100] RSTP: CW driver disabled [1000]	0000-1111 [0000]
56	Higher 4 digit input terminal logic reversion	To realize the reversion of the functions using the changes of Parameters 0 and 1 (namely the reversion of the original external switch input circuit; normal open changes to normal close and normal close changes to normal open). CLE/SC1/ZEROSPD: deviation counter reset Speed selection 1/zero speed clamping; [0001] INH/SC2: command pulse disabled/speed selection 2; [0010] FIL: CCW torque limit [0100] RIL: CW torque limit [1000]	0000-1111 [0000]
57	Output terminal logic reversion	To realize the reversion of the functions using the changes of Parameters 0 and 1 (namely the reversion of the original external switch input circuit; normal open changes to normal close and normal close changes to normal open). SRDY: servo ready; [0001] ALM: servo alarm; [0010] COIN: positioning completed/speed reached; [0100] BRK: motor band-type brake; [1000]	0000-1111 [0010]
58	Time setting of Demonstration Mode 2	Used to set the high-speed ageing time of the servo motor (unit: 0.1minute) in demonstration mode 2.	1-30000 [600]

Remarks

It is hereby declared that:

- PA-59 can reach PA-299 at most in default in the parameter structure of MG -1000 series of servo drivers. The internal super password of the manufacturer or the password of the cooperation manufacturer of the servo motor should be input.

Chapter VII Failures and Diagnosis

List of Alarms

(Table 7.1)

Alarm No.	Alarm Name	Failure Diagnosis
1	Overspeed	The speed of the servo motor exceeds the set value.
2	Main circuit overvoltage	The voltage of three-phase or two-phase power supply is too high or the brake fails to work.
3	Main circuit undervoltage	The voltage of three-phase or two-phase power supply is too low.
4	Positive overproof	The value of the position deviation counter exceeds the set value and or the voltage is too low.
5	Motor overheat	The temperature of the motor is too high.
6	Motor stalling	The motor is jammed and unable to rotate freely, or the load is too great.
7	Driver disablement abnormal	CCW and CW has no input or Parameter Pa20 is not 1.
8	Position deviation counter overflow	The absolute value of the value of the position deviation counter exceeds 230.
9	Encoder failure	The signal of the encoder is incorrect.
10	Software failure	The chip of the circuit board fails.
11	IPM module failure	IPM intelligent module fails.
12	Overcurrent	The current of the motor is too great.
13	Overload	The driver and the motor overloads (instantaneous overcurrent) and are unable to rotate freely.
14	Brake failure	The braking resistor or circuit fails.
15	Encoder count incorrect	Encoder count abnormal.
16	Motor thermal overload	The electric thermal value of the motor exceeds the set value.
17	Speed response failure	Speed error is too great for a long time.
19	Hot reset	The system is hotly reset.
20	EEPROM failure	EEPROM incorrect.
23	Housing electric leakage failure	External short circuit or the motor leakage
29	User torque overload alarm	The load of the motor exceeds the value and duration set by the user.
30	Encoder Z-pulse loss	Encoder Z-pulse incorrect.
31	Encoder UVW signal broken	Encoder UVW signal is incorrect or not matched to the encoder.
32	Encoder UVW signal interference	All-high electrical level or all-low electrical level exists in UVW signal.

Troubleshooting

(Table 7.2)

Alarm No.	Alarm Name	Operation Status	Cause	Solution
1	Overspeed	Power on	●Driver or motor failure	★Replace the driver.
			●Check parameters	★Check whether internal enable
		Being enabled	●Short circuit between motor and UVW	★ Check the wire of the motor.
			●Encoder Position 0 deviation	★Motor encoder zeroing
			● The parameters of the servo incorrect	★ Restore the parameters
		During the operation of the motor	● Motor connector short circuited	★Check that there is no water in the motor connector.
			●Command speed of too fast	★Reduce the command speed.
●Acceleration/deceleration unstable	★Adjust the acceleration/deceleration constant.			
		●Load too great	★Reduce the load.	
2	Main circuit overvoltage	Power on	● Power supply voltage too high	★Reduce the voltage.
			● Power supply waveform abnormal	★Replace the power supply.
			● Servo driver failure	★Replace the servo driver.
		In operation	●Circuit board failure	★ Replace the servo driver.
			● Braking circuit failure	★Check the braking resistor.
3	Main circuit undervoltage	Being enabled	● Main power supply voltage too low	★ Replace the power supply.
			●Circuit board failure	★Replace the servo driver.
			●Soft start circuit failure	★Replace the servo driver.
		In operation	● transformer capacity insufficient	★Increase the transformer capacity.
			●Power supply wire loose	★ Tighten wiring terminals
			●Circuit board failure	★Replace the servo driver.
4	Position overproof	In operation	● Command speed too faster	★Reduce the command speed.
			● Input voltage too low	★ Check R/S/T power supply.
			● Parameter PA17 too small.	★Increase the parameter appropriately.
			●Wire loose	★ Check and tighten the wire.
5	Motor overheat	Power on	● Motor damaged	★ Replace the motor.
			● Sensor wire broken	★Check the wire and replace the sensor.
		In operation	●Motor power too small	★ Replace the current motor by a high-power motor.
			● Motor interface short circuited	★Take waterproof and dustproof measures.
			● Servo parameters incorrect	★Match a right motor model.
6	Motor stalling	In operation	●transmission partially jammed	★ Disconnect the mechanical part.
			●Load too great	★ Reduce the load
			●Motor failure	★Replace the motor.

7	Disable abnormal	Power on	<ul style="list-style-type: none"> • Check parameters and wires 	★PA20, CW and CWW wires
8	Position deviation counter overflow	In operation	<ul style="list-style-type: none"> • Motor stalling 	★Check the load.
			<ul style="list-style-type: none"> • Command frequency abnormal 	★ Reduce the speed of the upper computer.
			<ul style="list-style-type: none"> •Wiring incorrect 	★Check the wire and connect the shielding layer.
9	Encoder failure	Power on	<ul style="list-style-type: none"> •Encoder wiring incorrect 	★ Connect the wire correctly.
			<ul style="list-style-type: none"> •Encoder damaged 	★ The encoder is a fragile article and should be replaced.
			<ul style="list-style-type: none"> • Encoder 5V voltage low 	★Shorten the wire or replace the driver.
		In operation	<ul style="list-style-type: none"> • CN2 connector contact poor 	★Tighten the CN2 connector.
			<ul style="list-style-type: none"> •Hidden trouble exists in cable faulty welding. 	★Replace the cable.
10	Software failure	Power on	<ul style="list-style-type: none"> •software download mismatching 	★Update the software.
			<ul style="list-style-type: none"> •The chip of the circuit board failure 	★Find out the interference and replace the driver.
11	IPM module failure	Power on	<ul style="list-style-type: none"> •Circuit board failure 	★Replace the servo driver.
			<ul style="list-style-type: none"> • Short circuit between U, V and W of the motor 	★ Check the wire and replace the motor.
		In operation	<ul style="list-style-type: none"> • Motor failure 	★Check the wire and replace the motor.
			<ul style="list-style-type: none"> • Poor connection to power supply 	★ Check the wire and prevent interference.
12	Overcurrent	Power on or in operation	<ul style="list-style-type: none"> • Motor damaged 	★Replace the motor.
			<ul style="list-style-type: none"> •Short circuit between U, V and W 	★Check the wire and replace the servo driver.
			<ul style="list-style-type: none"> •Overload 	★Replace the current motor by a high-power motor.
13	Overload	Power on	<ul style="list-style-type: none"> • The motor is damaged and water has entered the motor. 	★Replace the motor.
			<ul style="list-style-type: none"> •Circuit board failure 	★Replace the servo driver.
		In operation	<ul style="list-style-type: none"> • Mechanical load too great 	★Reduce the load.
			<ul style="list-style-type: none"> •Mechanical transmission not freely 	★Check Mechanical transmission parts.
			<ul style="list-style-type: none"> •Short circuit between U, V and W 	★Check the cable.
<ul style="list-style-type: none"> •The band-type brake fails to loosen. 	★Ensure that power supply for the band-type brake is stable.			
14	Brake failure	Power on	<ul style="list-style-type: none"> •Circuit board failure 	★Replace the servo.
		In operation	<ul style="list-style-type: none"> •Braking resistor damaged 	★Check the wire of the braking resistor.
			<ul style="list-style-type: none"> •Braking capacity insufficient 	★ Prolong the

				acceleration/deceleration time.
			●Mechanical inertia too great	★Reduce the mechanical inertia.
15	Encoder count incorrect	In operation	● Encoder damaged	★Replace the encoder.
			●Encoder wiring incorrect	★Check the wiring and replace the encoder.
			● Encoder power supply unstable	★5V voltage should be stable.
			●The number of encoder wires incorrect	★Adjust the number of wires corresponding to the parameter.
16	Motor thermal overload	Power on	● Servo parameter incorrect	★ Restore the factory value.
		In operation	●Mechanical transmission not freely	★Add lubricant and reduce load.
			●Overload time long	★Reduce load; start/stop are smooth.
17	Speed response failure	In operation	● Long-time error too great	★Adjust parameter position feed-forward.
			●Start/start time too short	★Adjust the acceleration/deceleration time.
19	Hot reset	In operation	● Power supply unstable	★ Check power supply and wiring.
20	ROM alarm	In operation	● Parameter storage alarm	★Restore the parameter and replace the servo.
23	Electric leakage failure	In operation	●Short circuit or motor leakage	★Check the wiring or replace the motor.
29	Torque insufficient	In operation	● Set torque exceeded	★Check Parameters PA30 and PA31.
			● Check the model selection of the motor.	★Readapt the motor again.
			● Mechanical overload	★ Disconnect the load and try again.
30	Encoder Z-pulse loss	In operation	●Z-pulse doesn't exit.	★Replace the encoder.
			●Cable weld line incorrect	★Check the weld line.
			●5V Voltage unstable	★Shorten the wire and reduce attenuation.
			●Poor shielding leads to interference.	★Well ground the shielding layer.
31	Encoder UVW signal incorrect	In operation	●UVW pulse doesn't exit.	★Replace the encoder.
			●Cable weld line incorrect	★Check the weld line.
			●5V Voltage unstable	★Shorten the wire and reduce attenuation.
			●Poor shielding leads to interference.	★Well ground the shielding layer.
32	Encoder UVW signal angle misplacement	In operation	●UVW pulse doesn't exit.	★Replace the encoder.
			●Encoder model incorrect	★Check the encoder model.
			●Weld line misplacement	★Check the weld line.
			●5V Voltage unstable	★Shorten the wire and reduce attenuation.
			●Poor shielding leads to interference.	★Well ground the shielding layer.

● Where the Alm red lamp is on and the Alarm —Err--xx || in the digital tube flashes, the alarm is a driver alarm.

Cut off the power in time and find out the cause of the alarm.

Remarks

Chapter VIII Debugging and Application

Notices to Quick Debugging

I. Confirm that wiring is correct.

- R, S, T and U, V, W should not be connected reversely and loosely.
- Check whether the input voltage is three-phase 220V or single-phase 220V.
- Check that Pin 18 in CN1 interface is correctly connected with +24V and that Pins 36 and 9 in CN1 interface are correctly connected with 0V. Poles should not be connected reversely.
- Check that +5V in CN2 interface is correctly connected. Poles should not be connected reversely.
- Check whether the cable for the motor is short circuited or grounded.
- The wiring for the same motor should correspond to the same driver.

II. etermine Energizing Sequence.

- The heavy current and control electricity of **MG1000** series of servos are electrified at the same time.
- If the brake of the band-type brake motor is not controlled by the servo, the brake should not be electrified until the servo is enabled for more than 1 second. Only in this way can the position precision and safety of the equipment be guaranteed.
- Due to integrated design of the heavy current and control of **MG1000** series of servos and adoption of power-down delay discharge, the internal heavy current is immediately cut off after power supply is cut off and the delay discharge of display and control circuits automatically cuts off after several seconds.

For successful use of **MG** -1000 series of drivers, please carefully read the sequence diagram below:

Figure 8.1 Sequence Diagram for Energizing and Alarm

控制回路及主电路电源	断电	1 秒	通电
Control circuit and main circuit power supply	Power down	1s	Power on
伺服报警输出 (ALM)	报警	无报警	
Servo alarm output (ALM)	Alarm	No alarm	
伺服准备好输出 (SRDY)	无准备好	10 毫秒	准备好

Servo ready for output (SRDY)	Not ready	10ms	Ready
伺服使能 (SON)	不使能	10 毫秒	使能
Servo enable (SON)	Failure to enable	1ms	enabled
电机电流	不通电 (自由状态)	1 秒	通电 (电机锁住)
Motor current	Not electrified (free state)	1s	Power on (motor locked)
电机抱闸	无电 (抱闸紧)		有电 (抱闸松)
Motor band-type brake	without power (the brake tight)		with power (the brake loose)

Position Control (Quick adjustment of parameters after power on)

Example: AMG-1000/3A driver matches a 130ST-M15015 motor (position control).

1. Make ensure that the three-phase 220V voltage between R, S and T is correct after power on.
2. Do not connect the servo enable signal temporarily. Check whether there is any alarm and observe the red lamp (**ALM**). If the red lamp is not on, the operation is normally and you can go to the next step.
3. Start the adaptation of parameters.
 - a. Enter the parameter modification mode to change **PA-0** into **—385** || password and then change Parameter **PA-1** into **—51** || corresponding to the motor type code (see Table 2.21 on Page 10).
 - b. Enter the parameter management mode **—EE--** || , transfer to **—DP-def** || and then press down Enter for three seconds. When **—Finish** || appears, it means the default value has been restored according to the current adapted motor and will be effective only after power down.
 - c. After power on again, check several key parameters (See Table 8.1 below) of position control and confirm that they are correct; the upper computer can send out an enable signal (or internal enable) and send out a pulse after the green lamp (**RUN**) is on. Observe the dynamic effect of the motor, appropriately modify the gain and adjust the characteristic of the motor.

PA--4	→	Factory value = 0
PA-12	→	Electronic gear numerator → Factory value=1
	→	
	→	
	→	
PA--6	→	Speed integral time constant → Factory value=2
	→	
PA--8	→	Speed detection filter → Factory value=100
PA--9	→	Position proportional gain → Factory value=40
PA-10	→	

Table 8.1 Adjustment of Key Parameters of Position Control

Speed Control (Quick adjustment of parameters after power on)

Example: A MG1000/3A driver matches a 130ST-M10015 motor (speed control)

1. Confirm that the three-phase 220V voltage between R, S and T is correct after power on.
2. Confirm that the wiring of the differential input of the speed analog value or the single-ended input is

correct.

3. Do not connect the servo enable signal temporarily. Check whether there is any alarm and observe the red lamp (**ALM**). If the red lamp is not on, the operation is normally and you can go to the next step.
4. Start the adaptation of parameters.
 - a. Enter the parameter modification mode to change **PA-0** into **—385** || password and then change Parameter **PA-1** into **—49** || as the motor type code (see Table 2.2 on Page 8).
 - b. Enter the parameter management mode **—EE--** || , transfer to **—DP-def** || and then press down Enter for three seconds. When **—Finish** || appears, it means the default value has been restored according to the current adapted motor and will be effective only after power down.
 - c. After power on again, check several key parameters (See Table 8.2 below) of speed control and confirm that they are correct; the upper computer can send out an enable signal (or internal enable), and send out an analog signal after the green lamp (**Run**) is on and after automatic zeroing. Observe the dynamic effect of the motor, appropriately modify the gain and adjust the zero drift value.

PA--	Control mode	→	Set to 1
PA--20--	Driver disablement ineffective	→	Factory value=1
PA-22	Internal speed command selection	→	Set
PA-40	Acceleration time constant	→	Set as required
PA-41	Deceleration time constant	→	Set as required PA-
Analog	speed command gain	→	Set as required
PA-45	Analog speed zero drift compensation	→	Set as required

Table 8.2 Adjustment of Key Parameters of Speed Control

Torque Control (Quick adjustment of parameters after power on)

Example: AMG1000/3A driver matches a 110ST-M06030 motor (torque control).

1. Confirm that the three-phase 220V voltage between R, S and T is correct after power on.
2. Confirm that the wiring of the differential input of the torque analog value or the single-ended input is correct.
3. Do not connect the servo enable signal temporarily. Check whether there is any alarm and observe the red lamp (**ALM**). If the red lamp is not on, the operation is normally and you can go to the next step.
4. Start the adaptation of parameters.
 - a. Enter the parameter modification mode to change **PA-0** into **—385** || password and then change Parameter **PA-1** into **—38** || corresponding to the motor type code (see Table 2.2 on Page 8).
 - b. Enter the parameter management mode **—EE--** || , transfer to **—DP-def** || and then press down Enter for three seconds. When **—Finish** || appears, it means the default value has been restored according to the current adapted motor and will be effective only after power down.
 - c. After power on again, check several key parameters (See Table 8.2 below) of torque control and confirm that they are correct; the upper computer can send out an enable signal (or internal enable), and send out an analog value signal after the green lamp (**RUN**) is on and after automatic zeroing. Observe the dynamic effect of the motor, appropriately modify the gain and adjust the zero drift value.

PA--4	Control mode	→	Set to 6
PA--20	Driver disablement ineffective	→	Factory value=1
PA-40	Acceleration time constant	→	Set as required
PA-41	Deceleration time constant	→	Set as required
PA-43	Analog speed command gain	→	Set as required
PA-45	Analog speed zero drift compensation	→	Set as required

Table 8.3 Adjustment of Key Parameters of Torque Control

Dynamic Electronic Application

- Mainly used for application of position control.
- Dynamic electronic application

Dynamic electronic application refers to dynamically switching the electronic gear proportion via the make-and-break of the input terminal during the operation of the servo driver.

- It is mainly reflected on the limit of the maximum output frequency of the upper computer. When the proportion value of the electronic gear is very small, pulse resolution is high and the maximum speed can not be reached. However, in order to reach the maximum speed, the proportion value of the electronic gear of the upper computer is very great at this time. Low position resolution can affect transmission precision. (May appear system two microns instructions, system to send a pulse). In order to improve speed and transmission precision, multiple electronic gears with different gear ratios are added for switching so as to achieve better effect.
- Example: In the application of CNC machines, set the first electronic gear ratio —1/1 || —PA12/PA13 || , the second electronic gear ratio —10/1 || —PA52/PA13 || .

.....

```
G91 G01 X 10 F100 // The first electronic gear ratio is 1:1, it is 10 mm.
M 16 // PLC for Code M of the NC machine outputs a point to make INH have a signal.
G91 G01 X10 F100 // The second electronic gear ratio is 10:1, it is 100 mm.
M17 //数控机床 M 代码 PLC 关闭 INH 信号
M17 // PLC for Code M of the NC machine closes the INH signal.
M30 // Program ends.
```

PA--4		→	Set to zero
		→	
	Electronic gear numerator	→	1
		→	1
		→	1

Table 8.4 Adjustment of Parameters of Electronic Gear Ratios

Debugging of Typical Problems

I. (Run) the enable green lamp fails to be on.

- a. Check whether the voltages of three phases R, S and T are normal.
- b. Check whether the +24V for Pin 18 of CN1 interface is correct.
- c. Check whether Pin 10 of CN1 interface is connected with 0V.
- d. If the above all are normal and the green lamp still fails to be on, try again by using the internal enable PA53=0001.

II. Alarms—Err—9,Err—15,Err—30,Err—31,Err—32 || appears.

A photoelectric encoder is a very typical fragile, sensitive component, so it should be protected in every aspect.

- a. The above alarms indicate that the encoder or the wiring of the encoder is abnormal.
- b. Check whether both ends of the shielding layer are well grounded.
- c. Check that whether a too long wire will lead to attenuation to 5V power supply of the encoder.
- d. The photoelectric encoder may be damaged due to interference. Check whether there is a strong magnetic/heavy current circuit. If yes, isolate the circuit as much as possible.

III. The servo motor jitters.

- a. Confirm whether the load and inertia of the servo motor is within the permissible range of the motor.
- b. Adjust Parameters PA-5, PA-6, PA-7, PA-8, PA-9, PA-10, and PA-11.
- c. Add or reduce parameters according to the jitter conditions when the motor is running with high speed and low speed.

IV. The servo motor gives out noise.

- a. Confirm whether the load and inertia of the servo motor is within the permissible range of the motor.
- b. Adjust Parameters PA-5, PA-6, PA-7, PA-8, PA-9, PA-10, and PA-11.
- c. Add or reduce parameters according to the noise given out by the motor when the motor is running with high speed and low speed and stops.

V. Setting of electronic gear ratio

Take the NC machine as an example:

- a. The servo motor is directly connected with the lead screw (The lead screw rotates for one revolution when the motor rotates one revolution).
 - If the numerical control system programming is 10 mm, then sent out 10000 pulse
 - The photoelectric encoder has 2500 wires.
 - The pitch of the lead screw is 6mm.

PA12/PA13:

$$\begin{aligned} &= (\text{command value mm}) * (\text{the number of wires of the encoder}) * (4 \text{ quadruple} \\ &\quad \text{frequency}) / (\text{pitch}) * (\text{the number of pulses}) \\ &= 10 * 2500 * 4 / 6 * 10000 \\ &= 5/3 \end{aligned}$$

viz. PA12=5, PA13=3.

b. There is a reducer between the servo motor and the lead screw (The lead screw rotates for 2 revolutions when the motor for 5 revolutions).

- If the numerical control system programming is 10 mm, then sent out 10000 pulse
- The photoelectric encoder has 2500 wires.
- The pitch of the lead screw is 6mm.

PA12/PA13:

$$\begin{aligned} &= (\text{command value mm}) * (\text{the number of wires of the encoder}) * (4 \text{ quadruple} \\ &\quad \text{frequency}) * (\text{the revolution number of the motor}) / (\text{pitch}) * (\text{the number of pulses}) * (\text{the revolution} \\ &\quad \text{number of the lead screw}) \\ &= 10 * 2500 * 4 * 5 / 6 * 10000 * 2 \\ &= 25/6 \end{aligned}$$

Viz. PA12=25, PA13=6.

Chapter IX Servo Motor

Definition and Wiring of the Servo Motor Plug

I. Power Socket (with 4 prongs)

Winding lead	U	V	W	
Socket No.	2	3	4	1

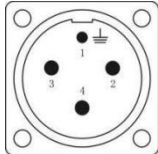

U, V and W are the lead ends of the winding coil of the servo motor. A round plug is dedicated for the motor with Seat 80.

II. Socket for Feedback Elements

- Socket (with 15 prongs) for standard incremental encoder (F)

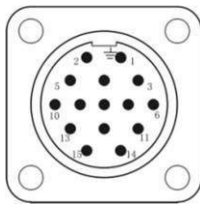

Signal	+5V	0V	A+	A-	B+	B-	Z+	Z-	U+	U-	V+	V-	W+	W-	
Socket No.	2	3	4	7	5	8	6	9	10	13	11	14	12	15	1

A+, B+, Z+, A-, B-, Z-, U+, U-, V+, V-, W+, and W- signals are the output signals of incremental encoder.

- Socket (with 9 prongs) for wire saving incremental encoder (F1):

Signal	+5V	0V	A+	A-	B+	B-	Z+	Z-	
Socket No.	2	3	4	7	5	8	6	9	1

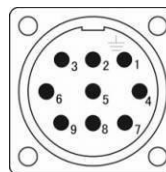

A+, B+, Z+, A-, B-, and Z- signals (composite signals) are the output signals of the wire saving incremental encoder.

A round plug is dedicated for the motor with Seat 80.

- Socket (with 7 prongs) for Bus-type encoder (M):

Signal	+5V	0V	SD+	SD-	E+	E-	
--------	-----	----	-----	-----	----	----	--

Socket No.	7	5	6	4	3	2	1
------------	---	---	---	---	---	---	---

SD+ and SD- are data output signals; E+ and E- are battery leads.

●Socket (with 7 prongs) for rotatable transformer (R)

Signal	R1	R2	S1	S3	S2	S4	
Socket No.	2	3	4	5	6	7	1

R1-R2 are primary signals, S1-S3 and S2-S4 are secondary signals.

III. Socket for Safe Brake (Band-type Brake):

Power supply	VDC(direct current power supply) without requirements on polarity access.		
Socket No.	1	2	3

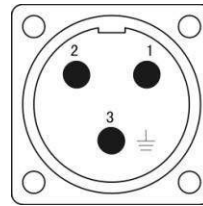

Safe brake parameters allocated for Seat 110

Working pressure: 24VDC (-15%~+10%), working current: $\leq 0.6A$, braking torque: $\geq 8Nm$

Safe brake parameters allocated for Seat 130

Working pressure: 24VDC (-15%~+10%), working current: $\leq 0.6A$, braking torque: $\geq 12Nm$

Safe brake parameters allocated for Seat 150

Working pressure: 100VDC (-15%~+10%), working current: $\leq 0.4A$, braking torque: $\geq 30Nm$

Description of Model Selection of Servo Motors

● Parameter characteristics

Seat (mm): 80, 110, 130, 150

Rated torque (Nm): 1.3-27

Rated speed (rpm): 1500,2000,2500,3000

Rated power (kW): 0.4-5.5

Standard matching feedback elements:
incremental encoder (2500C/T)

Safe brake: matching

Insulation level: B

Protection level: closed self-cooling IP65

Number of pole-pairs: 4

Installment mode: flange plate

Ambient temperature: 0-55⁰C

Ambient humidity: < 90% (without condensation)

Excitation mode: permanent magnet

Working voltage of adaptive driver (VAC): 220

●Description of type codes of LB series servo motors:

110 ST - M 020 30 L F B Z
(1) (2) (3) (4) (5) (6) (7) (8) (9)

(1) Seat No.

(2) AC Permanent magnet synchronous servo motor

(3) Type of feedback element: photoelectric encoder

(4) Rated torque: three figures $\times 0.1Nm$

(5) Rated speed: two figures $\times 100rpm$

(6) Working voltage of the driver (VAC): 220

- (7) Standard matching: F-incremental encoder (2500 C/T), F1- wire saving incremental encoder (2500C/T).
- (8) Medium inertia
- (9) A safe brake has been installed.

Dimensions and Type Selection Parameters of Servo Motors

• Seat 80

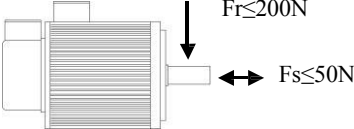
Type	80ST-M01330LF1B	80ST-M02430LF1B	80ST-M03330LF1B
Power	0.4 kW	0.75 kW	1.0 kW
Rated torque	1.3 Nm	2.4 Nm	3.3 Nm
Rated speed	3000 rpm	3000 rpm	3000 rpm
Rated current	2.6 A	4.2 A	4.2 A
Rotor inertia	$0.74 \times 10^{-4} \text{ Kg m}^2$	$1.2 \times 10^{-4} \text{ Kg m}^2$	$1.58 \times 10^{-4} \text{ Kg m}^2$
Maximum current	7.8 A	12.6 A	12.6 A
Maximum torque	3.9 Nm	7.2 Nm	9.9 Nm
Maximum radial and axial forces			

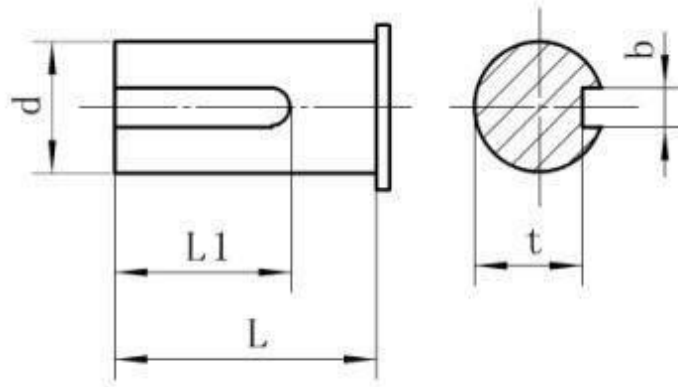

Seat 80:

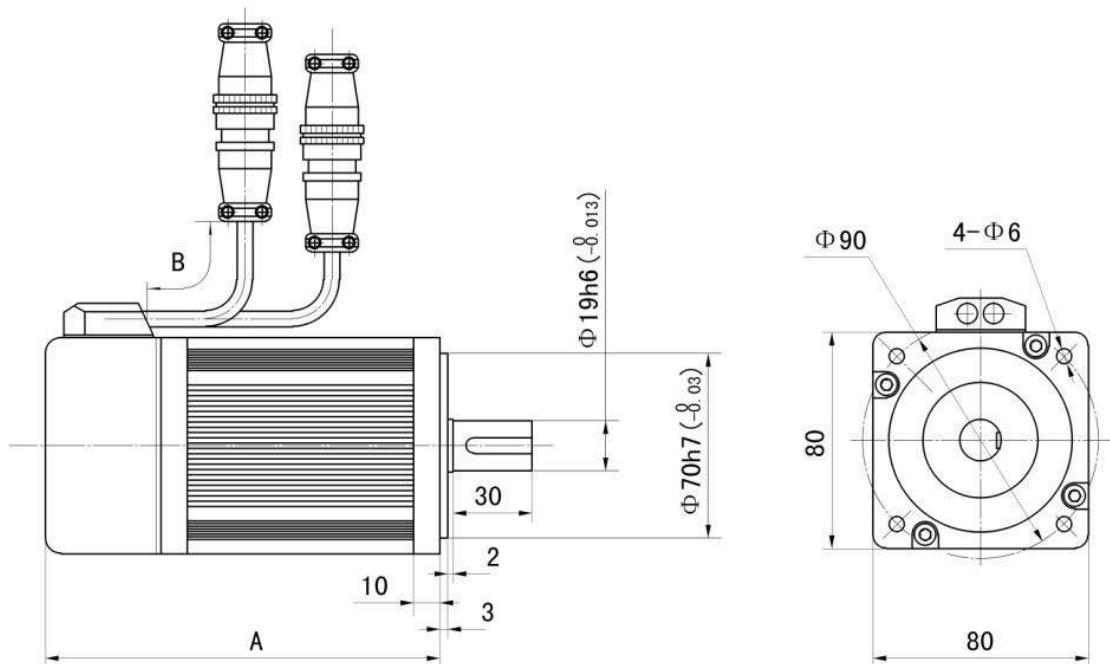

yp	A	B	L	L1	d	b	t
0S	1	5	3		Φ1	6	15.
0S	1	5	3		Φ1	6	15.
0S	1	5	3		Φ1	6	15.

-0.013 -0.03 -0.1
 -0.013 -0.03 -0.1
 -0.013 -0.03 -0.1

• Seat 11

Type	110ST-M020 30LFB	110ST-M04030 LFB	110ST-M05030 LFB	110ST-M06020 LFB	110ST-M06030 LFB
Power	0.6 kW	1.2 kW	1.5 kW	1.2 kW	1.6 kW
Rated torque	2.0 Nm	4.0 Nm	5.0 Nm	6.0 Nm	6.0 Nm
Rated speed	3000 rpm	3000 rpm	3000 rpm	2000 rpm	3000 rpm
Rated current	4.0 A	5.0 A	6.0 A	6.0 A	8.0 A
Rotor inertia	0.425×10^{-3} Kgm ² (0.489×10^{-3} Kgm ²)	0.828×10^{-3} Kgm ² (0.892×10^{-3} Kgm ²)	0.915×10^{-3} Kgm ² (0.979×10^{-3} Kgm ²)	1.111×10^{-3} Kgm ² (1.175×10^{-3} Kgm ²)	1.111×10^{-3} Kgm ² (1.175×10^{-3} Kgm ²)
Maximum current	12.0 A	15.0 A	18.0 A	18.0 A	24.0 A
Maximum torque	6.0 Nm	12.0 Nm	15.0 Nm	18.0 Nm	18.0 Nm
Maximum radial and axial forces					

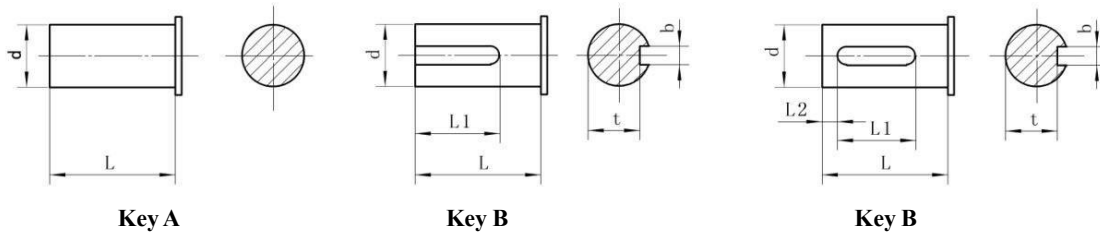

Seat 110:

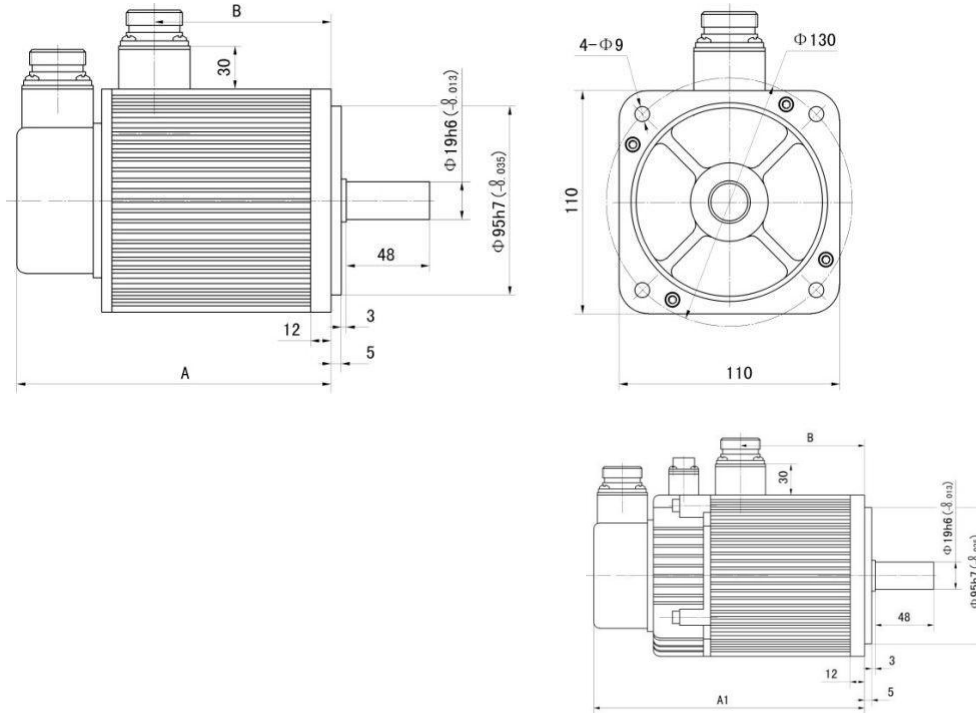

yp	A (m)	A1 (m)	B (m)	L (m)	L1 (m)	L2 (m)	d (m)	b (m)	t (m)
10S	1	2	76	4	40	3	Φ1 ₀	6 ₀	15 ₀
10S	1	2	1	4	40	3	Φ1 ₀	6 ₀	15 ₀
10S	2	2	1	4	40	3	Φ1 ₀	6 ₀	15 ₀
10S	2	2	1	4	40	3	Φ1 ₀	6 ₀	15 ₀
10S	1	5	3	8			Φ1 ₉	6 ₀	15 ₅

-0.013	-0.03	-0.1
-0.013	-0.03	-0.1
-0.013	-0.03	-0.1
-0.013	-0.03	-0.1

• Seat 130

Type	130ST-M04025LFB	130ST-M05020LFB	130ST-M05025LFB	130ST-M06025LFB
Power	1.0 kW	1.0 kW	1.3 kW	1.5 kW
Rated torque	4.0 Nm	5.0 Nm	5.0 Nm	6.0 Nm
Rated speed	2500 rpm	2000 rpm	2500 rpm	2500 rpm
Rated current	4.0 A	5.0 A	5.0 A	6.0 A
Rotor inertia	1.101×10 ⁻³ Kgm ²	1.333×10 ⁻³ Kgm ²	1.333×10 ⁻³ Kgm ²	1.544×10 ⁻³ Kgm ²

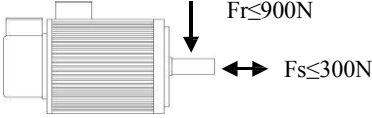
	$(1.268 \times 10^{-3} \text{ Kgm}^2)$	$(1.50 \times 10^{-3} \text{ Kgm}^2)$	$(1.50 \times 10^{-3} \text{ Kgm}^2)$	$(1.711 \times 10^{-3} \text{ Kgm}^2)$
Maximum current	12.0 A	15.0 A	15.0 A	18.0 A
Maximum torque	12.0 Nm	15.0 Nm	15.0 Nm	18.0 Nm
Maximum radial and axial forces				

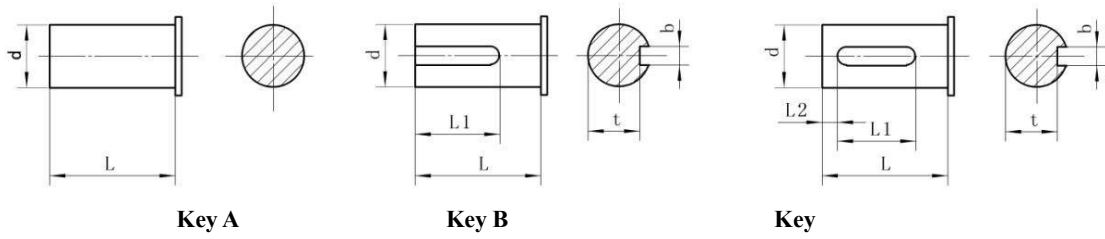

Seat 130:

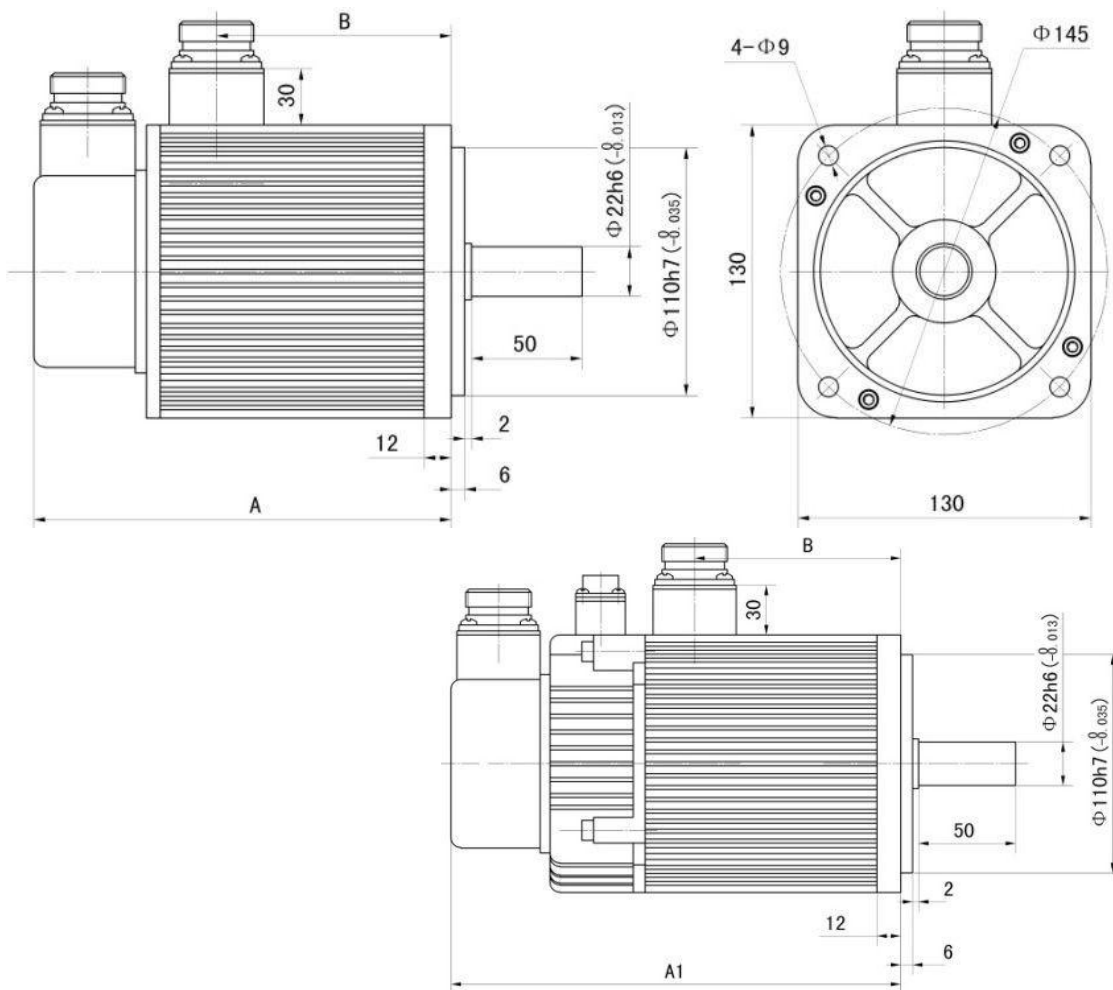

yp	A (m)	A1 (m)	B (m)	L (m)	L1 (m)	L2 (m)	d (mm)	b (mm)	t (mm)			
130	16	20	8	50	4	5	$\Phi 22^0$	6 ⁰	18.5 ⁰	-0.013	-0.03	-0.1
130 T-	17	21	8	50	4	5	$\Phi 22^0$	6 ⁰	18.5 ⁰	-0.013	-0.03	-0.1
130 ST-	18	22	9	50	4	5	$\Phi 2^0$	6 ⁰	18. ⁰	-0.013	-0.03	-0.1

• Seat 130

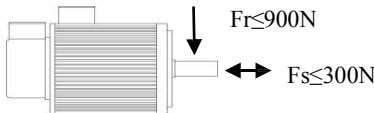
Type	130ST-M07720LFB	130ST-M07725LFB	130ST-M07730LFB	130ST-M10015LFB
Power	1.6 kW	2.0 kW	2.4 kW	1.5 kW
Rated torque	7.7 Nm	7.7 Nm	7.7 Nm	10Nm
Rated speed	2000 rpm	2500 rpm	3000 rpm	1500 rpm
Rated current	6.0 A	7.5	9.0	6.0
Rotor inertia	$2.017 \times 10^{-3} \text{ Kg m}^2$ ($2.184 \times 10^{-3} \text{ Kg m}^2$)	$2.017 \times 10^{-3} \text{ Kg m}^2$ ($2.184 \times 10^{-3} \text{ Kg m}^2$)	$2.017 \times 10^{-3} \text{ Kg m}^2$ ($2.184 \times 10^{-3} \text{ Kg m}^2$)	$2.595 \times 10^{-3} \text{ Kg m}^2$ ($2.762 \times 10^{-3} \text{ Kg m}^2$)
Maximum current	18.0 A	20.7 A	27.0 A	18.0 A
Maximum torque	23.1Nm	23.1 Nm	23.1 Nm	30.0 Nm
Maximum radial and axial forces				

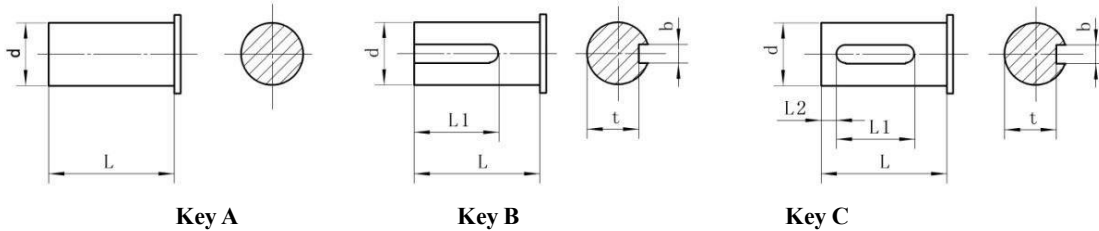

Seat 130:

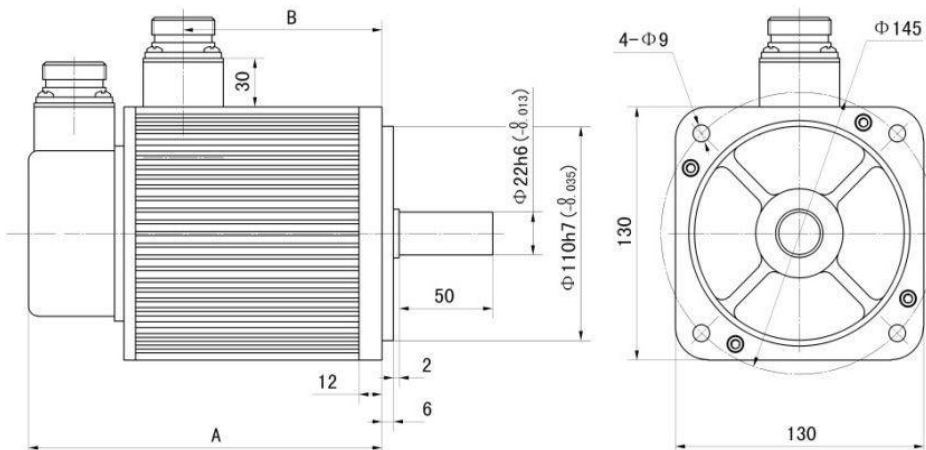

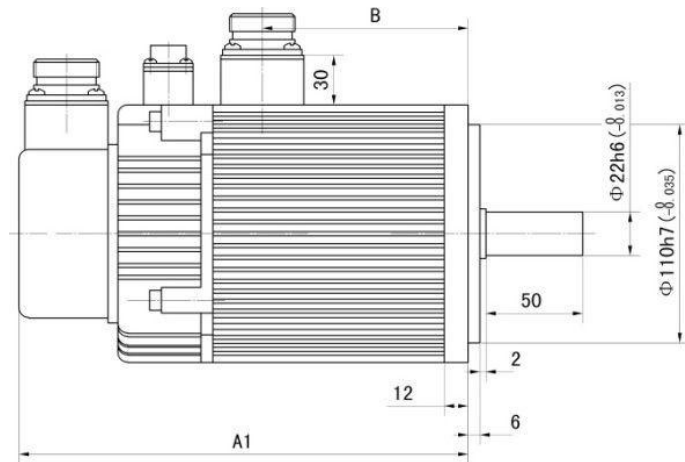

yp	A	A1	B	L	L1	L2	d (mm)	b (mm)	t (mm)			
130 ST-												
130 ST-	19.5	23.7	11.2	5.0	40	5	Φ22 ⁰	6 ⁰	18.5 ⁰	-0.013	-0.03	-0.1
130 ST-												
130	21	26	13	5	40	5	Φ2 ⁰	6 ⁰	18. ⁰	-0.013	-0.03	-0.1

• Seat 130

Type	130ST-M10025LFB	130ST-M15015LFB	130ST-M15025LFB
Power	2.6 Kw	2.3 Kw	3.9 Kw
Rated torque	10.0 Nm	15.0 Nm	15.0 Nm
Rated speed	2500 rpm	1500 rpm	2500 rpm
Rated current	10.0 A	9.5 A	17.0 A
Rotor inertia	2.595×10 ⁻³ Kgm ² (2.762×10 ⁻³ Kgm ²)	4.32×10 ⁻³ Kgm ² (4.487×10 ⁻³ Kgm ²)	4.32×10 ⁻³ Kgm ² (4.487×10 ⁻³ Kgm ²)
Maximum current	30.0 A	28.5 A	51.0 A
Maximum torque	30.0 Nm	45.0 Nm	45.0 Nm

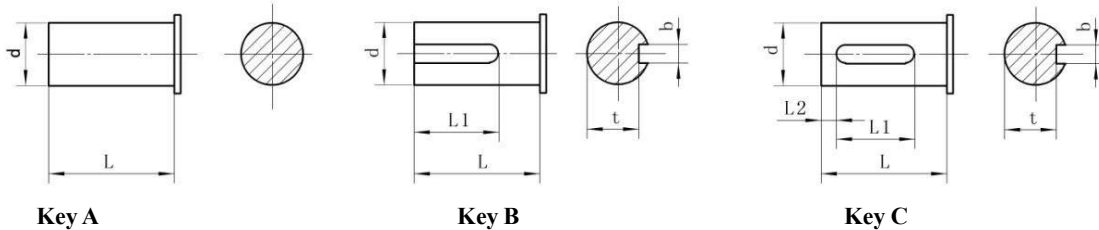

Seat 130:

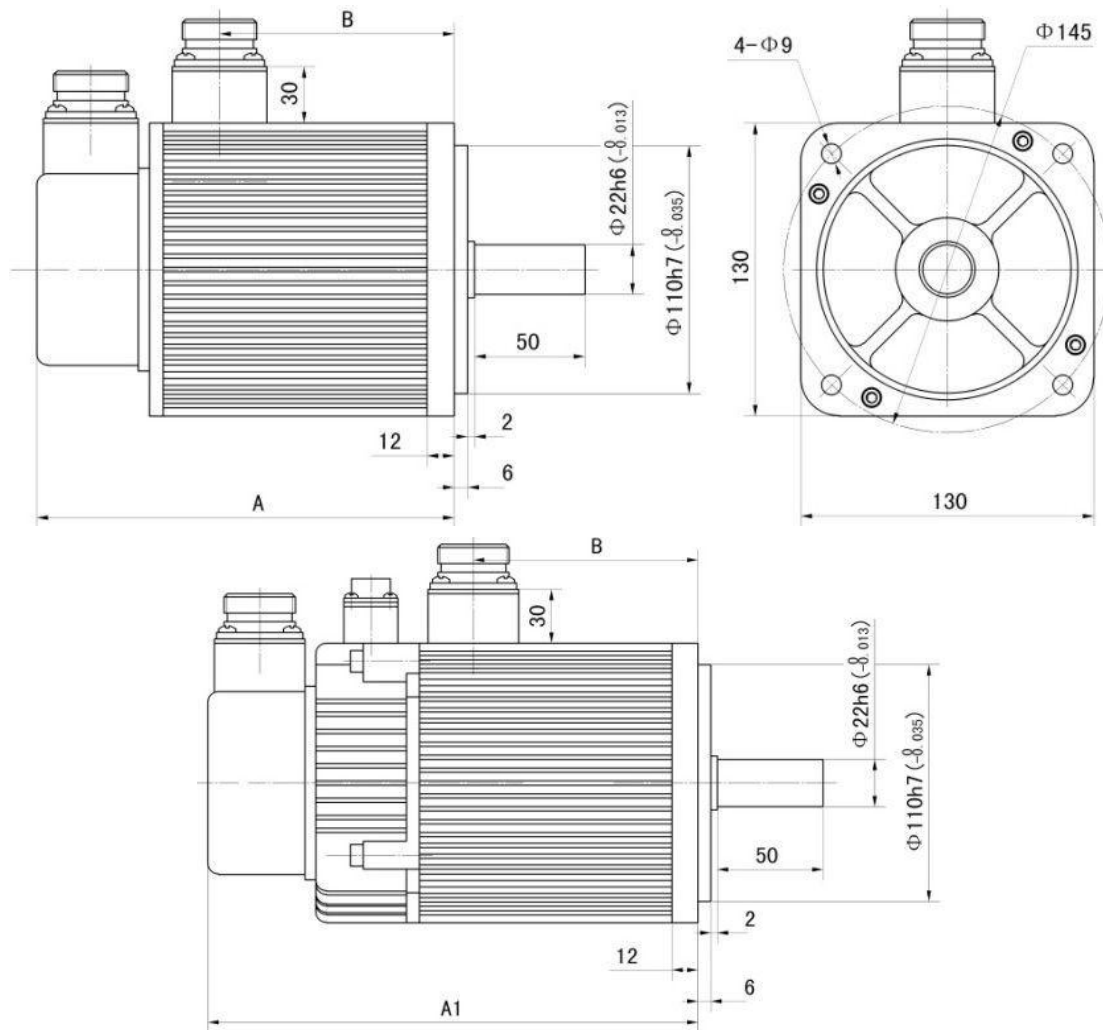

Type	A (mm)	A1 (mm)	B (mm)	L (mm)	L1 (mm)	L2 (mm)	d (mm)	b (mm)	t (mm)
130ST-M10025 LFB	219	261	136	50	40	5	$\Phi 22^0_{-0.013}$	$6^0_{-0.03}$	$18.5^0_{-0.1}$
130ST-M15015 LFB	267	309	184	50	40	5	$\Phi 22^0_{-0.013}$	$6^0_{-0.03}$	$18.5^0_{-0.1}$
130ST-M15025 LFB									

• Seat 150

Type	150ST-M15025LFB	150ST-M18020LFB
Power	3.8 Kw	3.6 Kw
Rated torque	15.0 Nm	18.0 Nm
Rated speed	2500 rpm	2000 rpm
Rated current	16.5 A	16.5 A

Rotor inertia	$6.15 \times 10^{-3} \text{ Kgm}^2$ ($6.75 \times 10^{-3} \text{ Kgm}^2$)	$6.33 \times 10^{-3} \text{ Kgm}^2$ ($6.93 \times 10^{-3} \text{ Kgm}^2$)
Maximum current	49.5 A	49.5 A
Maximum torque	45.0 Nm	54.0 Nm

• **Seat 150**

Type	150ST-M23020LFB	150ST-M27020LFB
Power	4.7 Kw	5.5 Kw
Rated torque	23.0 Nm	27.0 Nm
Rated speed	2000 rpm	2000 rpm
Rated current	20.5 A	20.5 A
Rotor inertia	$8.94 \times 10^{-3} \text{ Kgm}^2$ ($9.54 \times 10^{-3} \text{ Kgm}^2$)	$11.19 \times 10^{-3} \text{ Kgm}^2$ ($11.79 \times 10^{-3} \text{ Kgm}^2$)
Maximum current	61.5 A	61.5 A
Maximum torque	69.0 Nm	81.0 Nm

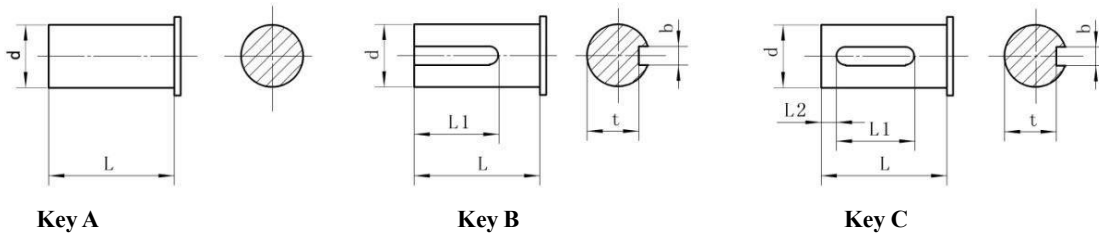

Seat 150

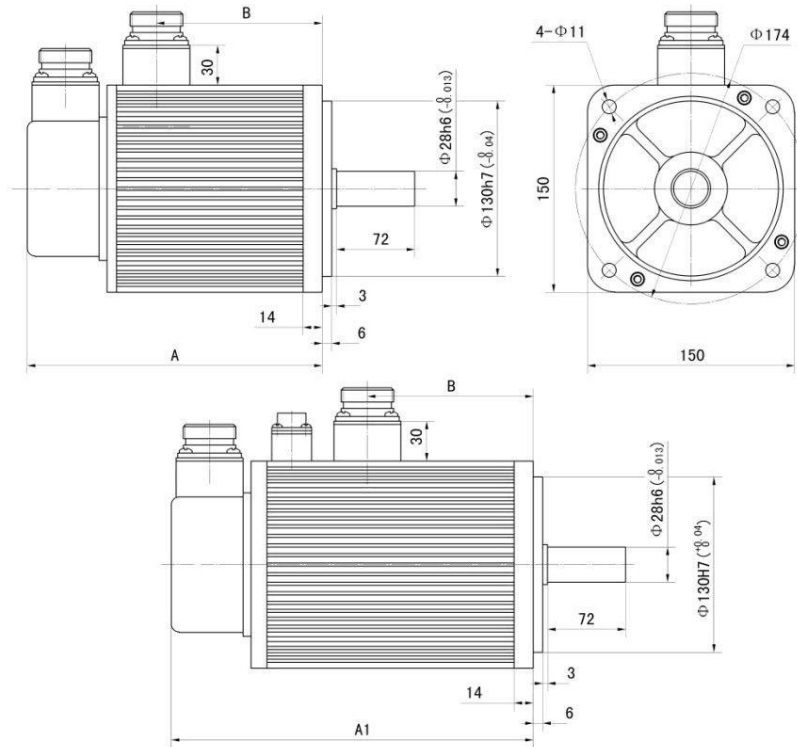

Type	A (mm)	A1 (mm)	L (mm)	L1 (mm)	L2 (mm)	d (mm)	b (mm)	t (mm)
150ST-M15025LFB	231	293	72	60(Key B) 55(Key C)	5	$\Phi 28 \begin{smallmatrix} 0 \\ -0.01 \end{smallmatrix}$	$8 \begin{smallmatrix} 0 \\ -0.03 \end{smallmatrix}$	$24 \begin{smallmatrix} 0 \\ -0.1 \end{smallmatrix}$
150ST-M18020LFB	250	312	72	60(Key B) 55(Key C)	5	$\Phi 28 \begin{smallmatrix} 0 \\ -0.01 \end{smallmatrix}$	$8 \begin{smallmatrix} 0 \\ -0.03 \end{smallmatrix}$	$24 \begin{smallmatrix} 0 \\ -0.1 \end{smallmatrix}$
150ST-M23020LFB	280	342	72	60(Key B) 55(Key C)	5	$\Phi 28 \begin{smallmatrix} 0 \\ -0.01 \end{smallmatrix}$	$8 \begin{smallmatrix} 0 \\ -0.03 \end{smallmatrix}$	$24 \begin{smallmatrix} 0 \\ -0.1 \end{smallmatrix}$
150ST-M27020LFB	306	368	72	60(Key B) 55(Key C)	5	$\Phi 28 \begin{smallmatrix} 0 \\ -0.01 \end{smallmatrix}$	$8 \begin{smallmatrix} 0 \\ -0.03 \end{smallmatrix}$	$24 \begin{smallmatrix} 0 \\ -0.1 \end{smallmatrix}$

●Curve diagram of torque and speed:

LB and HB series

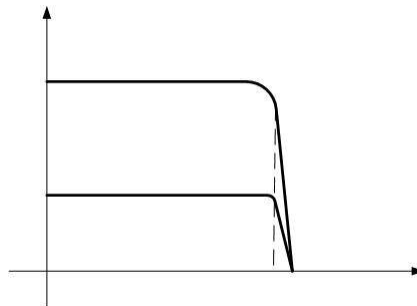

Mmax of LB and LBB series servo motor is equal to 3Mn; Mmax output status is the short time work of the servo motor. Please refer to the output capacity of the matching driver before use.

Appendix 1

Siemens NC system matched for MG -1000 Series Drivers

(To match Siemens 802S/801/802S)

1. Setting requirements for driver parameters

Parameter No.	Parameter Name	Unit	Parameter Range	Default
5	Speed ratio gain	Hz	50-2000	150
36	filter factor of command pulse signal	%	0-3	1

Note: ● When a Siemens NC system is matched for the driver, PA36 should be equal to 1 and PA37 to 0; otherwise repeated position precision will be affected.

- Where reset deviations are not uniform, appropriately increase Parameter 5 of the driver.
- Pins 36 and 9 of the CN1 interface port must be connected with the shielding layer and metal casing of the system; otherwise reset precision will be affected.

2. Setting requirements for Siemens system parameters

Parameter No.	Parameter Name	Required value
34040	Search for Z-pulse speed	500-2000

Appendix 2

Wiring Diagram for MG-1000B driver and Siemens 801/802S

与西门子 801、802S 接线图 Wiring diagram of the driver and Siemens and 801/802S

西门子 801 (×4 接口) Siemens 801(x4 interfaces)

西门子 801 (×20 接口) Siemens 801(x20 interfaces)

Z 轴 Z axis X 轴 X axis

西门子×4 插头金属壳 Siemens x 4 plug metal casing

注：驱动器端 36 和 9 脚一定要和屏蔽层和系统的金属壳相联。Note: Pins 36 and 9 at the driver side must be connected with the shielding layer and the metal casing of the system.

驱动器 Driver 屏蔽层 Shielding layer

编码器信号地 Encoder signal ground wire

外接+24V 电源 External connection to +24V power supply

外接 0V 电源 External connection to 0V power supply

PA-4 调整为 1、PA-22 调整为 1、PA-43 按需要调整 Adjust PA-4 to 1, PA-22 to 1 and adjust PA-43 as required

PA-40 调整为 1、PA-41 调整为 1。 Adjust PA-40 to 1 and PA-41 to 1.

西门子 802C 系统参数调整：西门子 802C 系统的参数 30130 要改为“1”。

Siemens 802C system parameter adjustment: Parameter 30130 of Siemens 802C system should be changed to 1 .

按以上接线图接好线后，先调整好以上参数，在系统上电，驱动器上电，打开驱动器使能，系统保持零速状态，调整驱动器 AU-Spd（模拟量速度零偏自动调整）。调整方法为：在驱动器的第一层菜单界面找到 AU，再按 enter 一次，显示 AU-Spd，再按住 enter 不放，并保持 3 秒，就会显示 FINISH（成功），最后保村参数即可。

After wiring as per the above the wiring diagram, first adjust the above parameters, electrify the system and the driver, open the driver enable, keep the system in zero speed state, and adjust the AU-Spd of the driver (automatic adjustment of speed bias of analog value). The adjustment method thereof: Find AU in the first menu interface of the driver and press enter once again to display AU-Spd. Then press down enter for 3 seconds and FINISH (success) will be displayed. Finally store the parameters.

Appendix 4

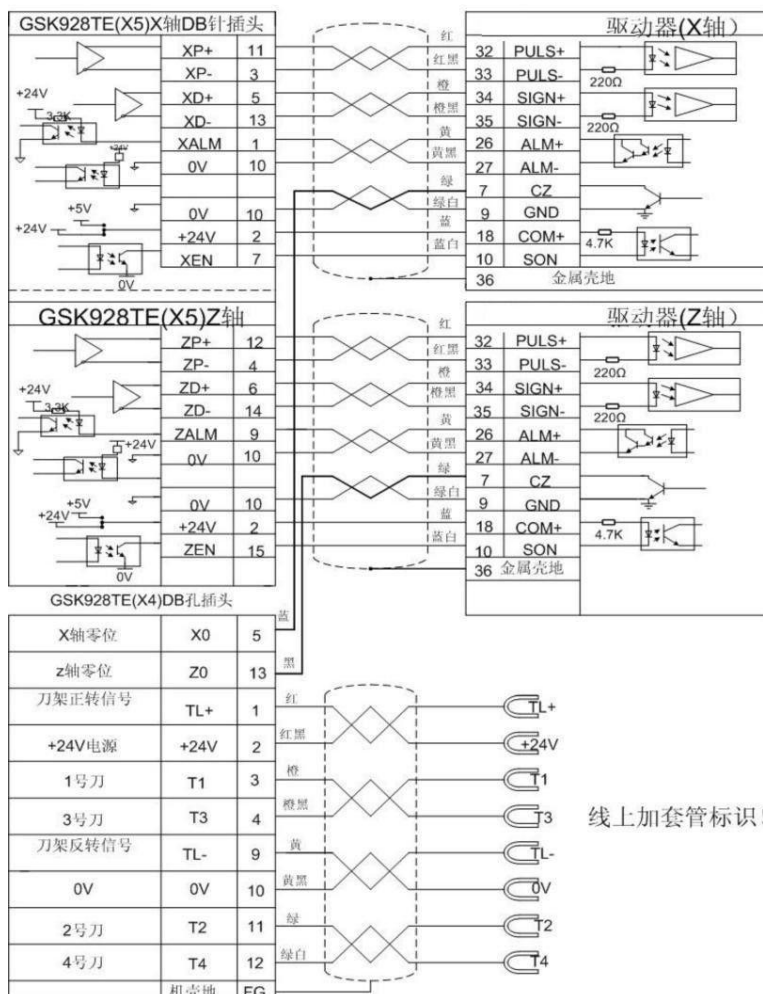

GSK928TE (×5) X 轴 DB 针插头 GSK928TE(x5) X axis DB pin plug

驱动器 (X 轴) Driver (X axis)

红 Red

红黑 Red & black 橙

黑 Orange & black

黄黑 Yellow & black

绿 Green

绿白 Green & white

蓝 Blue

蓝白 Blue & white

黑 Black

金属壳地 metal casing ground wire GSK928TE

(×5) Z 轴 GSK928TE (x5) Z axis

驱动器 (Z 轴) Driver (Z axis)

金属壳地 metal casing ground wire

GSK928TE (×4) DB孔插头 GSK928TE(x4) DB hole plug

X轴零位 X axis zero position

Z轴零位 Z axis zero position

刀架正转信号 Tool holder forward rotation signal

+24V电源 +24V power supply

1号刀 Tool 1

3号刀 Tool 3

刀架反转信号 Tool holder reverse rotation signal

2号刀 Tool 2

4号刀 Tool 4

机壳地 Driver housing ground wire

线上加套管标识! Marks for adding a bushing on a wire!

Appendix 5

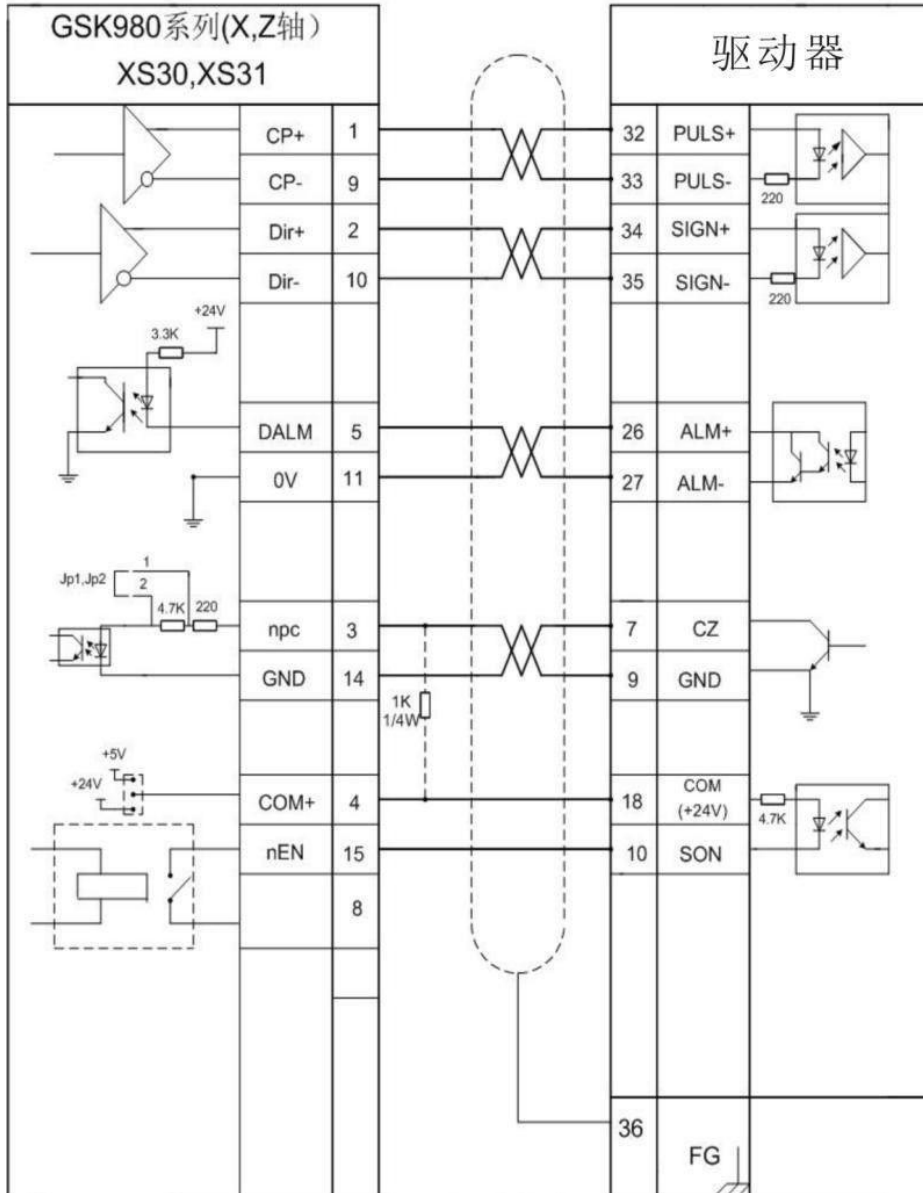

GSK980 系列 (X, Z 轴) GSK980 series (X axis and Z axis)

驱动器 Driver

Appendix 6

Wiring Diagram of MG-1000 Series of Drivers with KND NC System

注 1 Note 1

注 2 Note 1

数控系统侧 NC system side

驱动器侧 Driver side 信号 名

称 Signal Name 管脚

Pin

金属壳接地 Metal casing grounded

Appendix 7

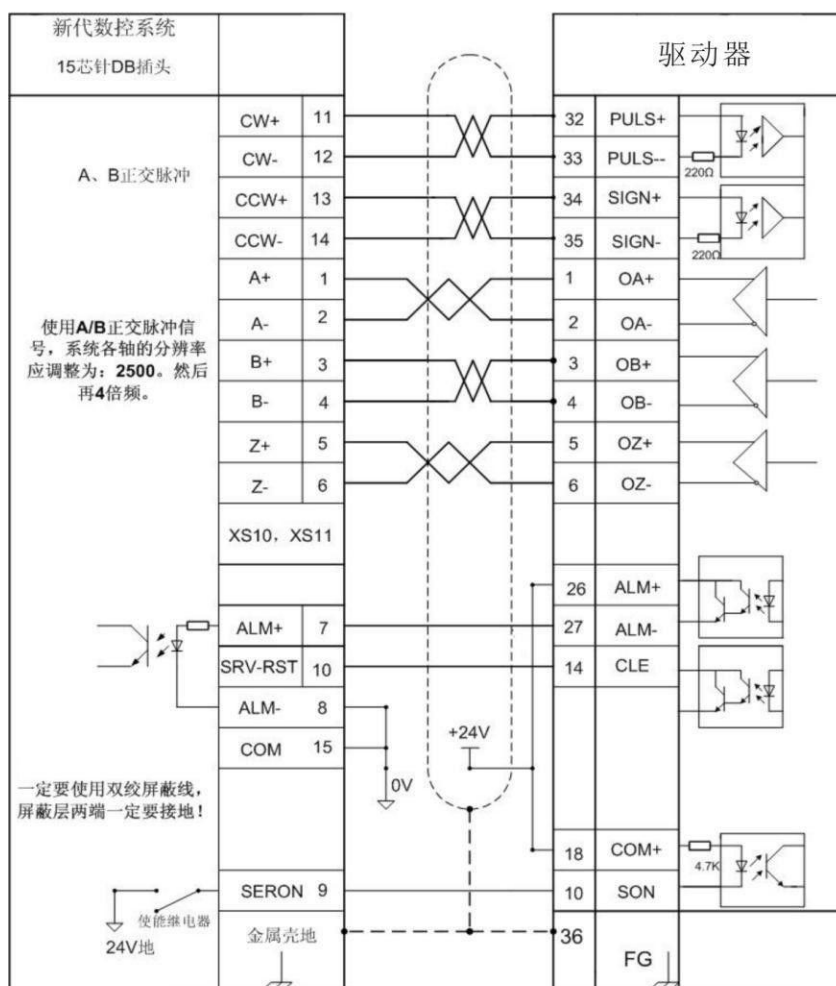

新代数控系统 SYNTEC NC system

15 芯针 DB 插头 15-core DB plug 驱

动器 Driver

A、B 正交脉冲 A&B orthogonal pulses

使用 A/B 正交脉冲信号，系统各轴的分辨率应调整为：2500，然后再 4 倍频

A/B orthogonal pulse signal should be used. The resolution of all axes of the system should be adjusted to 2500 and then quadruple frequency.

一定要使用双绞屏蔽线，屏蔽层两端一定要接地。

Twisted-pair shielding wire must be used. Both ends of the shielding layer must be grounded.

使能继电器 Enable relay

24V 地 24V ground wire

金属壳地 Metal casing ground wire

Appendix 8

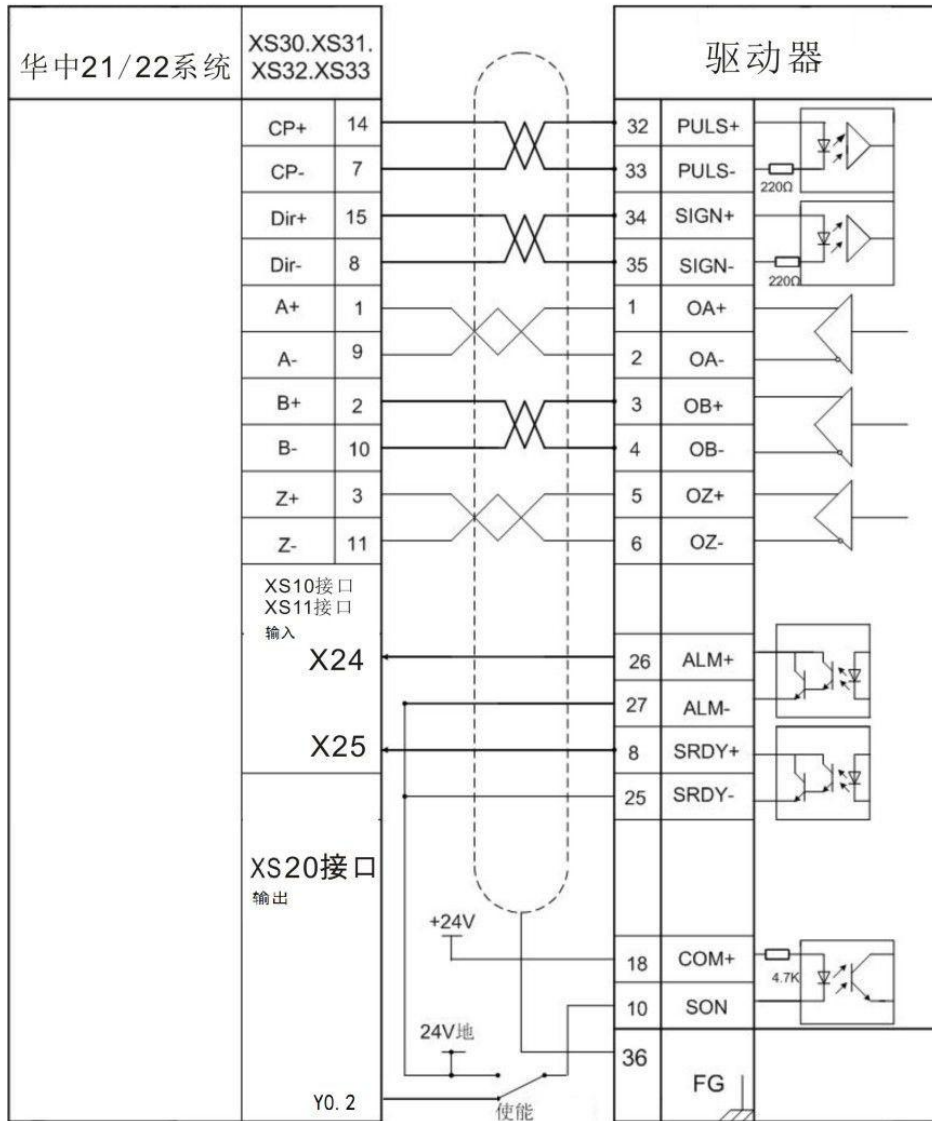

位置控制方式接线图

华中 21/22 系统 Huazhong 21/22 system

XS10 接口 XS10 interface

XS11 接口 XS11 interface

输入 Input

XS20 接口 XS20 interface

输出 Output

24V 地 24V ground wire

使能 Enable

驱动器 Driver

位置控制方式接线图 Wiring Diagram for Position Control Mode

Appendix 9

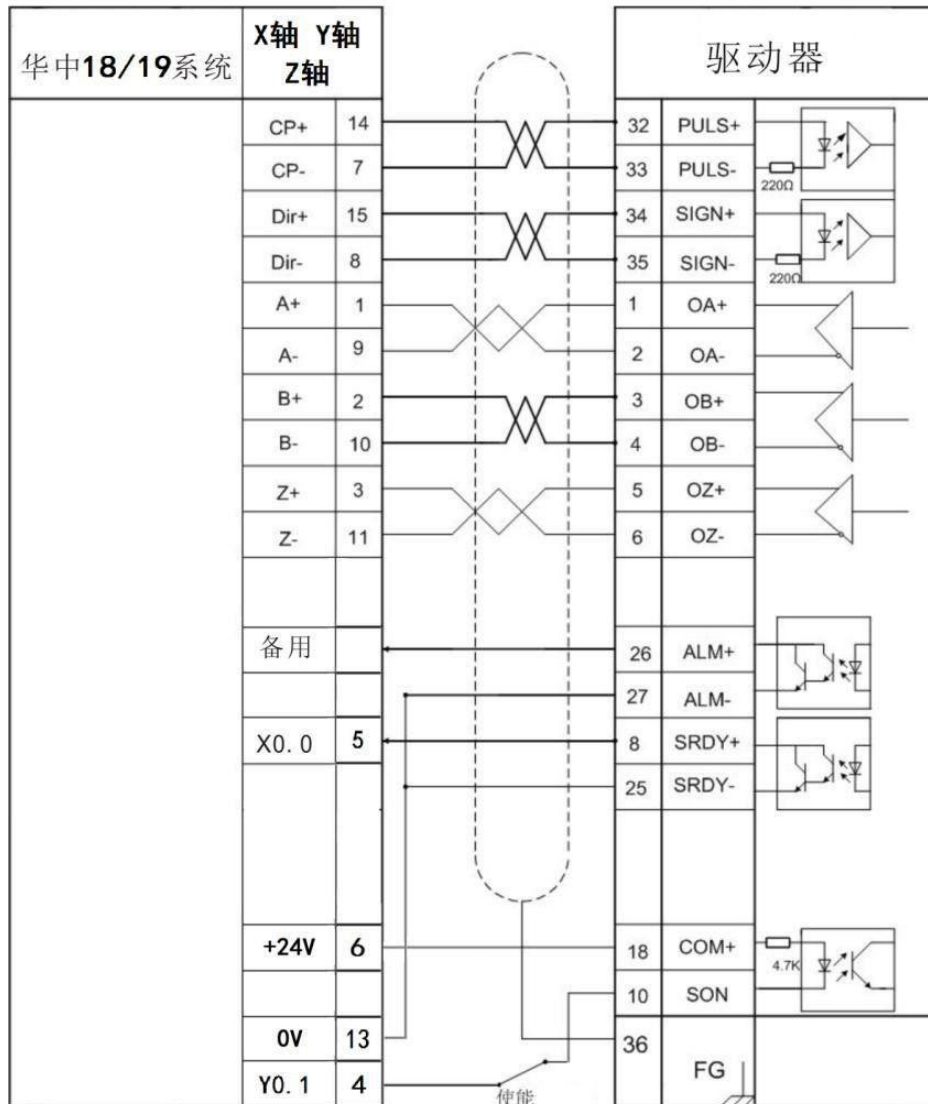

位置控制方式接线图

华中 18/19 系统 Huazhong 18/19 system

X 轴 X axis

Y 轴 Y axis

Z 轴 Z axis

驱动器 Driver

备用 Standby

使能 Enable

位置控制方式接线图 Wiring Diagram for Position Control Mode

Appendix 10

This product and the manual are only used for general industrial purposes. Where this product is used with equipment directly relative to life and safety, such as medical treatment, aviation, aerospace, and nuclear power, etc. Please contact the manufacturer.

This manual shall not be reprinted or copied in part or in whole without the permission of the company. This product is subject to change without further notice due to constant renovation.

